

Homologowane czujniki dodatkowe

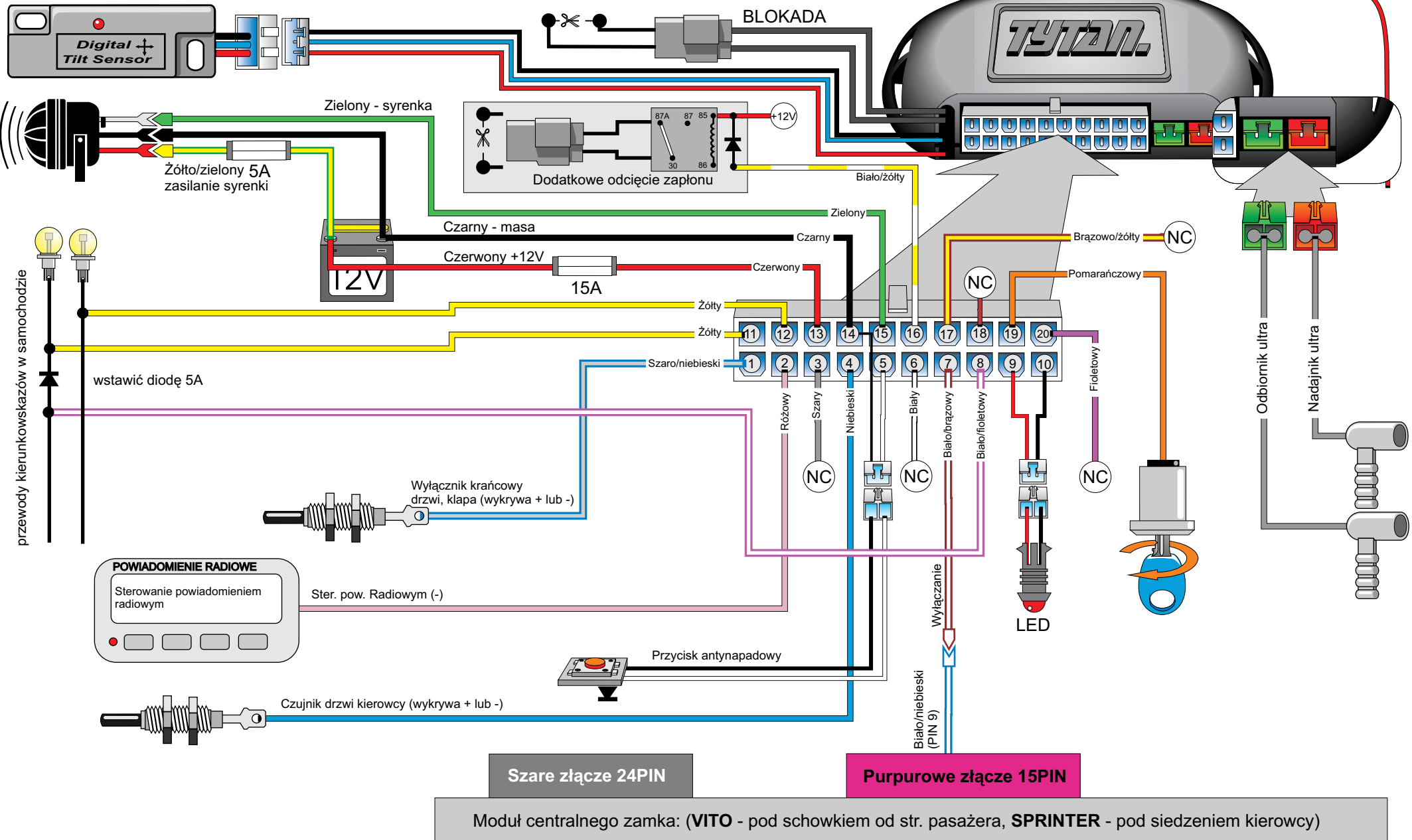

<p>Digital Systems sj Krzysztof Baluta & Jacek Szmelczyński 84-230 Rumia, ul. Sędzickiego 57 tel./fax (58) 671-43-48, 671-01-14</p>	<p>tytan Ds300 RS</p>	<p>Marka: MERCEDES</p>	<p>Model: Sprinter</p>	<p>Rok: 02 ></p>
	<p>Nr rys. 39p Rev. 00</p>	<p>Parametr: 1 Poziom: 13</p>	<p>Model: Vito (2 przyciski w pilocie)</p>	<p>Rok: 01 ></p>