



## CAR SECURITY

### SPECIFIC VEHICLE ALARM FITTING INSTRUCTIONS

REV. 00

www.cobra.it

MAKE

**PEUGEOT**

MOD.

**BOXER \***

YEAR.

**02** →

PETROL   
DIESEL

\* Models with original equipment keyless entry system.

#### ALARM/SIREN POSITION

Position the compact alarms and the sirens in the engine compartment, on the bracket located on the left of the shock absorber, driver's side.

#### CENTRAL UNIT POSITION

Position the modular systems and the modules under the dashboard, driver's side.

#### POWER SUPPLY

**+30:** connect to the 3 mm<sup>2</sup> GREY wire, located in the wiring harness coming out of the 2 way grey connector of the BSI central.  
**- 31:** connect directly to the car body.

#### IGNITION WIRE

**+15/54:** connect to the VIOLET wire, at the position nr.22, of the 26 way light blue connector of the BSI central.

#### DIRECTION INDICATORS

Connect to the wires at the positions nr. 14 and nr. 15 of the 16 way black connector of the BSI operating central.

#### ELECTRIC WINDOWS

##### Positive control signal

##### Front window, driver's side:

Give a positive pulse of 12s. to the wire at the position nr. 12, in the 16 way black connector, of the push buttons panel, inside the driver's side arm-rest.

##### Front window, passenger's side:

Cut the 2mm<sup>2</sup> GREY wire, at the position nr. 10, of the 16 way black connector, of the push buttons panel, inside the driver's side arm-rest.

##### Rear window, driver's side:

Cut the 2mm<sup>2</sup> VIOLET wire, at the position nr.7, of the 16 way black connector, of the push buttons panel, inside the driver's side arm-rest.

##### Rear window, passenger's side:

Cut the 2mm<sup>2</sup> GREY wire, at the position nr.6, of the 16 way black connector, of the push buttons panel, inside the driver's side arm-rest.

#### ACTIVAT./DEACTIVATION CONTROLS

##### Connections antitheft/vehicle

Refer to the **diagram nr. 168.**

#### IMMOBILISATION POINT

##### Fuel pump

Cut the WHITE wire MARKED n°122 located in the wiring harness behind the sill cover, driver's side.

#### STARTER

**+50:** Cut the control wire for the activation of the relay of the starter located in the wiring harness coming out of the connector of the ignition key.

#### BONNET SWITCH

Install an additional switch on the front headlamp support plate, driver's side.

#### DOORS SWITCH

Connect to the GREEN wire, at the position nr. 16, of the 26 way light blue connector, of the BSI operating central.

#### BOOT SWITCH

Connect to the wire nr. 319 directly in the wiring harness coming out of the boot lamp.



CAR SECURITY

SPECIFIC VEHICLE ALARM FITTING INSTRUCTIONS

REV. 00

www.cobra.it

FITTING DIAGRAM N°168

Diagram for the interfacing of art. 3800 on  
**PEUGEOT BOXER year 2002**

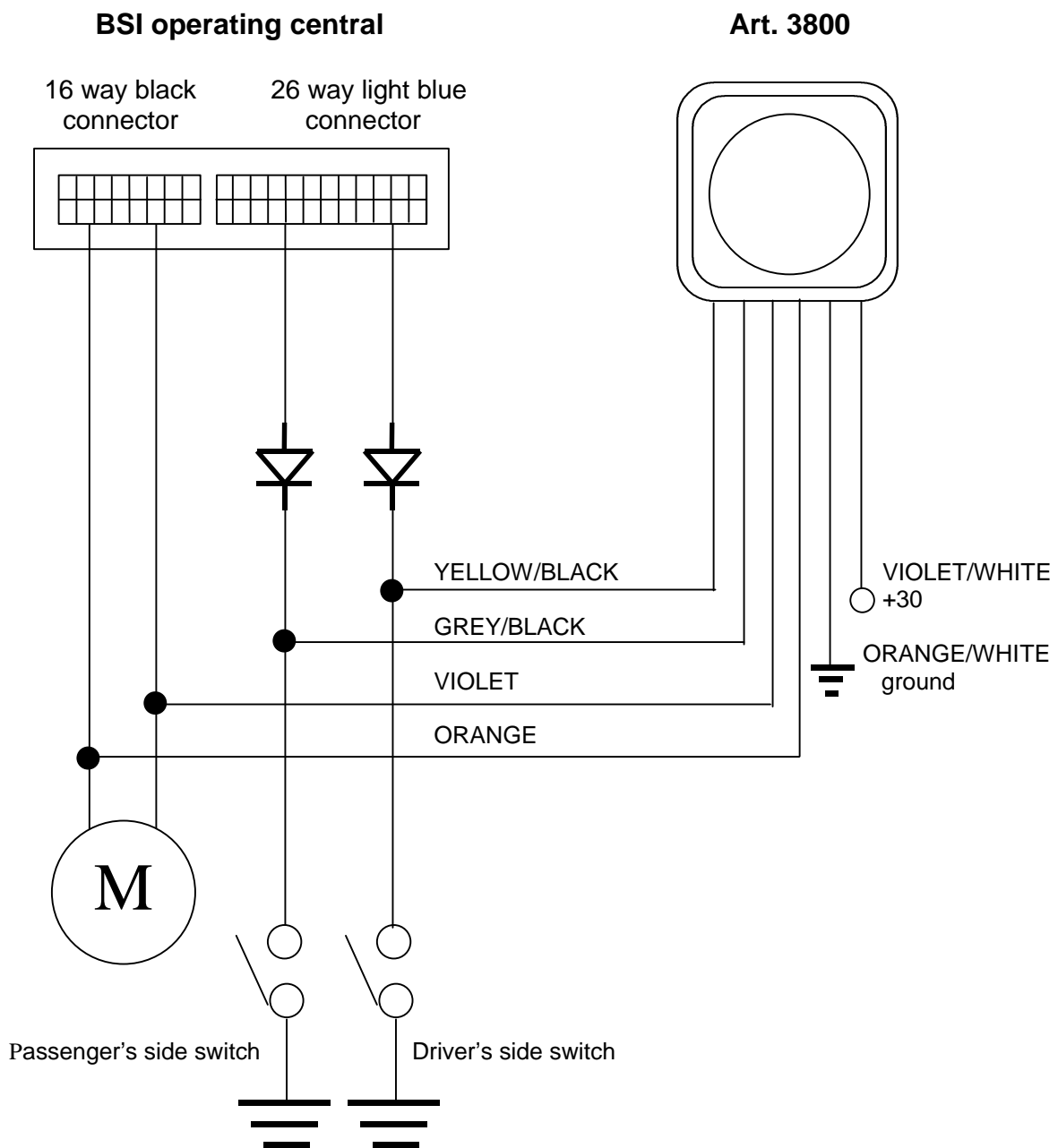

Note: This information is not binding, therefore it must be considered only an example for installation purposes that must be executed as per the instructions given on the product installation manual.