



CAR SECURITY

SPECIFIC VEHICLE ALARM FITTING INSTRUCTIONS

REV. 00

www.cobra.it

MAKE

PEUGEOT

MOD.

406*

YEAR.

01 →

PETROL
DIESEL

* Models with original equipment keyless entry system.

ALARM/SIREN POSITION

Position the compact alarms and the sirens in the engine compartment on the support located on the left of the shock absorber column, driver's side.

CENTRAL UNIT POSITION

Position the modular systems and the modules under the dashboard, driver's side.

POWER SUPPLY

+ **30**: connect to the 3 mm² GREY wire located in the wiring harness coming out of the 2 way grey connector of the BSI central unit.
- **31**: connect directly to the car body.

IGNITION WIRE

+ **15/54**: connect to the VIOLET wire at the position nr. 22 of the 26 way light blue connector of the BSI central unit.

DIRECTION INDICATORS

Connect to the wires at the positions nr. 14 and nr. 15 of the 16 way black connector of the BSI operating central.

ELECTRIC WINDOWS

Positive control signal

Front window, driver's side:

Give a 12s positive pulse to the wire located at the position nr.12 in the 16 way black connector of the push-button panel inside the driver's side armrest.

Front window, passenger's side:

cut the 2 mm² GREY wire located at the position nr. 10 of the 16 way black connector of the push-button panel inside the driver's side armrest.

Rear window, driver's side:

Cut the 2 mm² VIOLET wire located at the position nr. 7 of the 16 way black connector of the push-button panel inside the driver's side armrest.

Rear window, passenger's side:

cut the 2 mm² GREY wire at the position nr. 6 of the 16 way black connector of the push-button panel inside the driver's side armrest.

ACTIVAT./DEACTIVATION CONTROLS

Connections antithefts/vehicle

Refer to the **diagram nr. 89**.

IMMOBILISATION POINT

Gasoil pump

Cut the wire marked nr. 121 located at the position nr. 13 of the 23 way grey round connector placed in the upper part of the BSI operating central.

STARTER

+**50**: Cut the activation control wire of the relay of the starting motor located in the wiring harness coming out of the connector of the ignition key.

BONNET SWITCH

Install an additional switch on the headlamp support plate, driver's side.

DOORS SWITCH

Connect to the GREEN wire located at the position nr. 16 of the 26 way light blue connector of the BSI operating central.

BOOT SWITCH

Connect to the wire marked nr. 319 directly in the wiring harness coming out of the boot lamp.



CAR SECURITY

SPECIFIC VEHICLE ALARM FITTING INSTRUCTIONS

REV. 00

www.cobra.it

FITTING DIAGRAM N° 89

Diagram for the interfacing of art. 3800 on
PEUGEOT 406 – 406 coupè

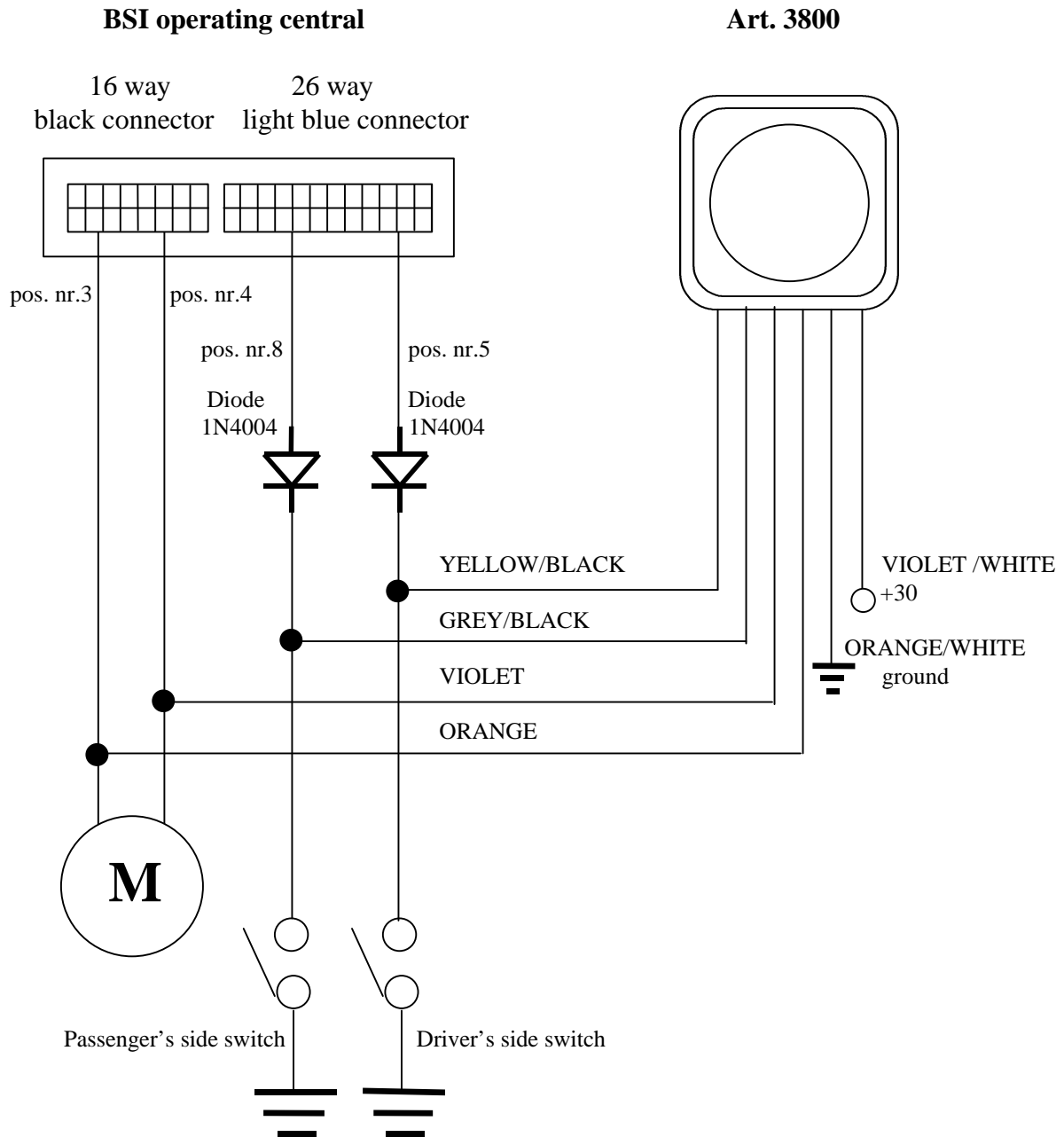

Note: This information is not binding, therefore it must be considered only an example for installation purposes that must be executed as per the instructions given on the product installation manual.

pe40601gbdtd.doc