



CAR SECURITY

SPECIFIC VEHICLE ALARM FITTING INSTRUCTIONS

REV. 00

www.cobra.it

MAKE

PEUGEOT

MOD.

206

YEAR.

02 →

PETROL
DIESEL

ALARM/SIREN POSITION

Position the compact alarms and the sirens on the wheelhouse, passenger's side.

CENTRAL UNIT POSITION

Position the modular systems and the modules under the dashboard.

POWER SUPPLY

+ 30: connect to the 3 mm² wire, at the position nr. 2, of the 2 way black connector coming out of the front part of the BSI operating central.
- 31: connect to the wire, at the position nr. 9 of the 16 way black connector coming out of the BSI operating central.

IGNITION WIRE

+ 15/54: connect to the wire at the position nr. 14 of the 16 way grey connector..

DIRECTION INDICATORS

Connect to the wires at the positions nr. 13 and nr. 14 of the 16 way black connector.

ELECTRIC WINDOWS

Positive control signal

Front window, driver's side:

Refer to the **diagram nr. 96.**

Front window, passenger's side:

Refer to the **diagram nr. 96.**

Rear window, driver's side:

Cut the GREY wire located at the position B 4 coming out of the original push-button panel.

Rear window, passenger's side:

Cut the GREY wire located at the position A1 coming out of the original push-button panel.

CENTRAL DOORS LOCKING

Door original motor direct signal

Cut the WHITE wire, at the position nr. 15 (unlock) and the GREY wire located at the position nr. 13 (lock) located in the wiring harness coming out of the 16 way grey connector. For the Bridge serie antithefts refer to the **diagram nr. 78**, for 3100 serie antithefts refer to the **diagram nr. 78A**.

IMMOBILISATION POINT

Gasoil pump

Cut the BROWN wire located in the wiring harness coming out of the inertial switch installed above the support of the shock absorber, driver's side.

STARTER

+ 50: Cut the BLUE wire located in the wiring harness coming out of the connector of the ignition key.

BONNET SWITCH

Install an additional switch on the front headlamp support plate, driver's side.

DOORS SWITCH

Connect to the wire, at the position nr. 32 of the green connector, inside the connection with white covering, in the fuse box.

Note: The lamp polarity is positive.

BOOT SWITCH

When the boot is provided with the lamp, connect directly to the negative control coming out of the same; as alternative, install an additional switch.



CAR SECURITY

SPECIFIC VEHICLE ALARM FITTING INSTRUCTIONS

REV. 00

www.cobra.it

FITTING DIAGRAM N° 78

Diagram for lock/unlock of the doors on
PEUGEOT 206 year 2002
(For Bridge serie antithefts)

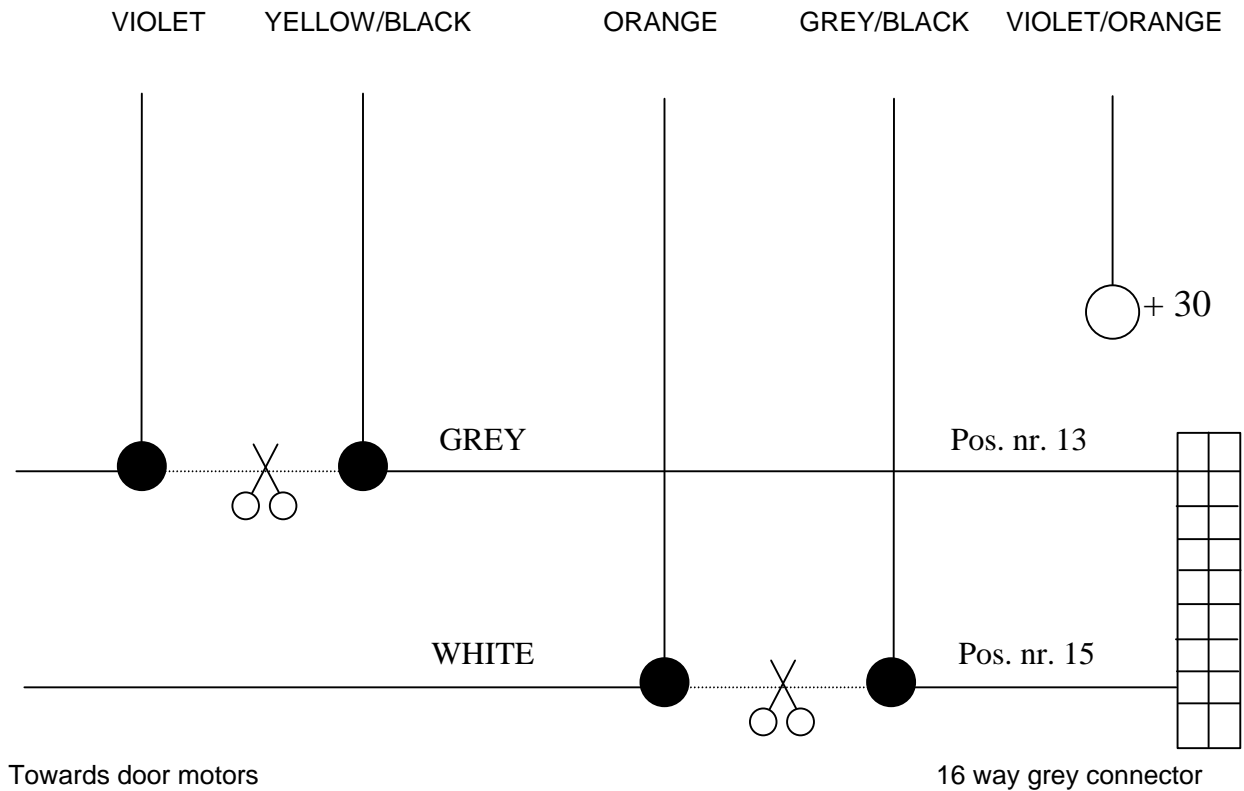



CAR SECURITY

SPECIFIC VEHICLE ALARM FITTING INSTRUCTIONS

REV. 00

www.cobra.it

FITTING DIAGRAM N° 78A

Diagram for lock/unlock of the doors on
PEUGEOT 206 year 2002
(For 3100 serie antithefts)

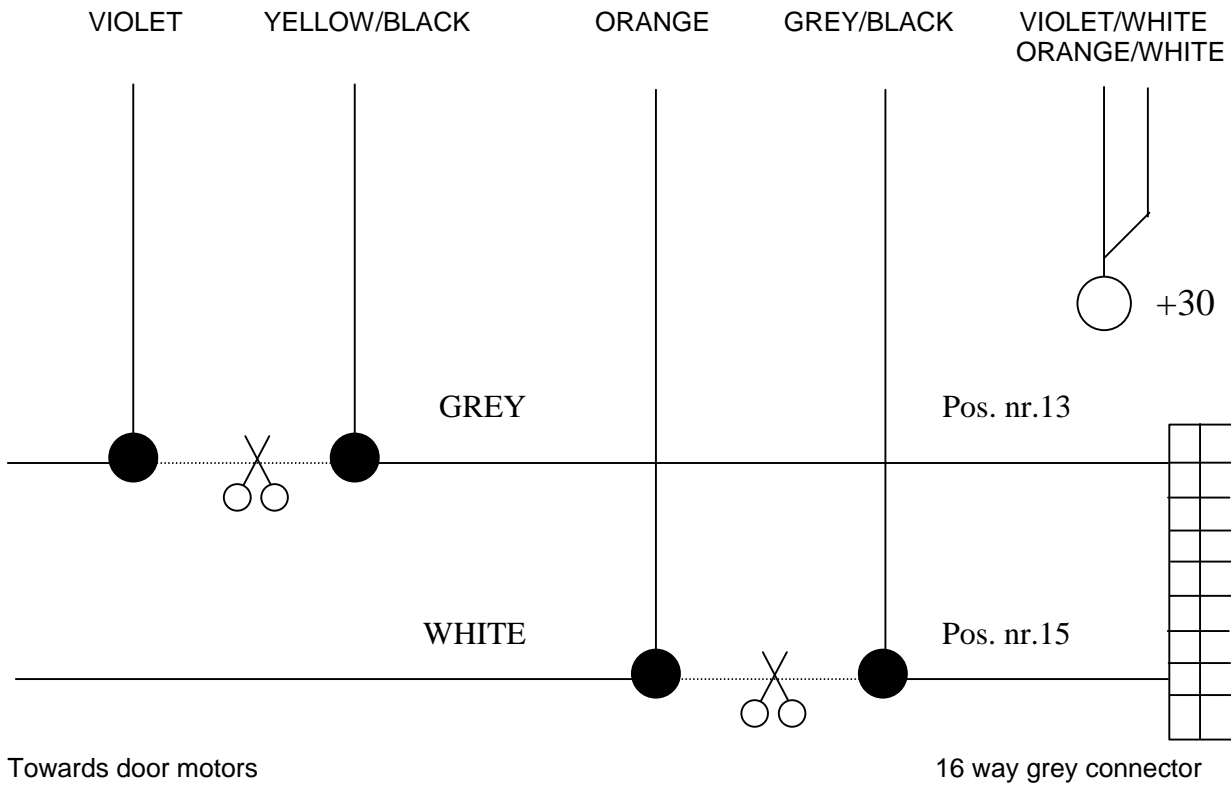



CAR SECURITY

SPECIFIC VEHICLE ALARM FITTING INSTRUCTIONS

REV. 00

www.cobra.it

FITTING DIAGRAM N° 96

Diagram for windows connection on
PEUGEOT 206 year 2002

Diagram for windows locking using the BROWN/WHITE wire of the autodriven Bridge serie antithefts.

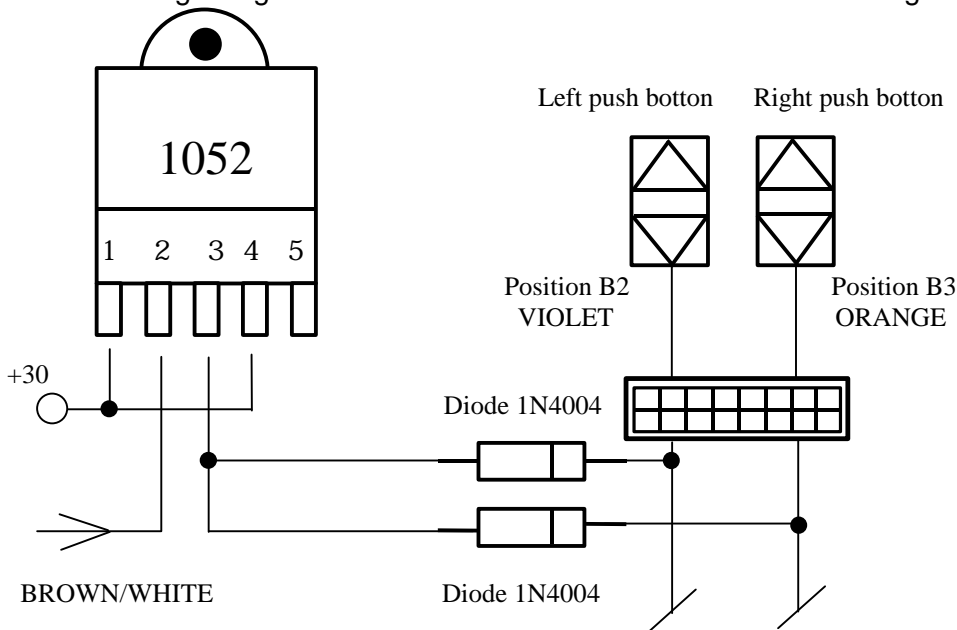

Diagram for windows locking using the BROWN wire of the no autodriven Bridge serie, 3100 and 3800 antithefts.

