



## CAR SECURITY

### SPECIFIC VEHICLE ALARM FITTING INSTRUCTIONS

REV. 00

www.cobra.it

MAKE

**PEUGEOT**

MOD.

**106\***

YEAR.

**01** →

PETROL   
DIESEL

\* Models with original equipment keyless entry system.

#### ALARM/SIREN POSITION

Position the compact alarms and the sirens in the engine compartment on the shock absorber support.

#### CENTRAL UNIT POSITION

Position the modular systems and the modules above the glove compartment, driver's side.

#### POWER SUPPLY

+ **30**: connect to the wire marked BH08A located at the position nr. 1 of the 9 way brown connector coming out of the central unit of the central locking.

- **31**: connect directly with a cable terminal to the car body. As alternative, connect directly to the negative pole of the battery.

#### IGNITION WIRE

+ **15/54**: connect to the wire marked 2194 located in the 2 way black connector coming out of the ignition key.

#### DIRECTION INDICATORS

Connect to the RED wire marked 2310 and to the GREEN wire marked 234 located respectively at the positions A4 and A2 placed in the connector coming out of the lights switch.

#### ELECTRIC WINDOWS

##### Positive control signal

##### Front window, driver's side:

cut the LIGHT BROWN wire located at the position nr. 1 of the connector coming out of the relevant control push botton.

##### Front window, passenger's side:

cut the LIGHT BROWN wire located at the position nr. 1 of the connector coming out of the relevant control push botton.

#### ACTIVAT./DEACTIVATION CONTROLS

##### Connections antithefts/vehicle

Refer to the **diagram nr. 93**.

#### IMMOBILISATION POINT

##### Gasoil pump

Cut the wire located at the position nr. D1 or D2 in the 10 way brown connector placed in the fuses holder box on the side of the battery.

#### STARTER

+ **50**: Cut the activation control wire of the relay of the starter located in the wiring harness coming out of the connector of the ignition key.

#### BONNET SWITCH

Install an additional switch on the front headlamp support plate, driver's side.

#### DOORS SWITCH

Connect to the VIOLET wire located in the wiring harness behind the sill cover, driver's side.

#### BOOT SWITCH

Connect to the ORANGE wire marked 319 located directly on the coming out of the boot lamp.



CAR SECURITY

SPECIFIC VEHICLE ALARM FITTING INSTRUCTIONS

REV. 00

www.cobra.it

FITTING DIAGRAM N° 93

Diagram for the connection of art. 3800 on  
**PEUGEOT 106**

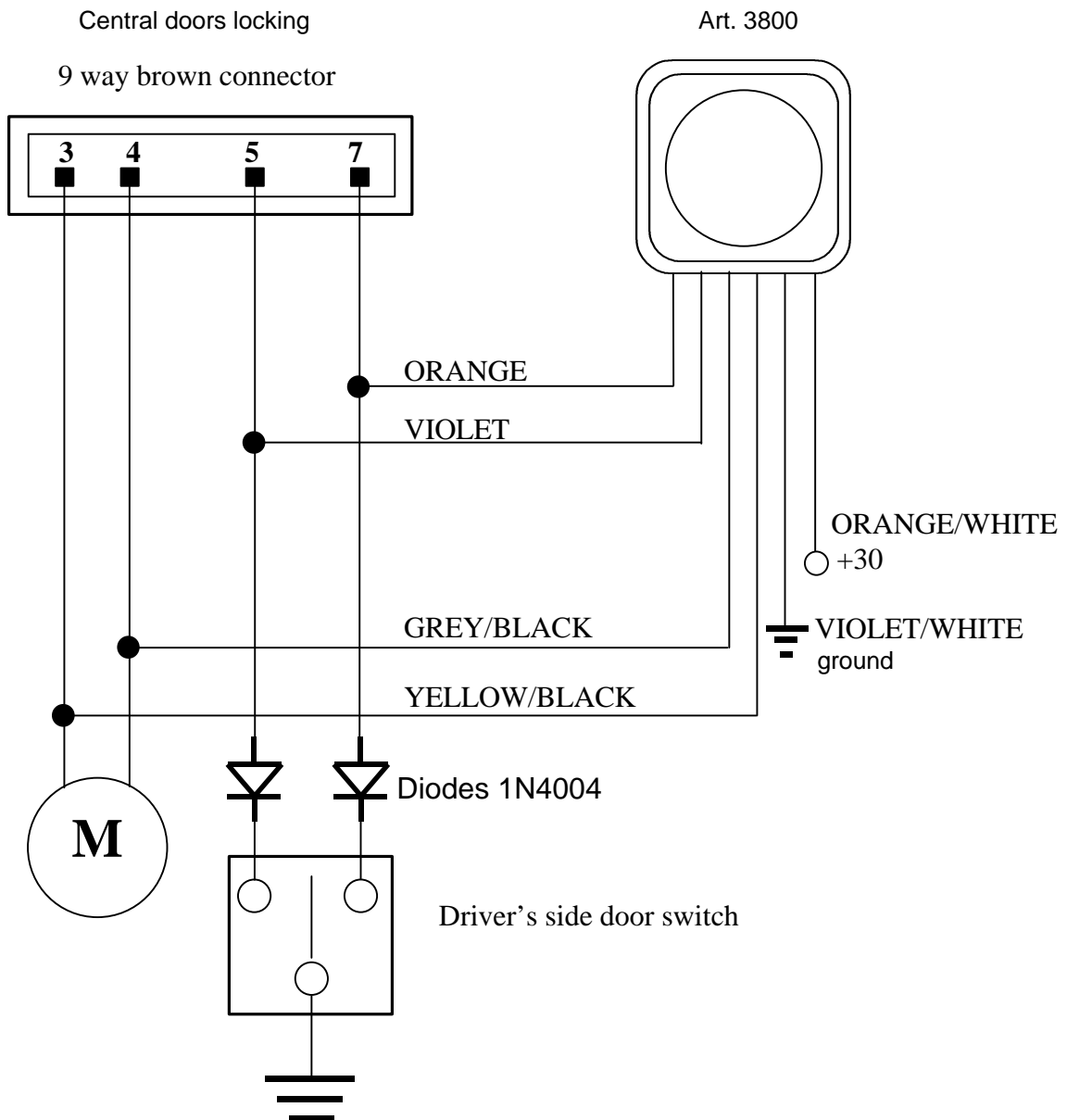

The central unit of the central doors locking is located behind the driver's side air spout. In order to go in it is suggested to take off the annexe pipe.