



**quasar**  
e l e c t r o n i c s

**QUASAR ELECTRONICS**  
ul. Cie lewskich 25 k  
03-017 Warszawa  
tel.(022) 678-68-96, 678-64-50

**www: <http://www.quasarelectronics.pl>**

**e-mail: [biuro@quasarelectronics.pl](mailto:biuro@quasarelectronics.pl)**



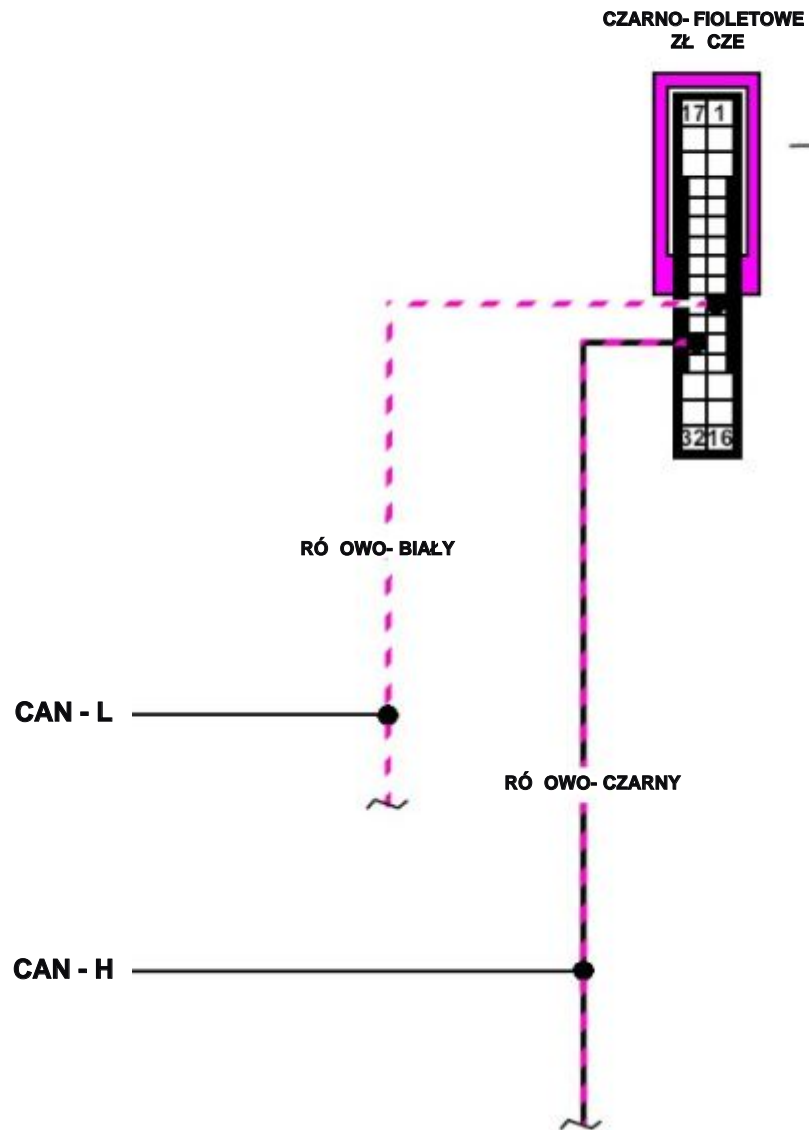

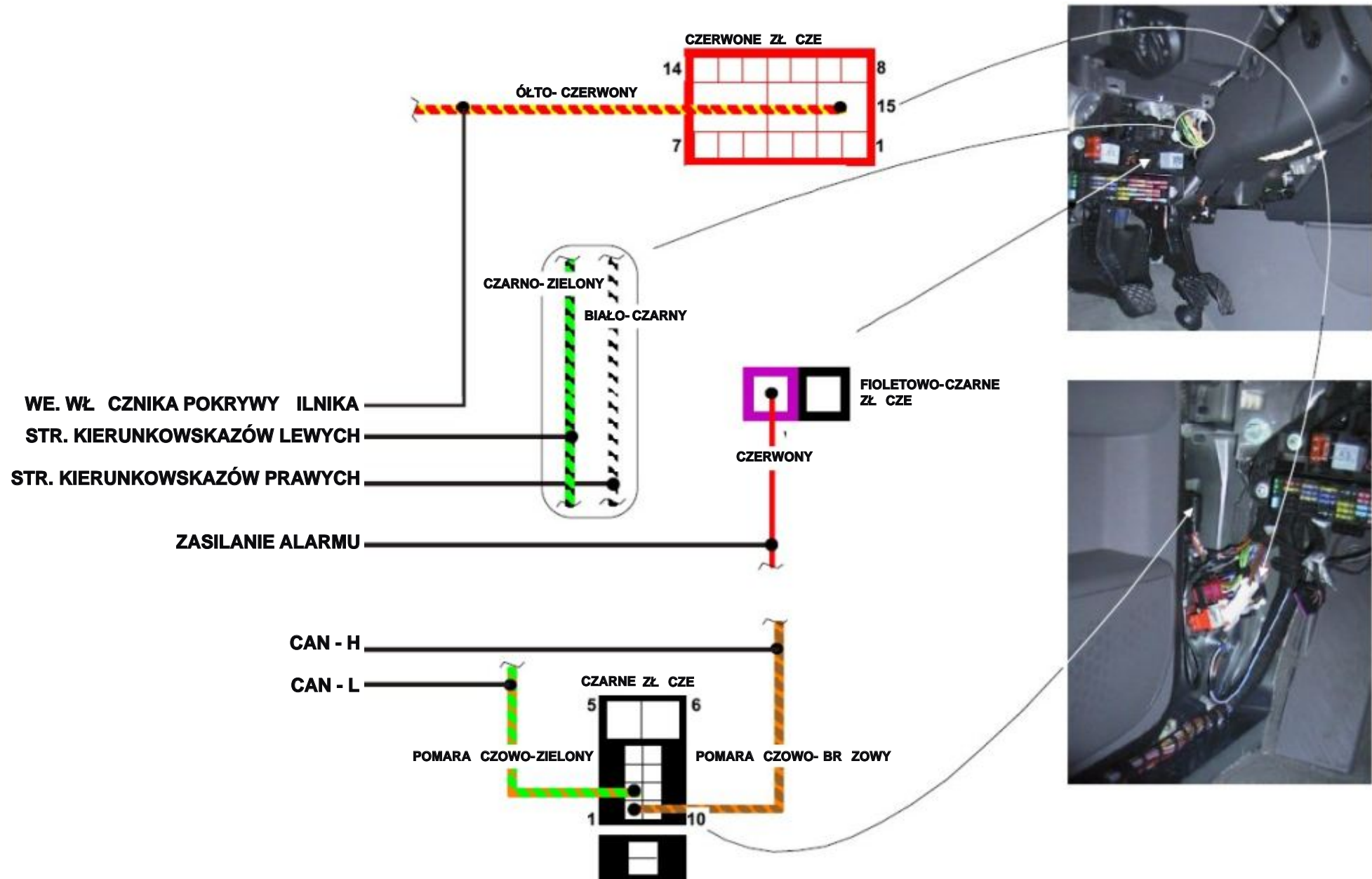



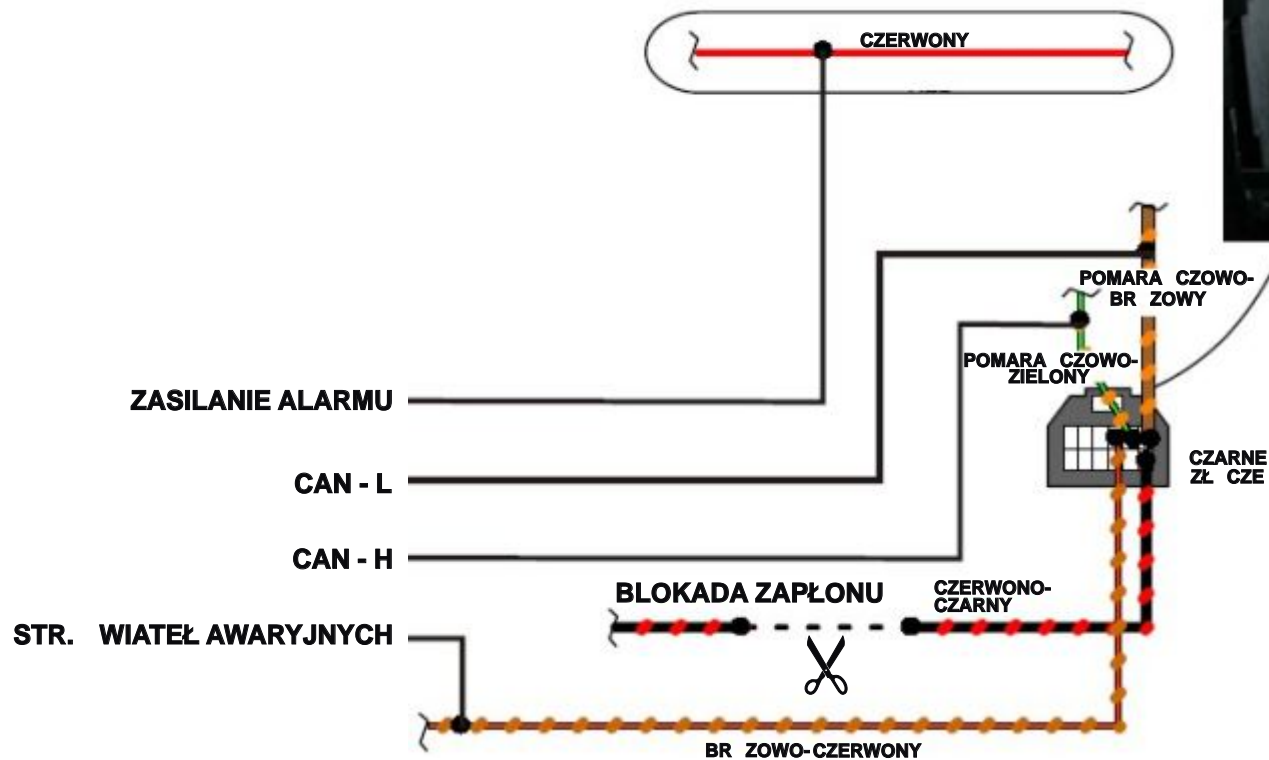
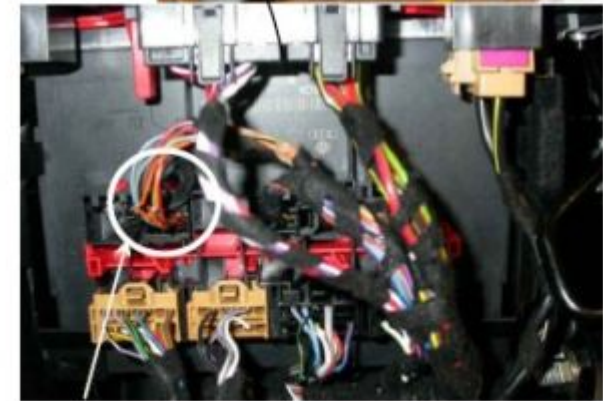
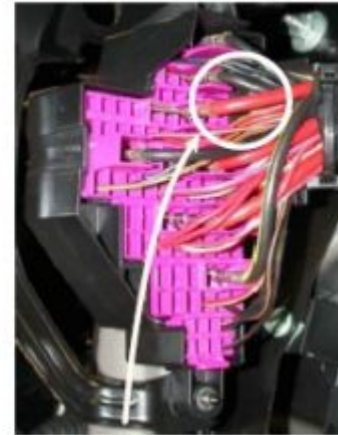

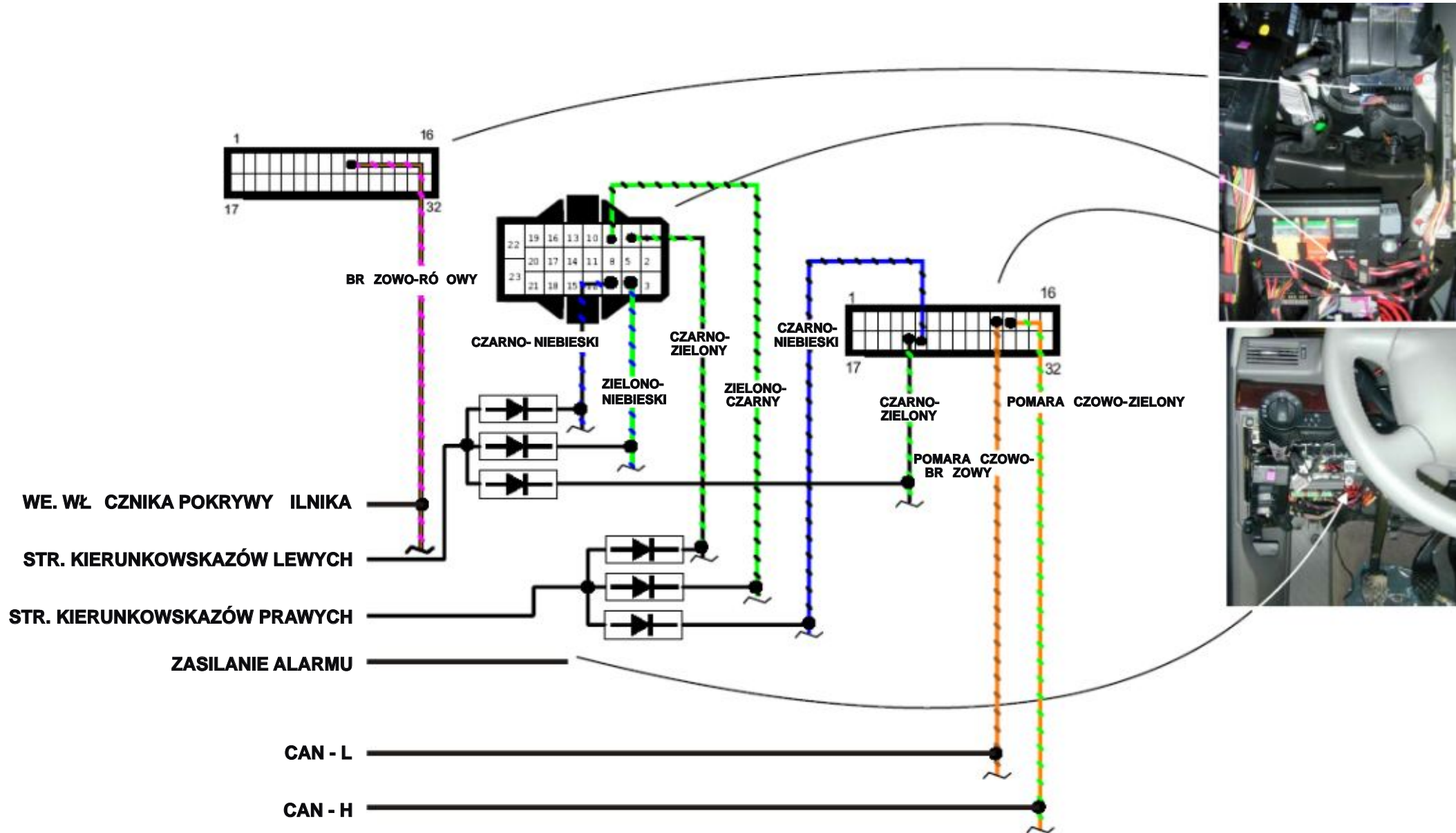

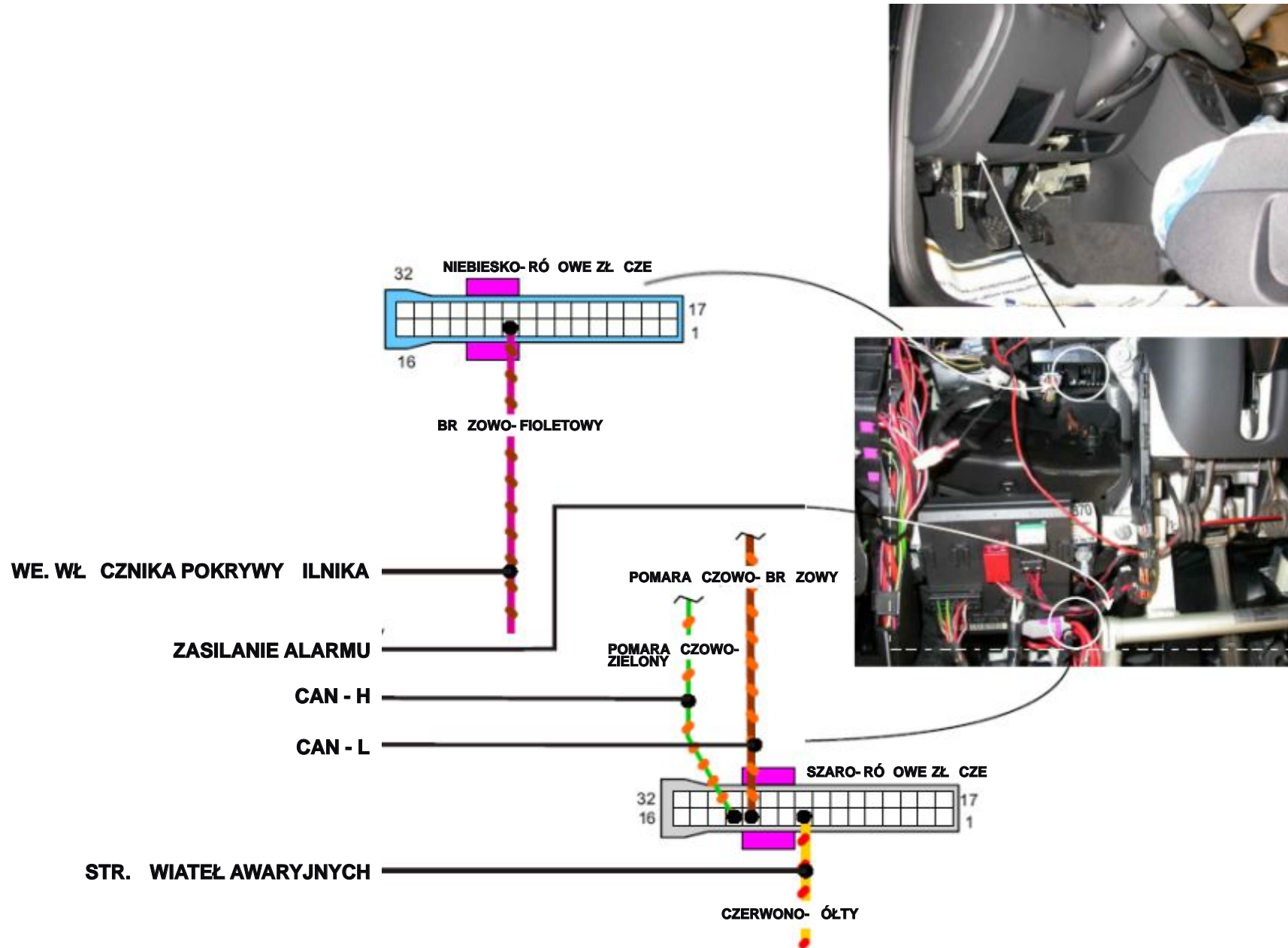



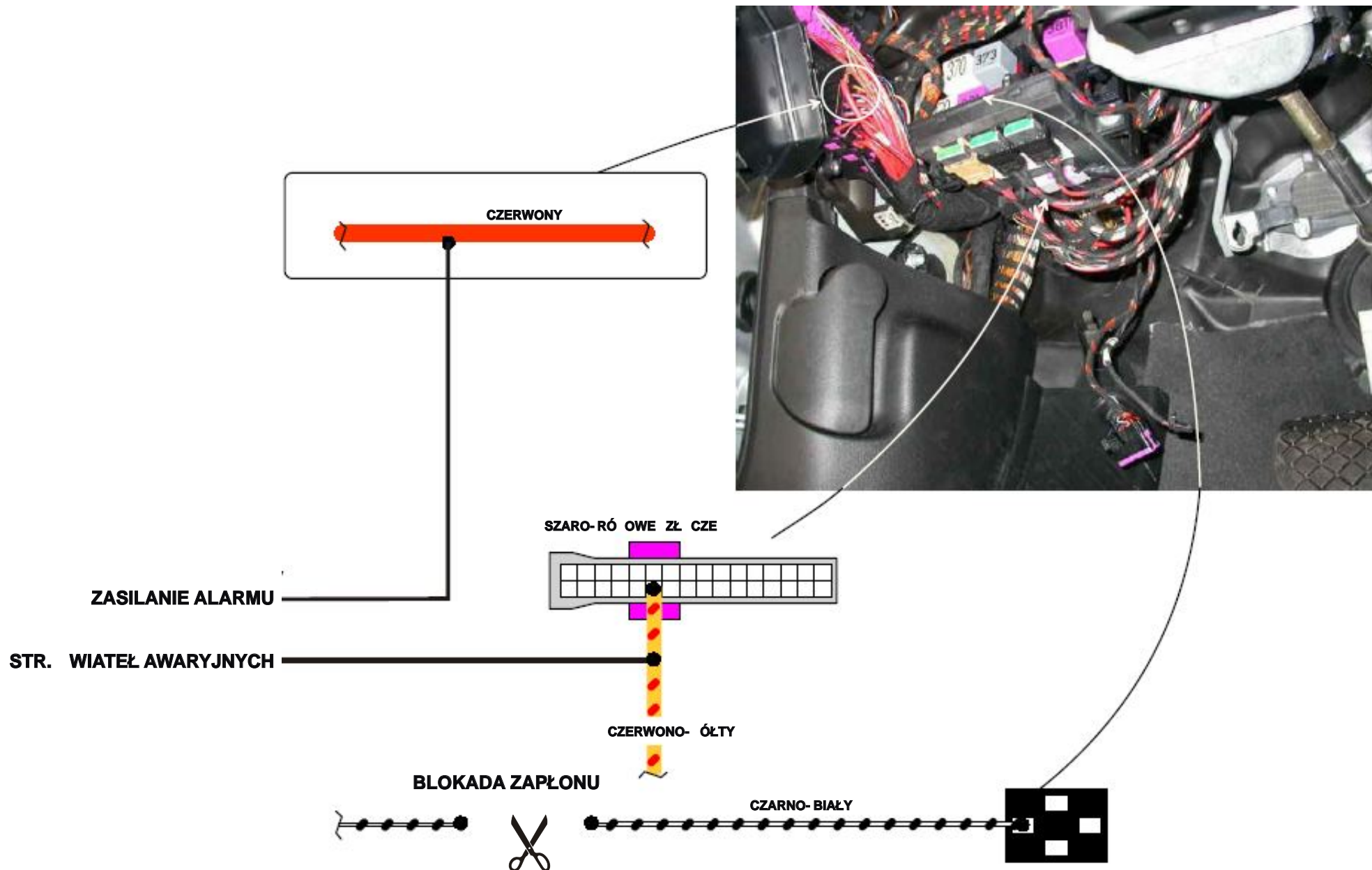



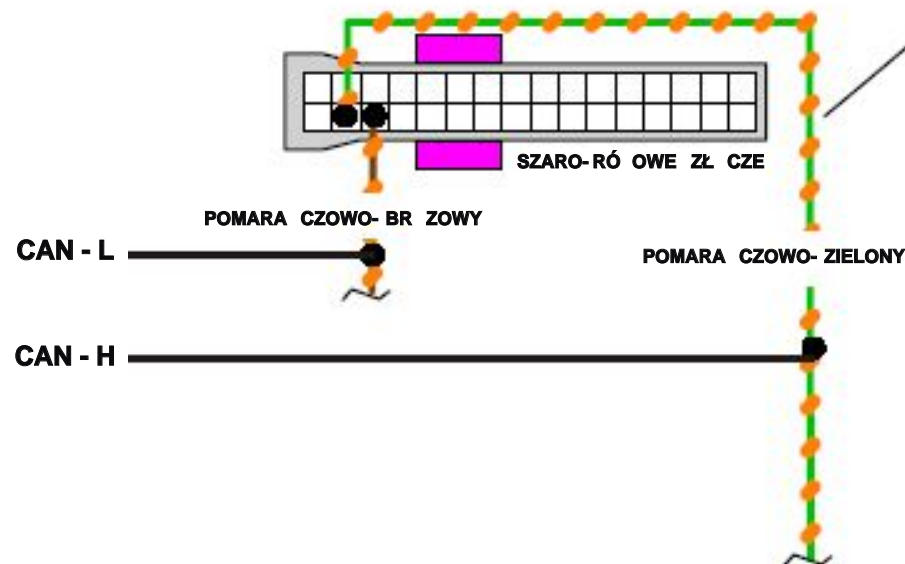

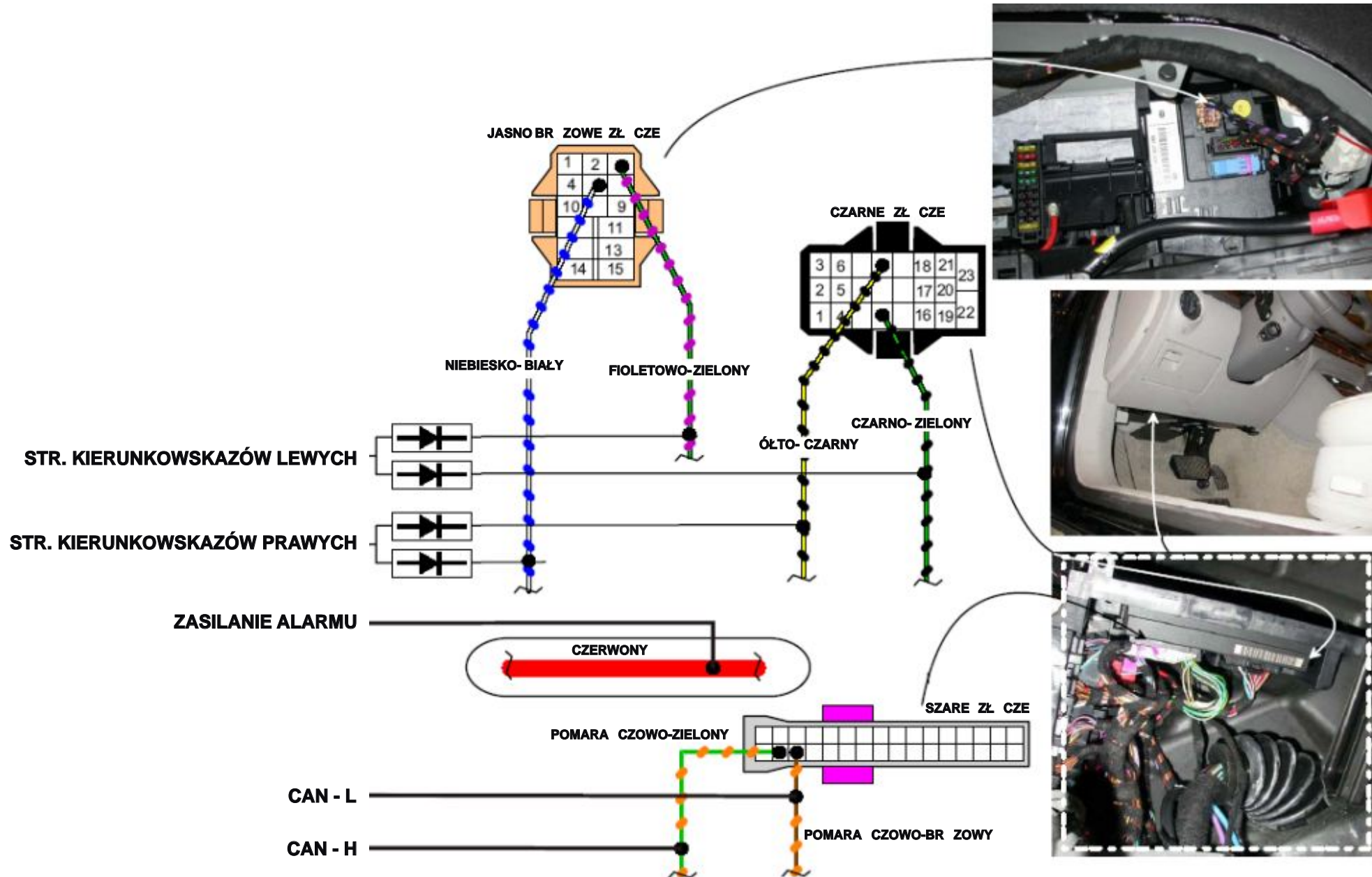

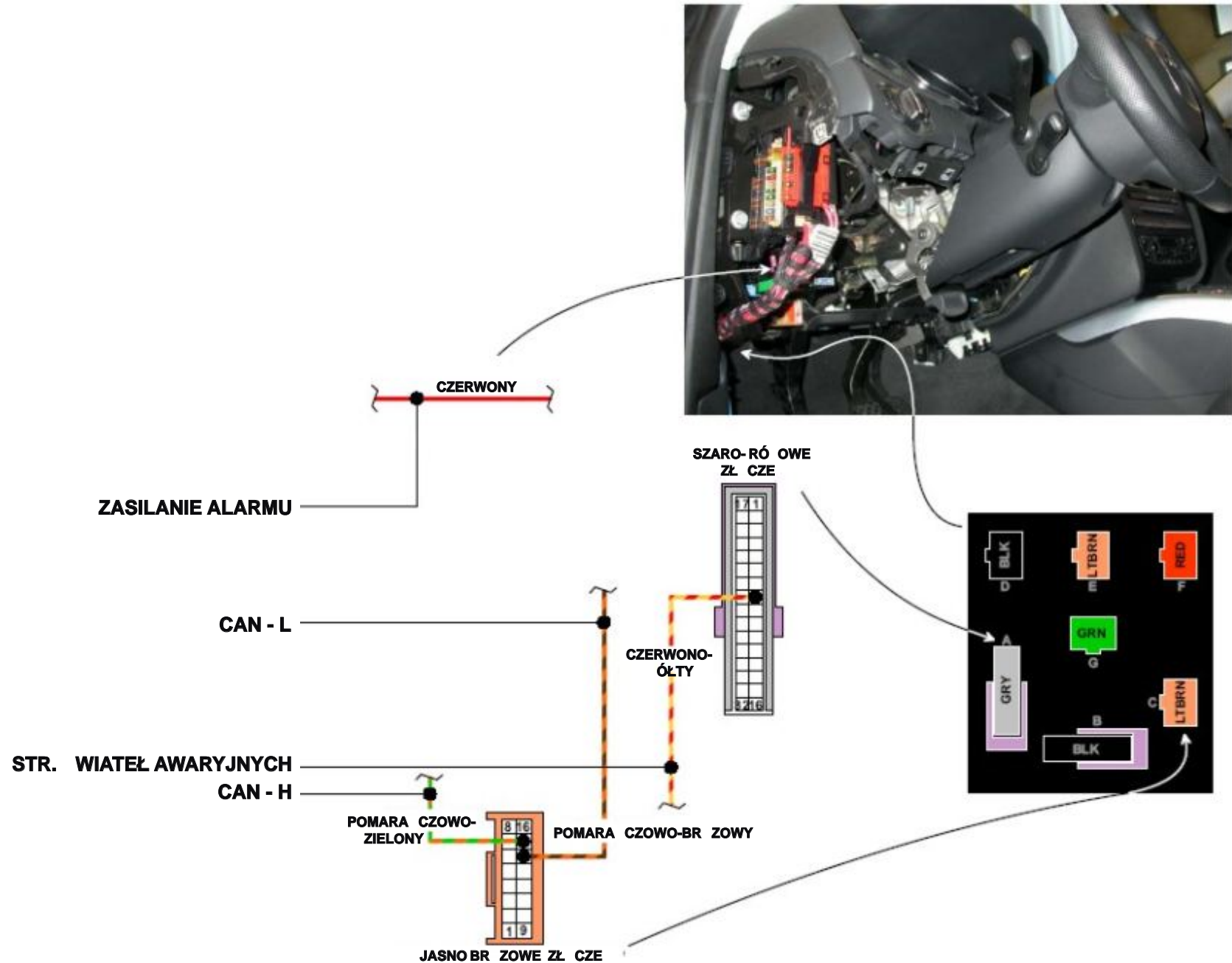



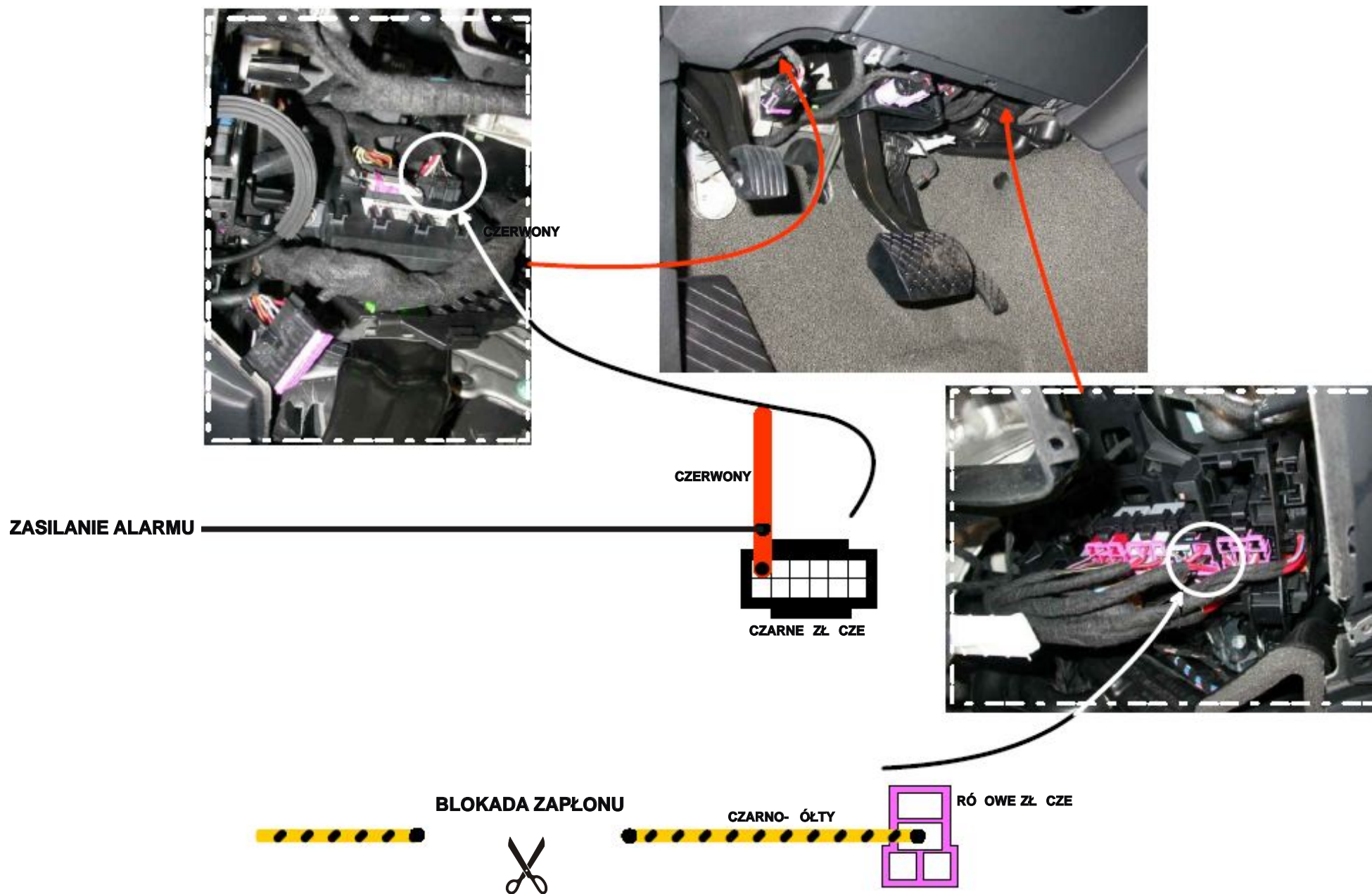



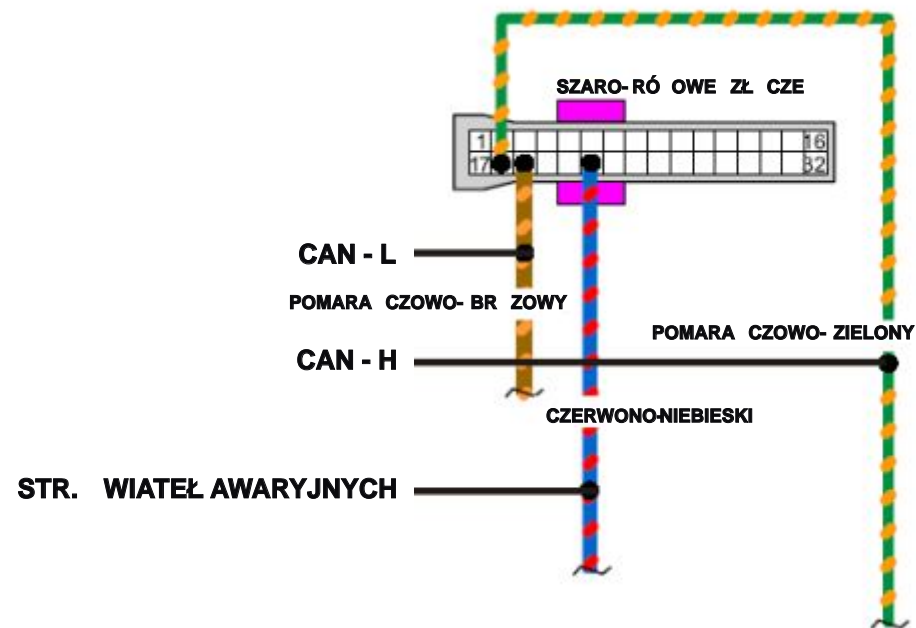

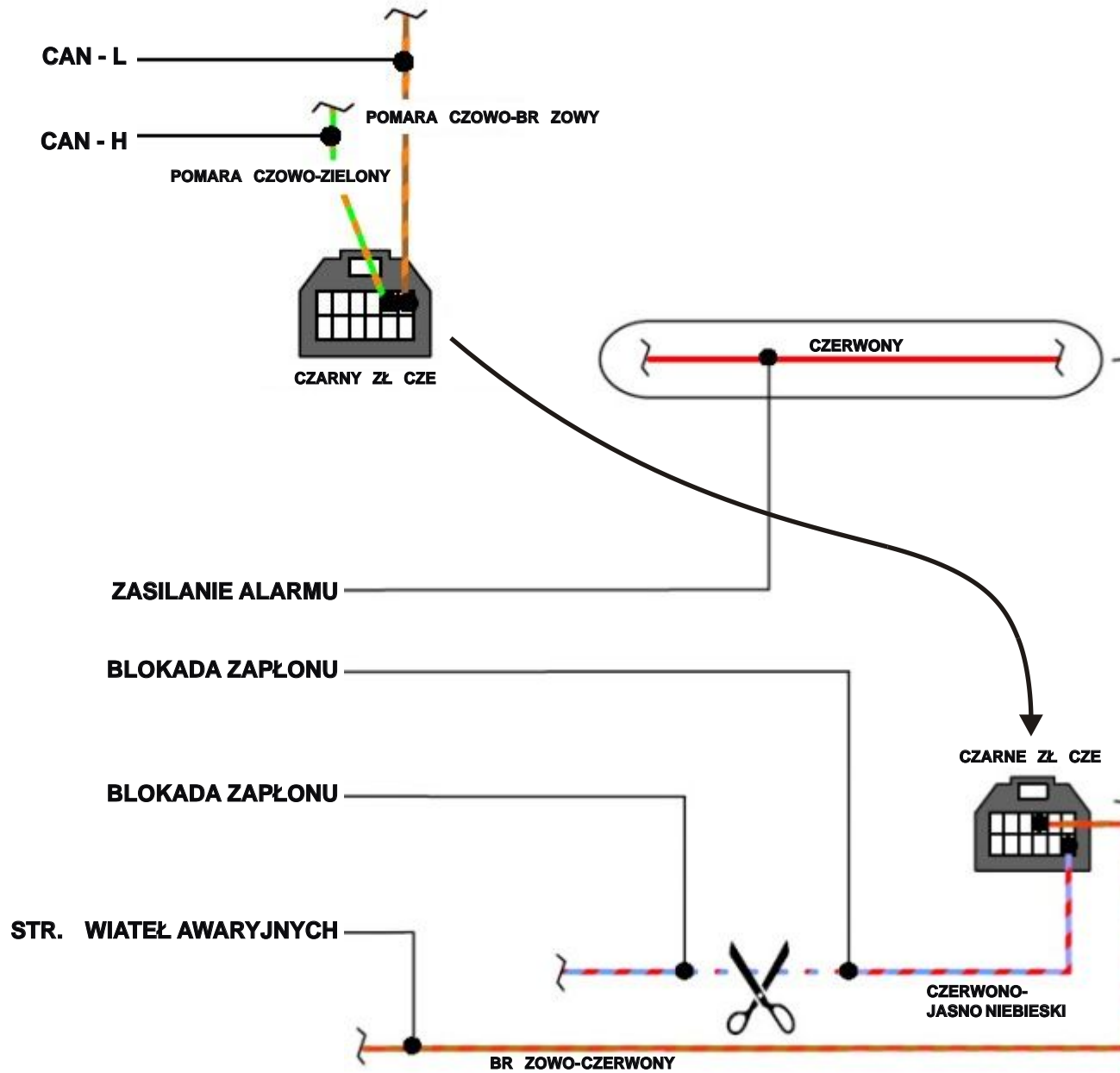

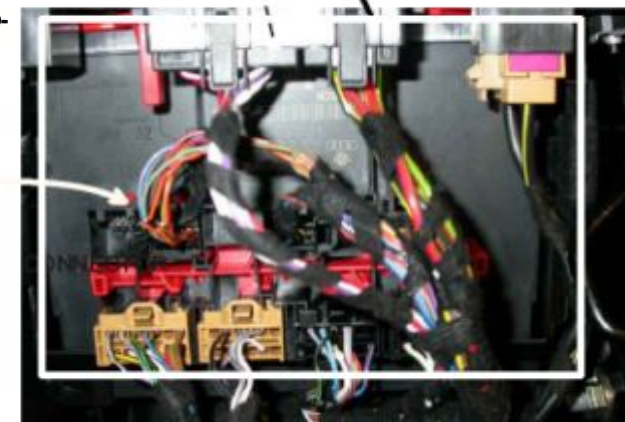
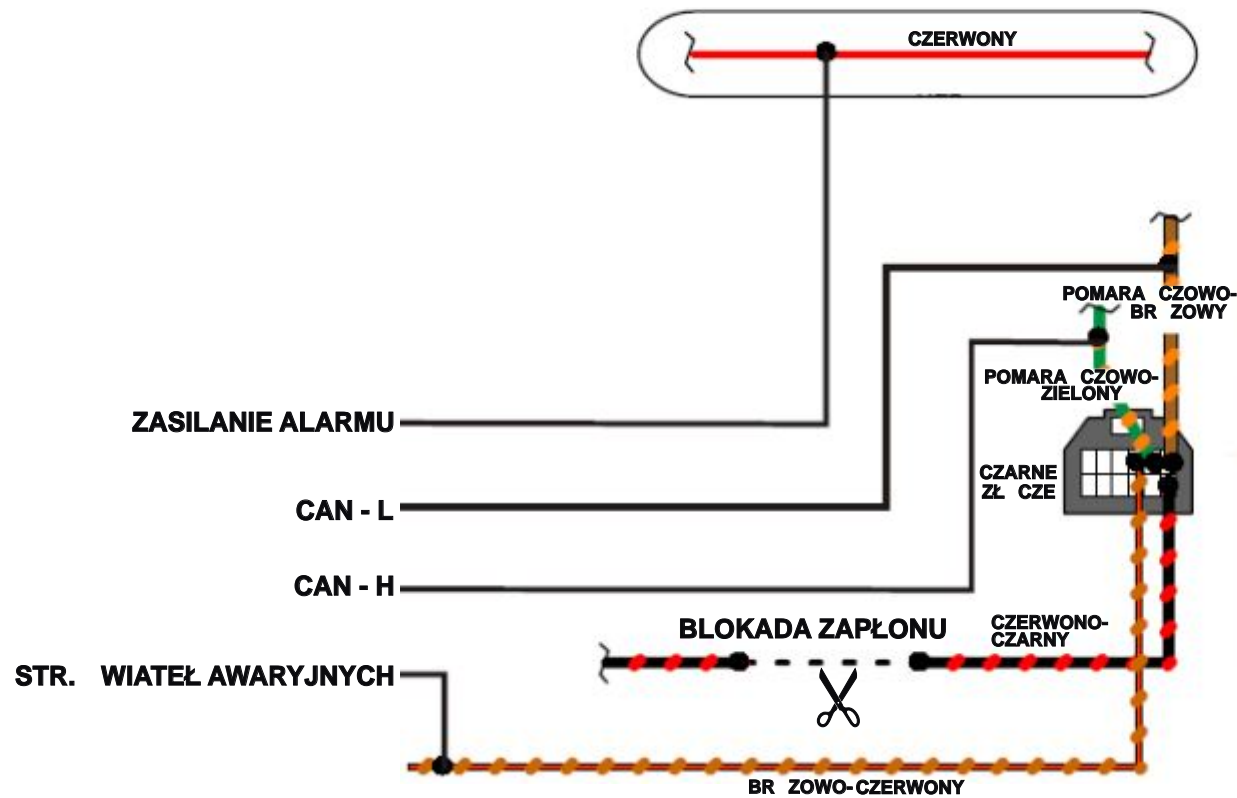
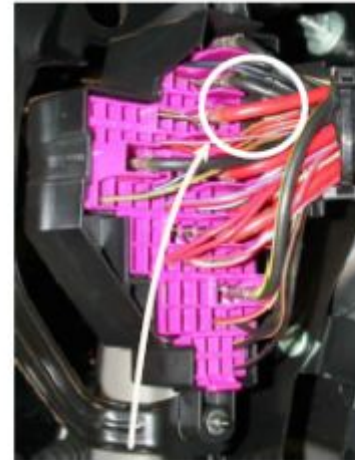







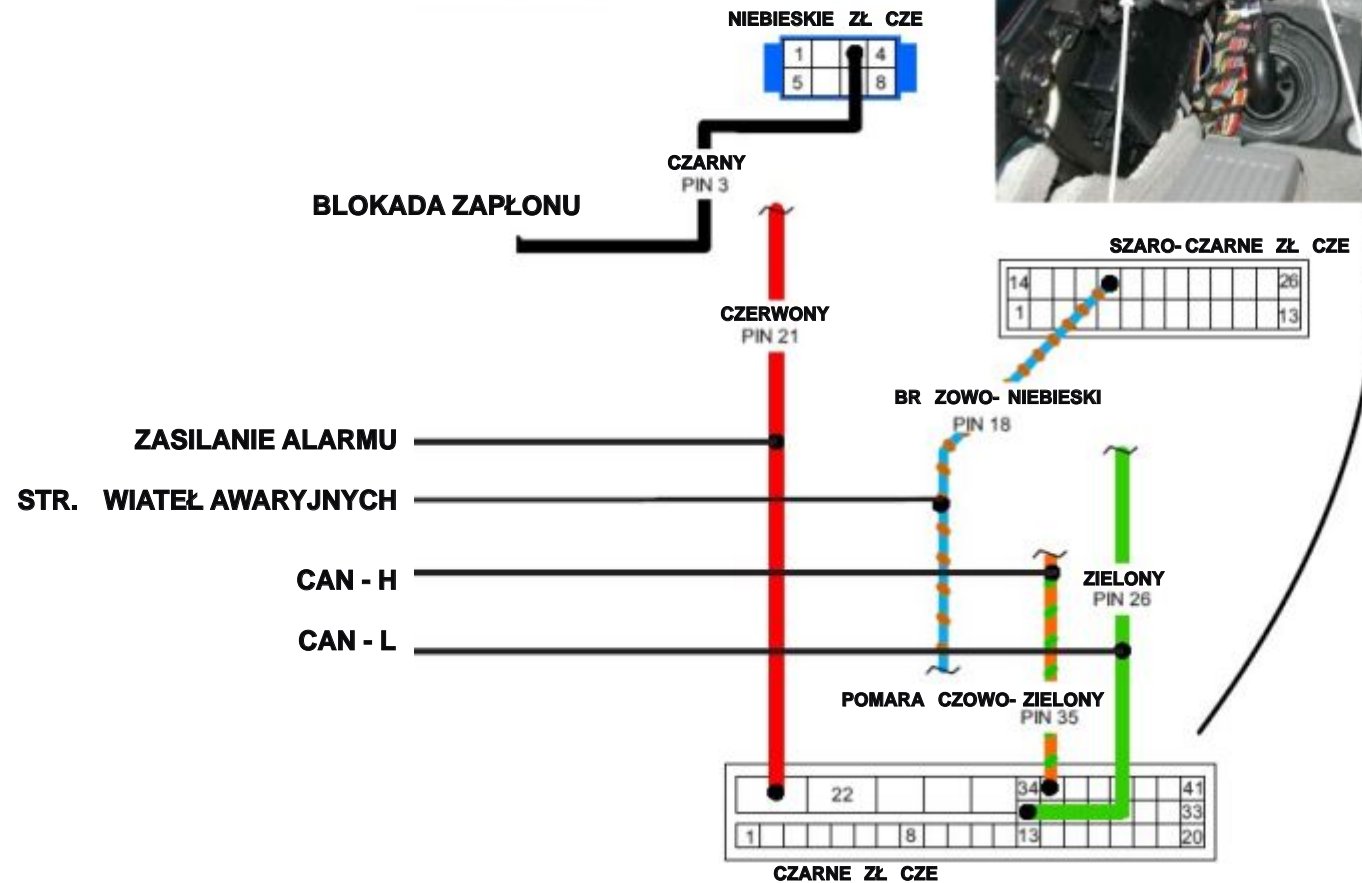
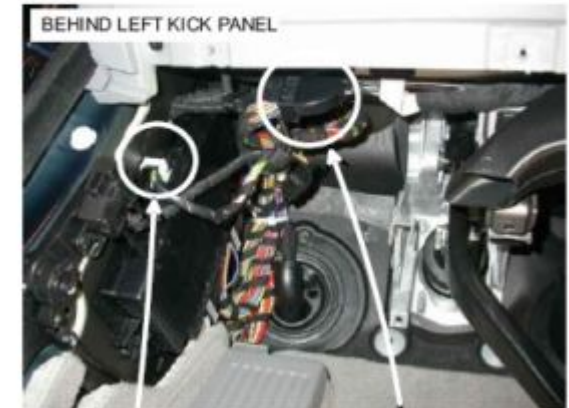

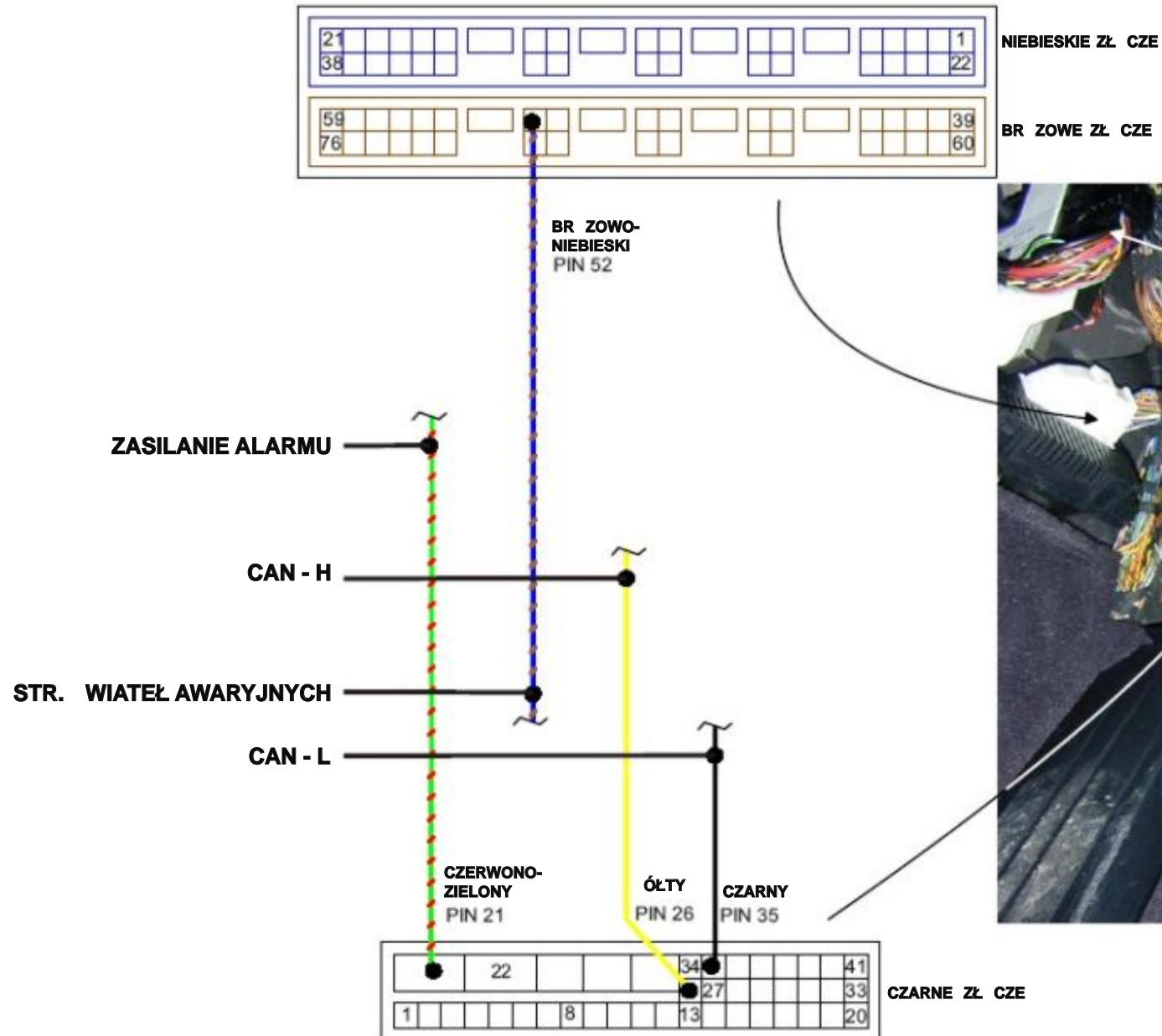

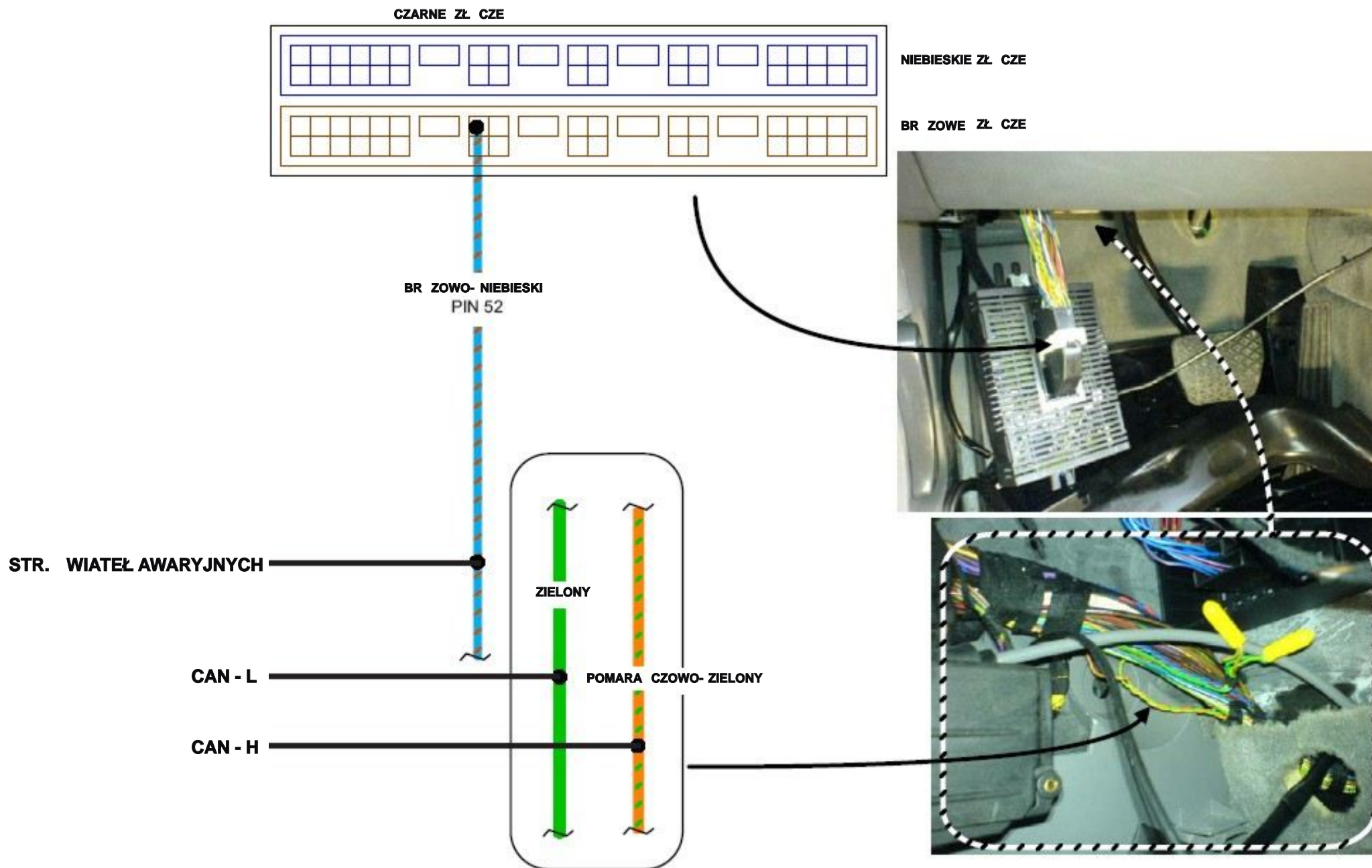









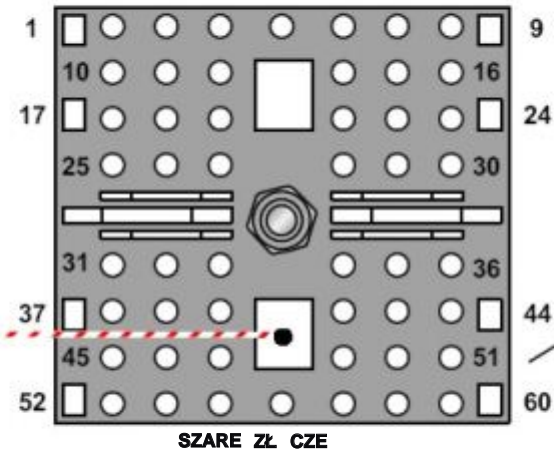

CZERWONO-BIAŁY  
PIN 48

ZASILANIE ALARMU  
BLOKADA ZAPŁONU  
BLOKADA ZAPŁONU



ÓŁTY  
PIN 22

CZARNE ZŁ. CZE

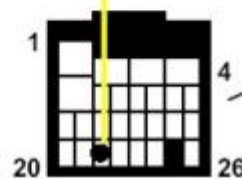

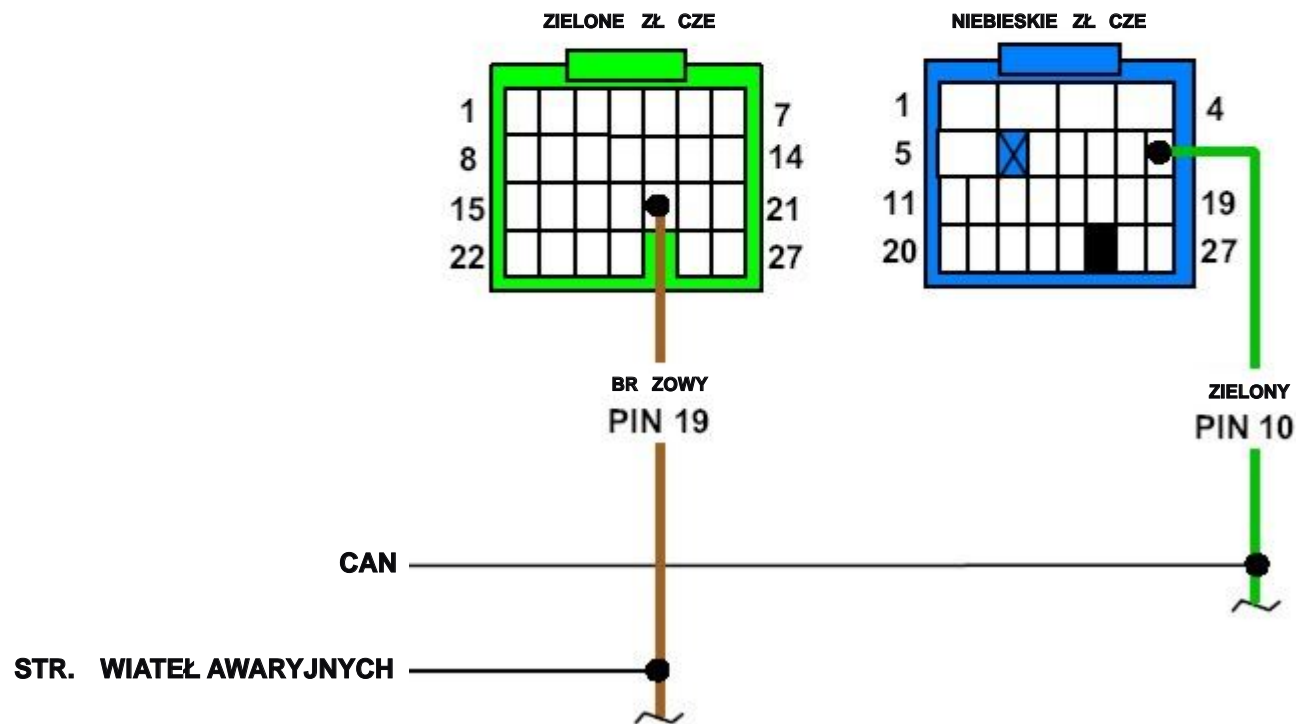



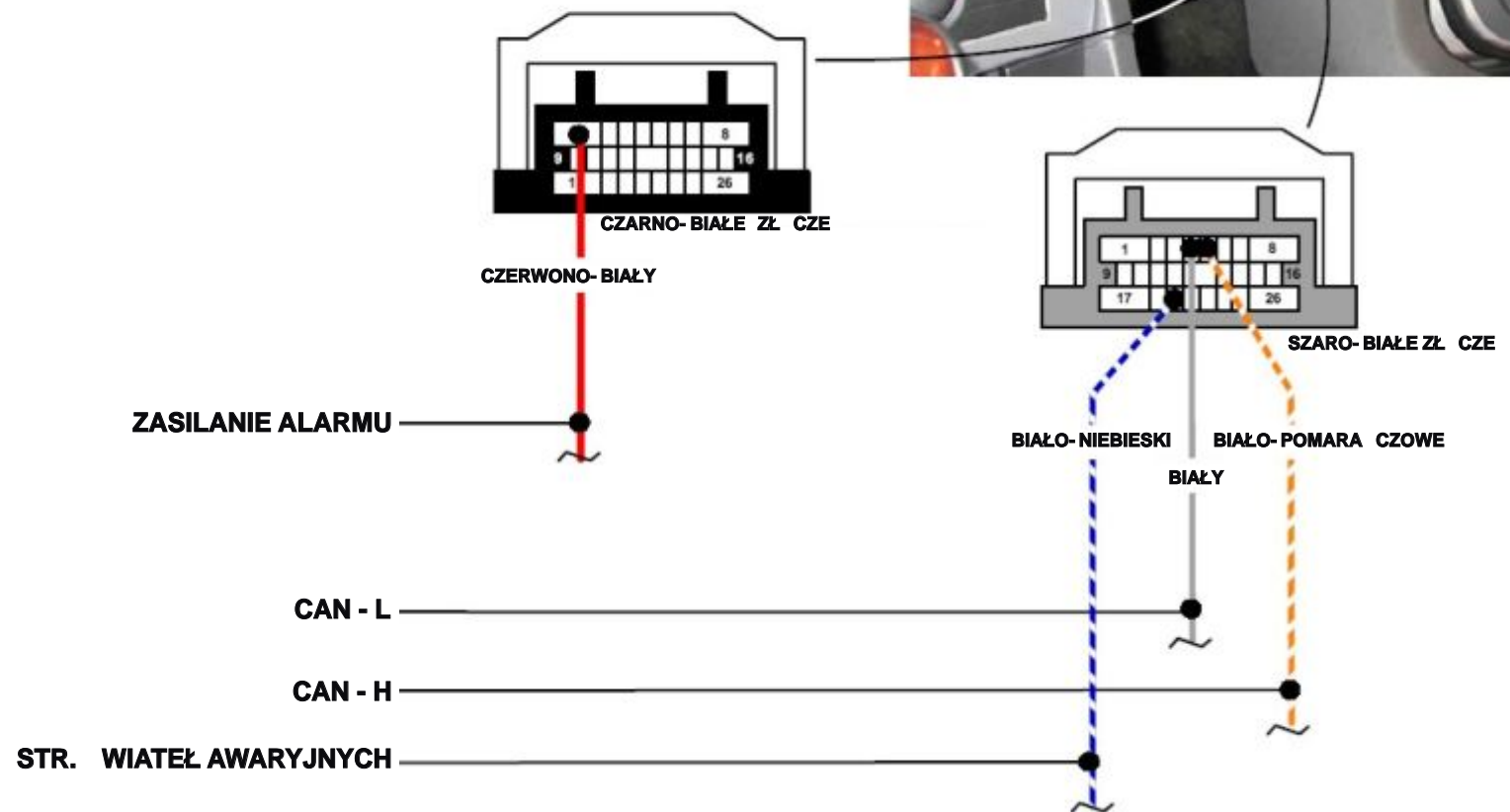

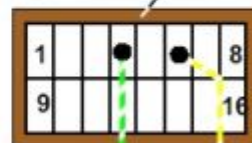

STR. KIERUNKOWSKAZÓW LEWYCH  
STR. KIERUNKOWSKAZÓW PRAWYCH  
ZASILANIE ALARMU

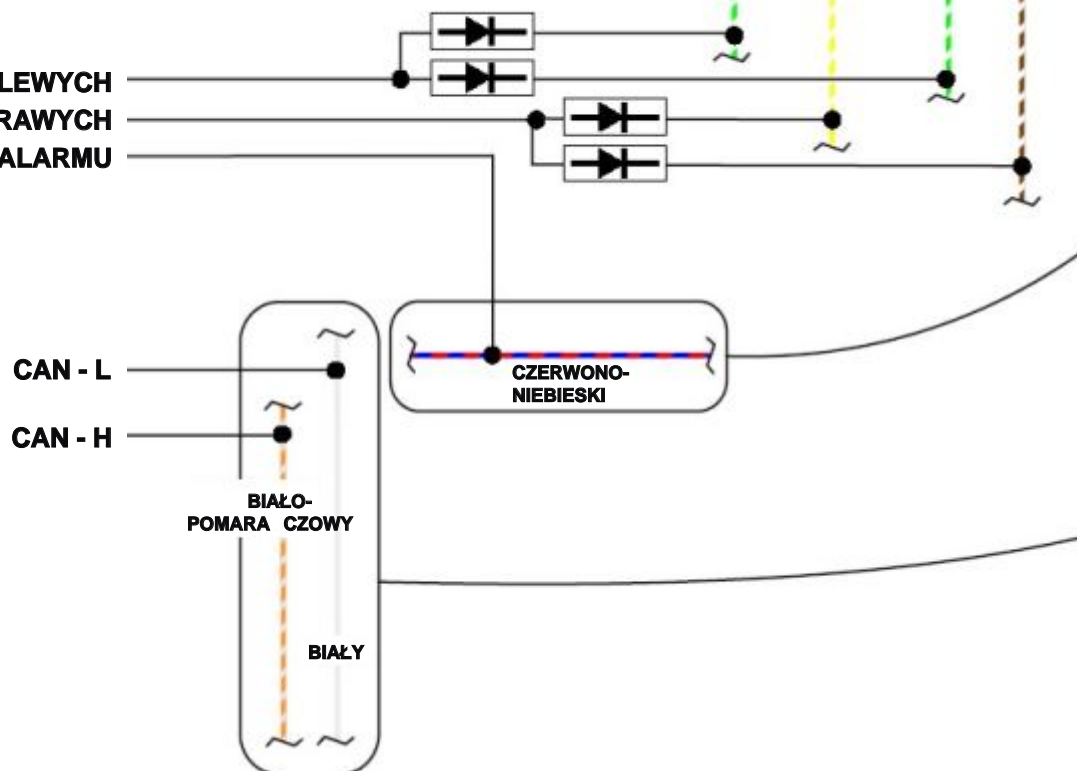

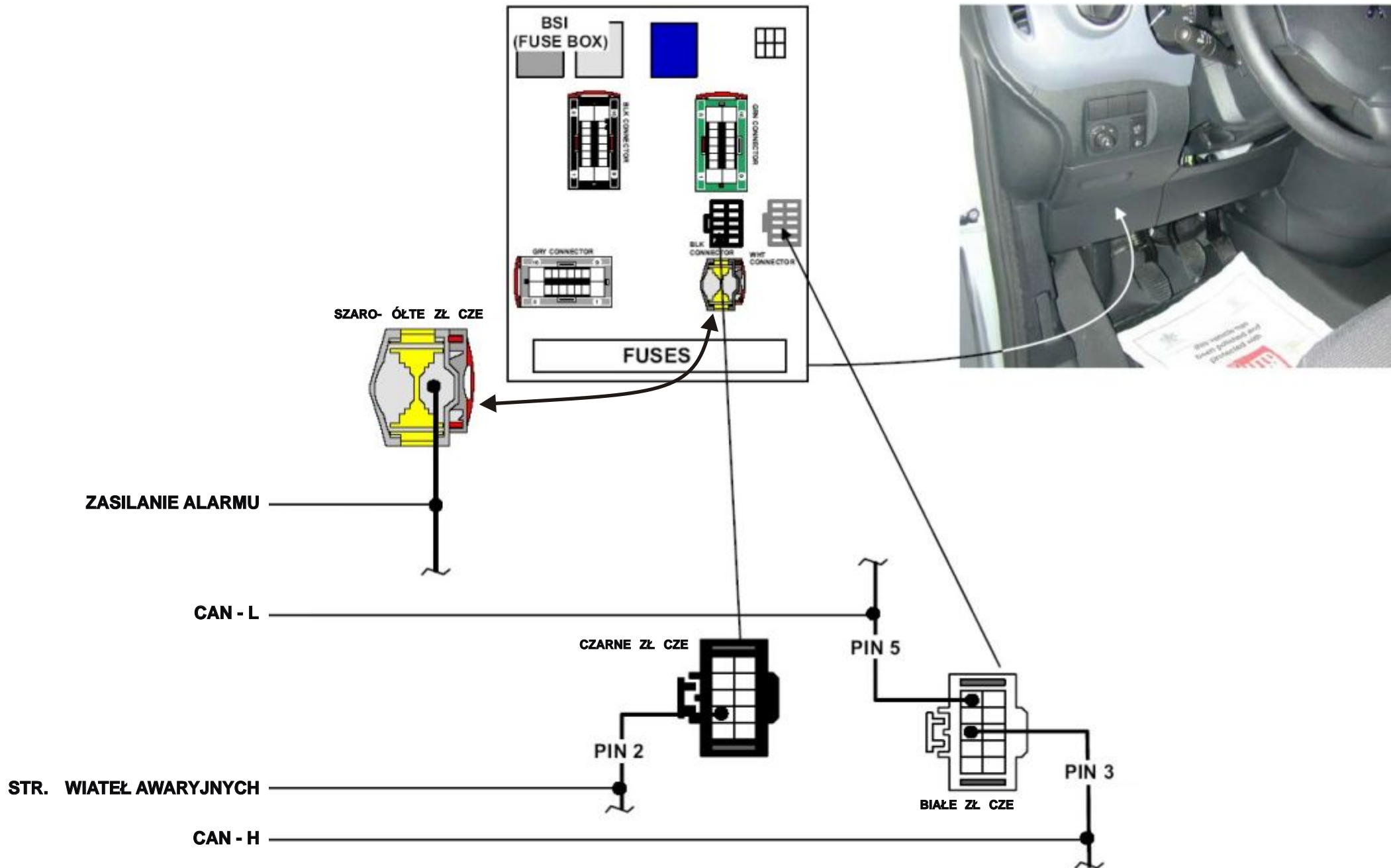



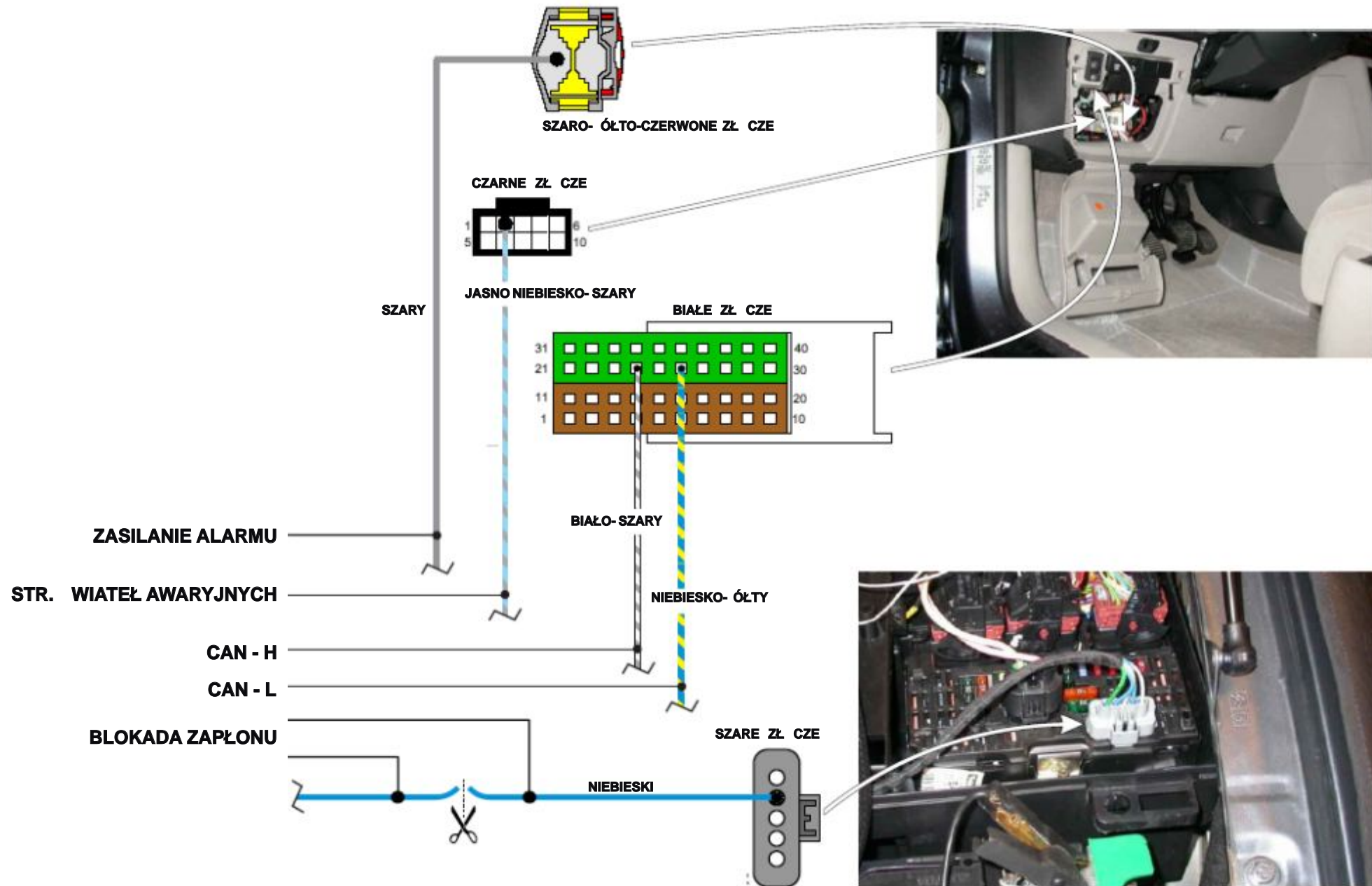

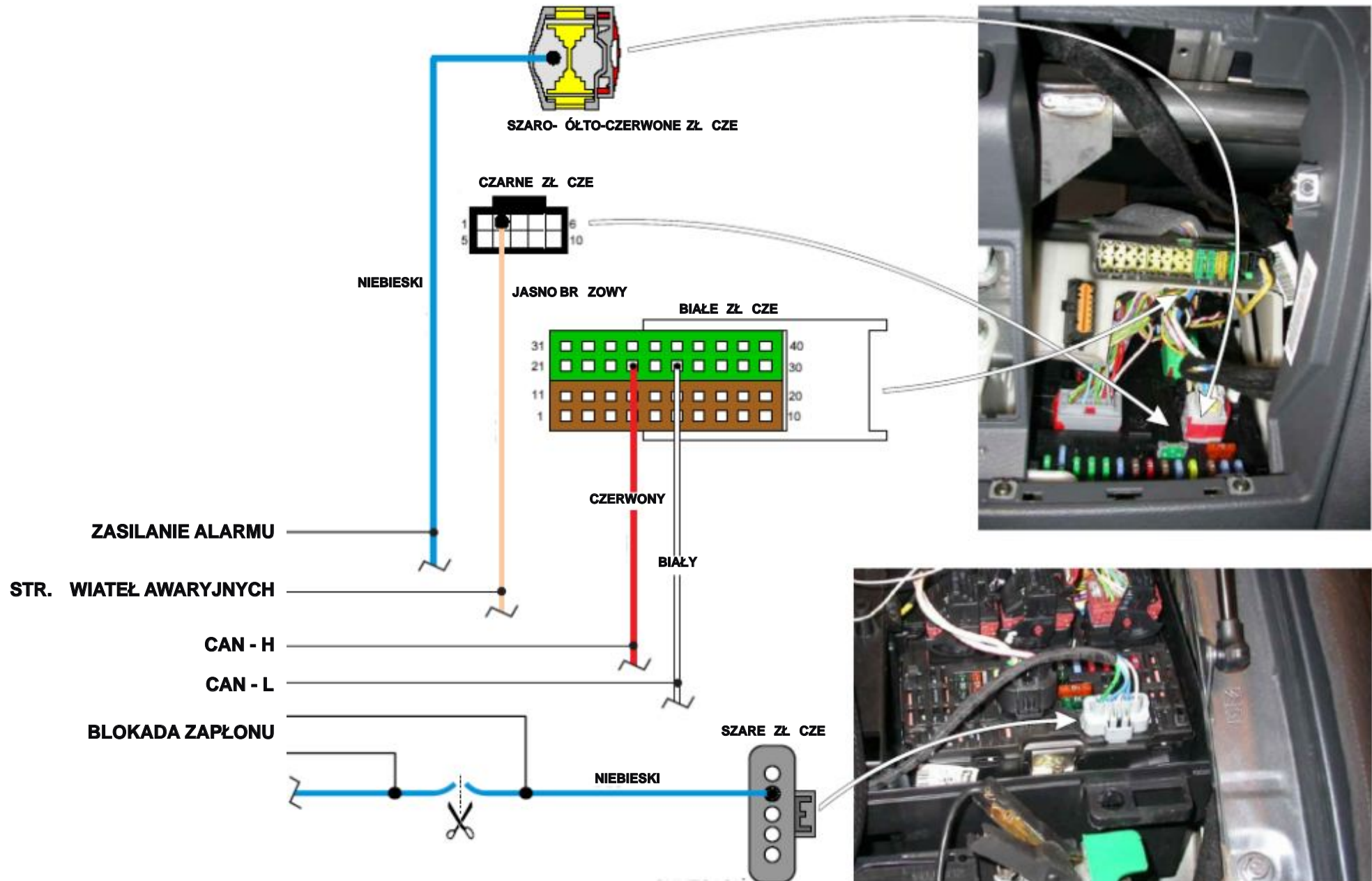

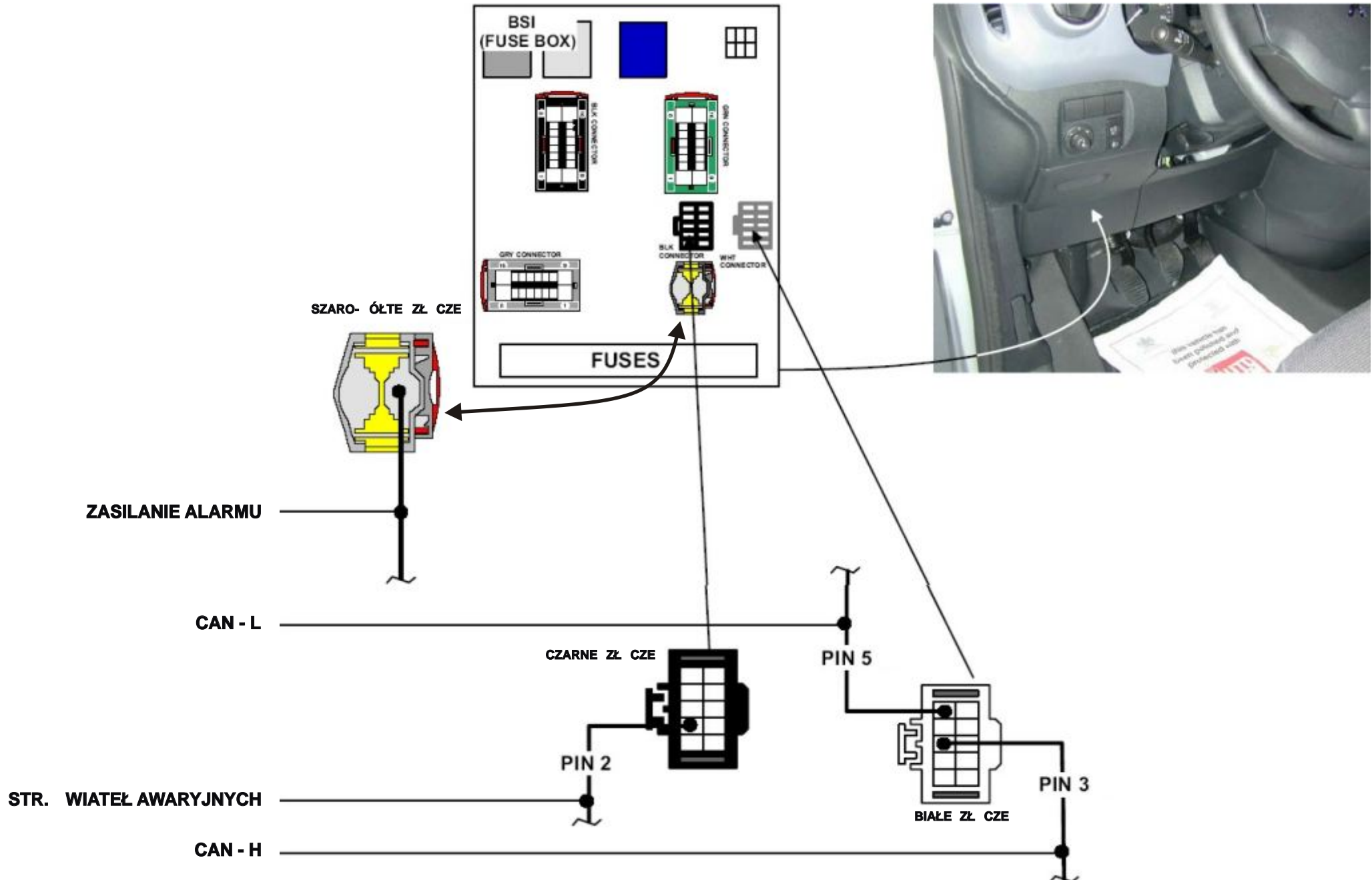



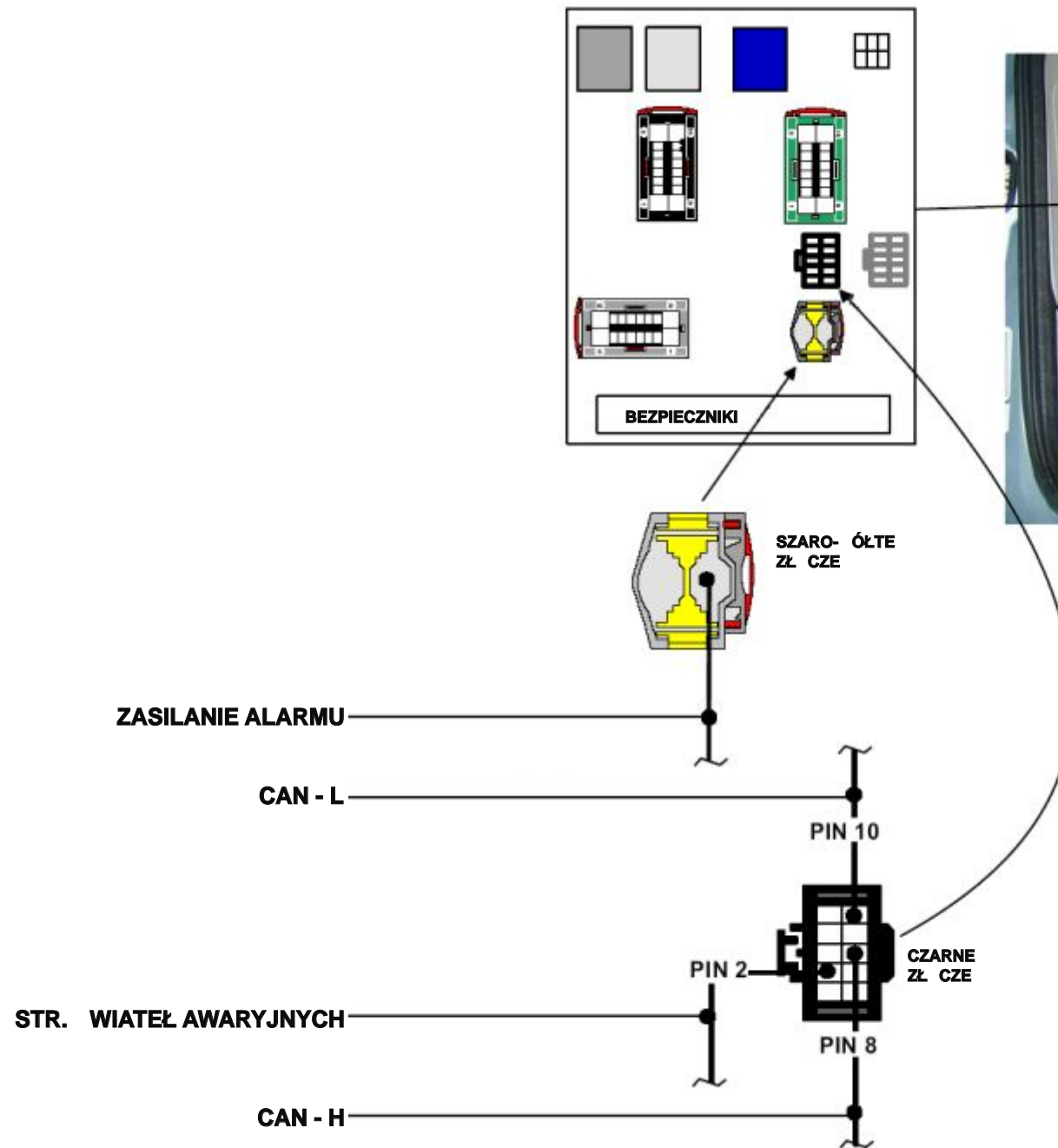

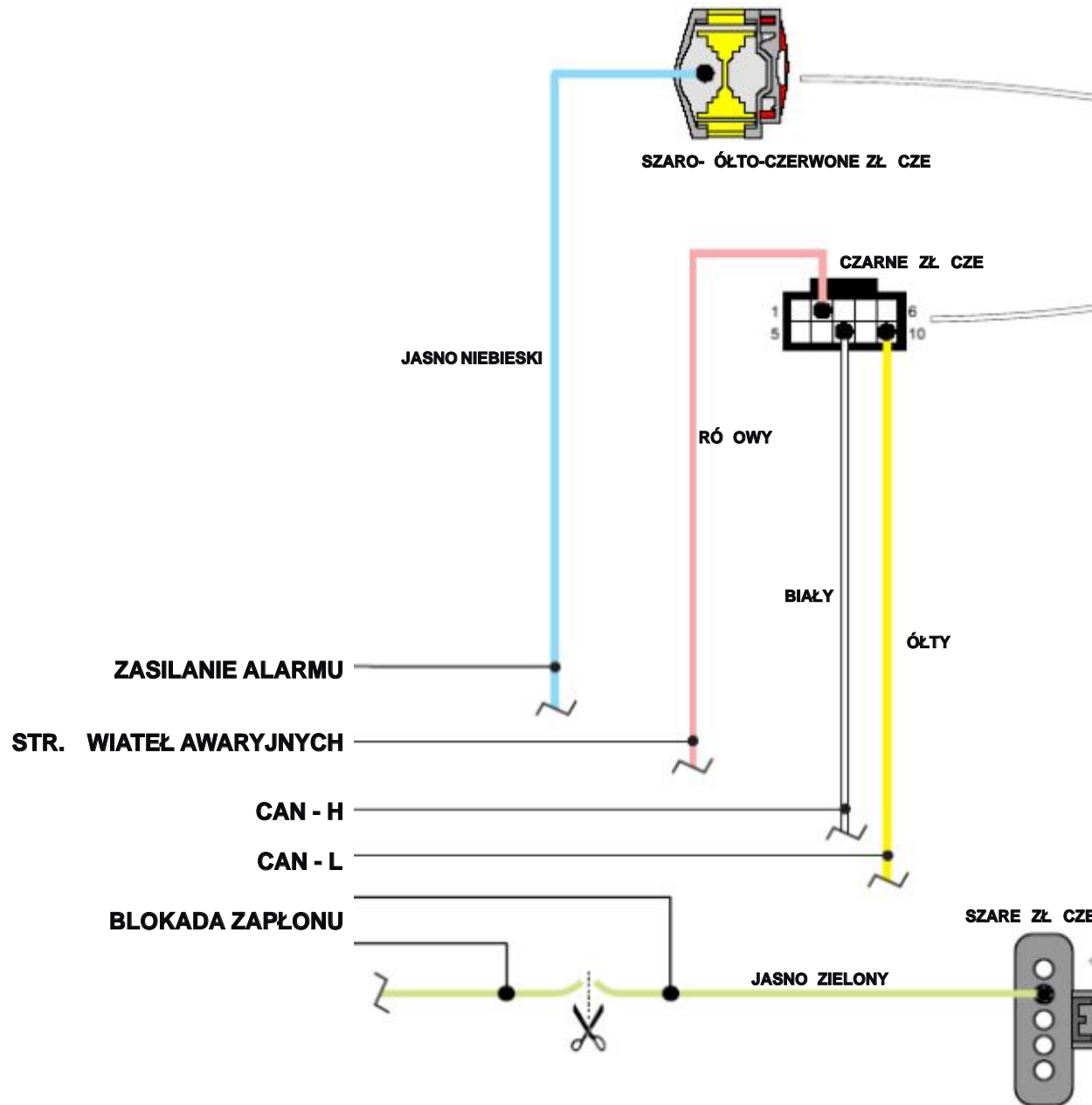





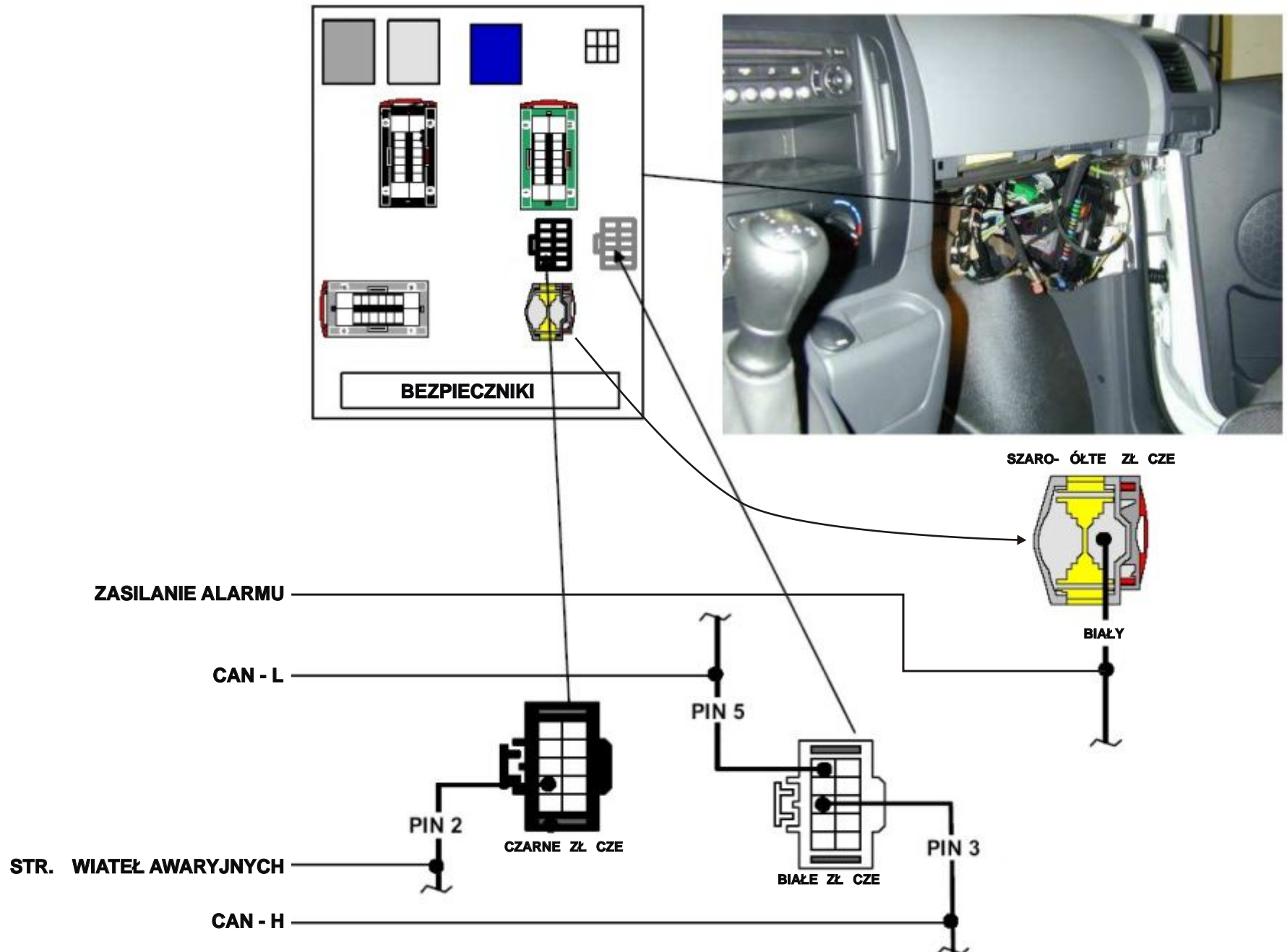

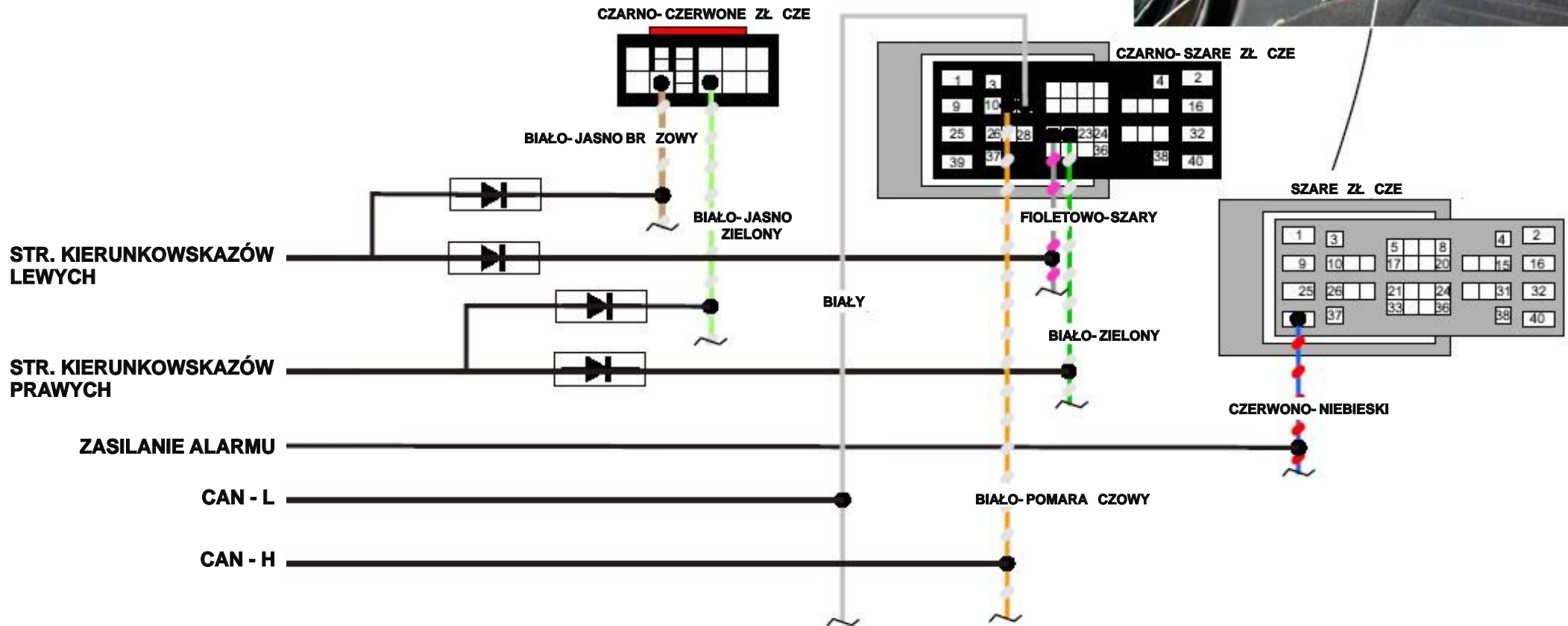

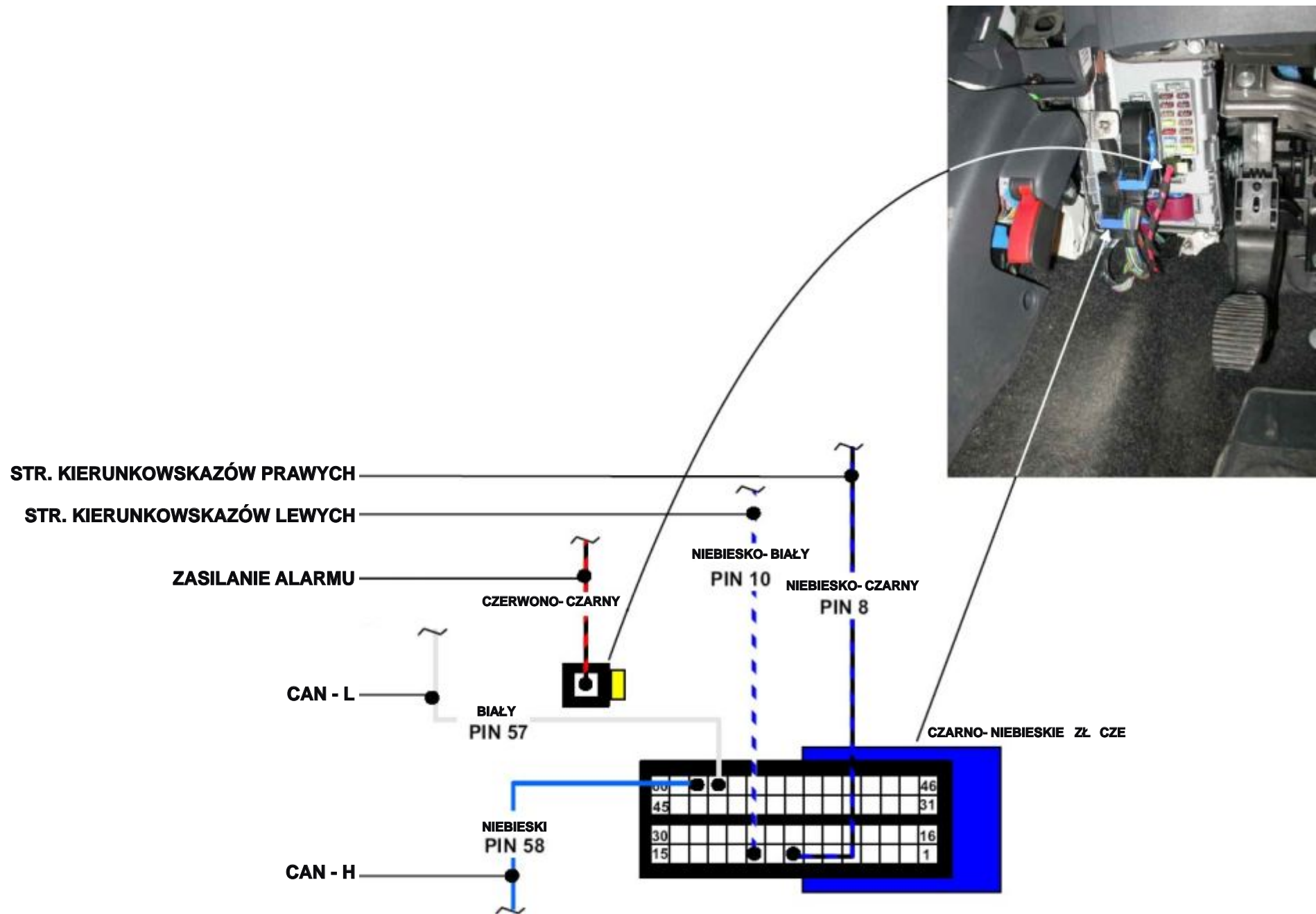

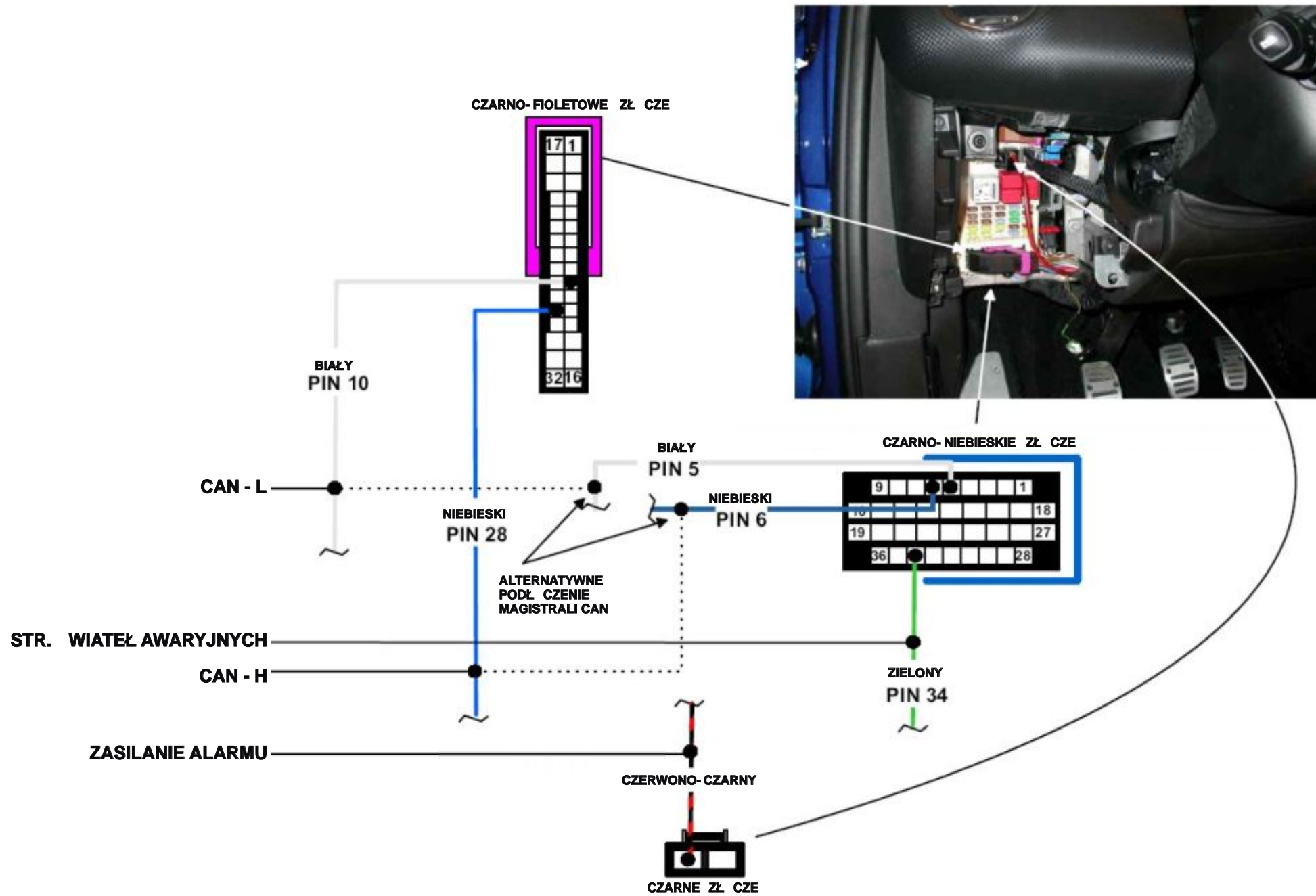









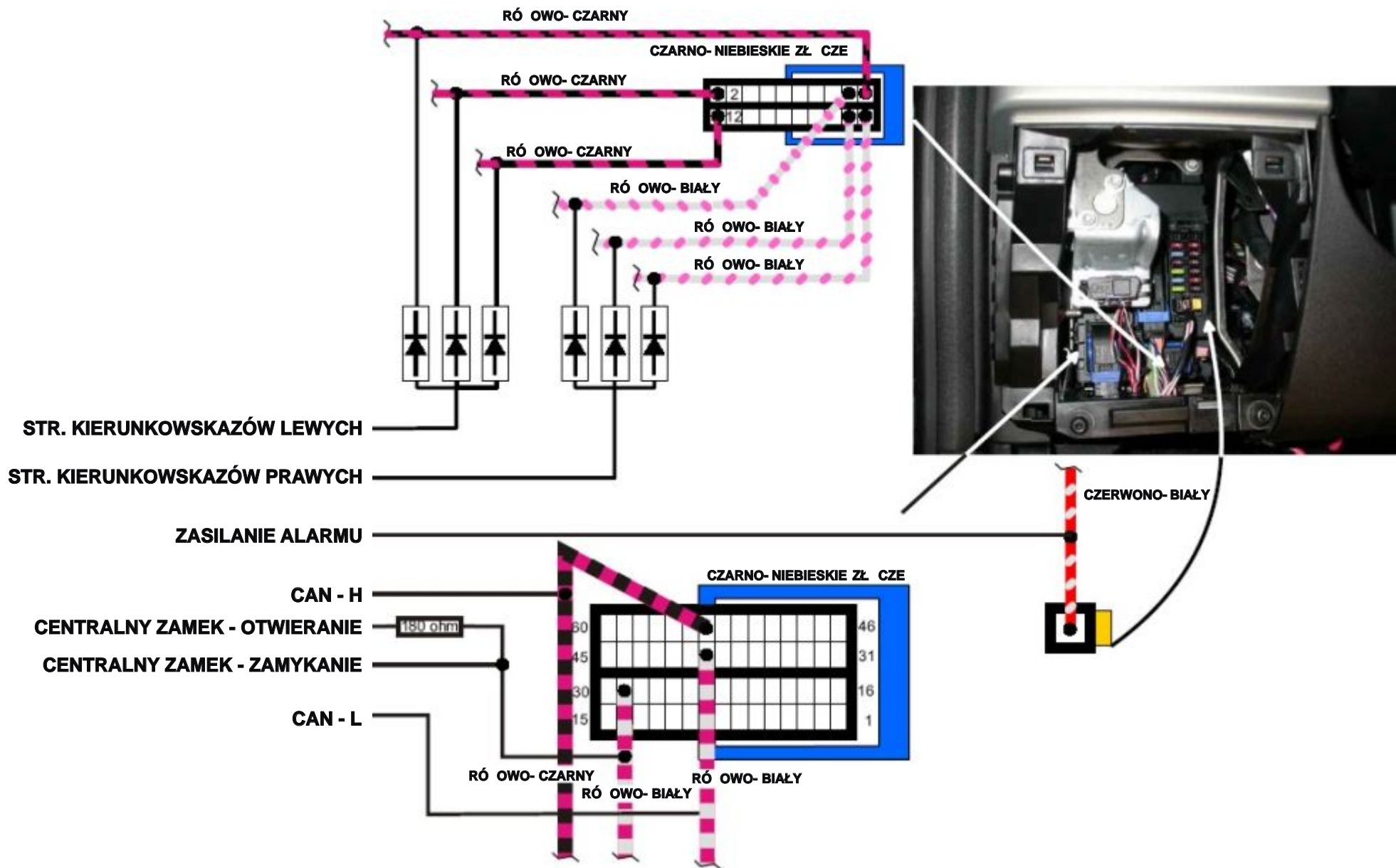



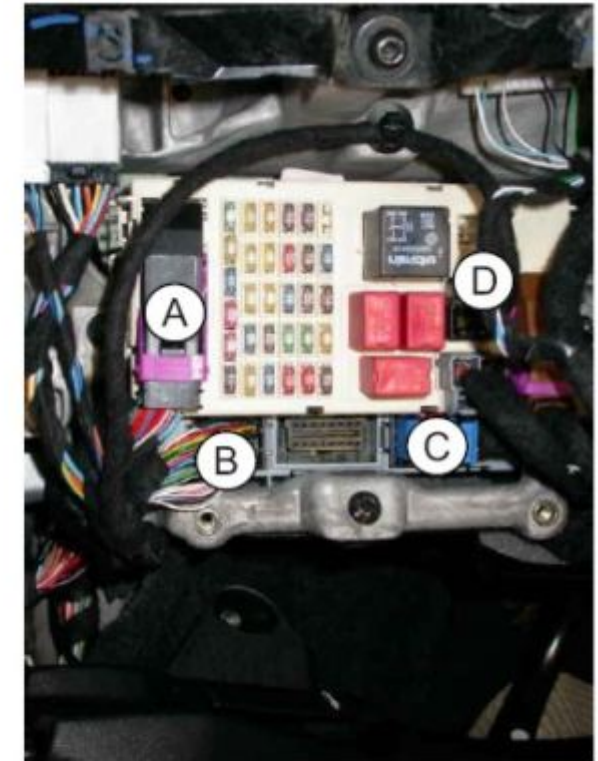
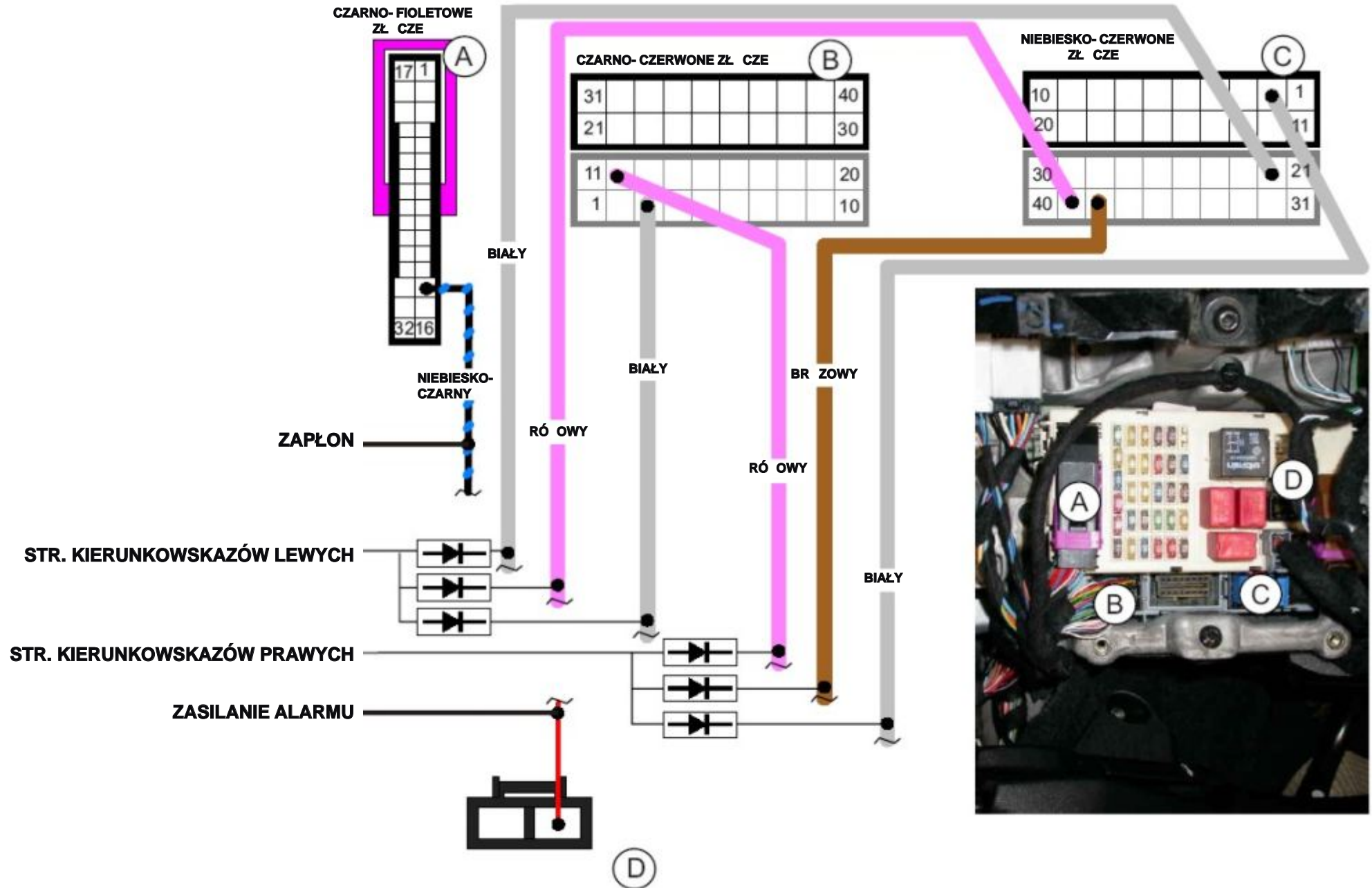

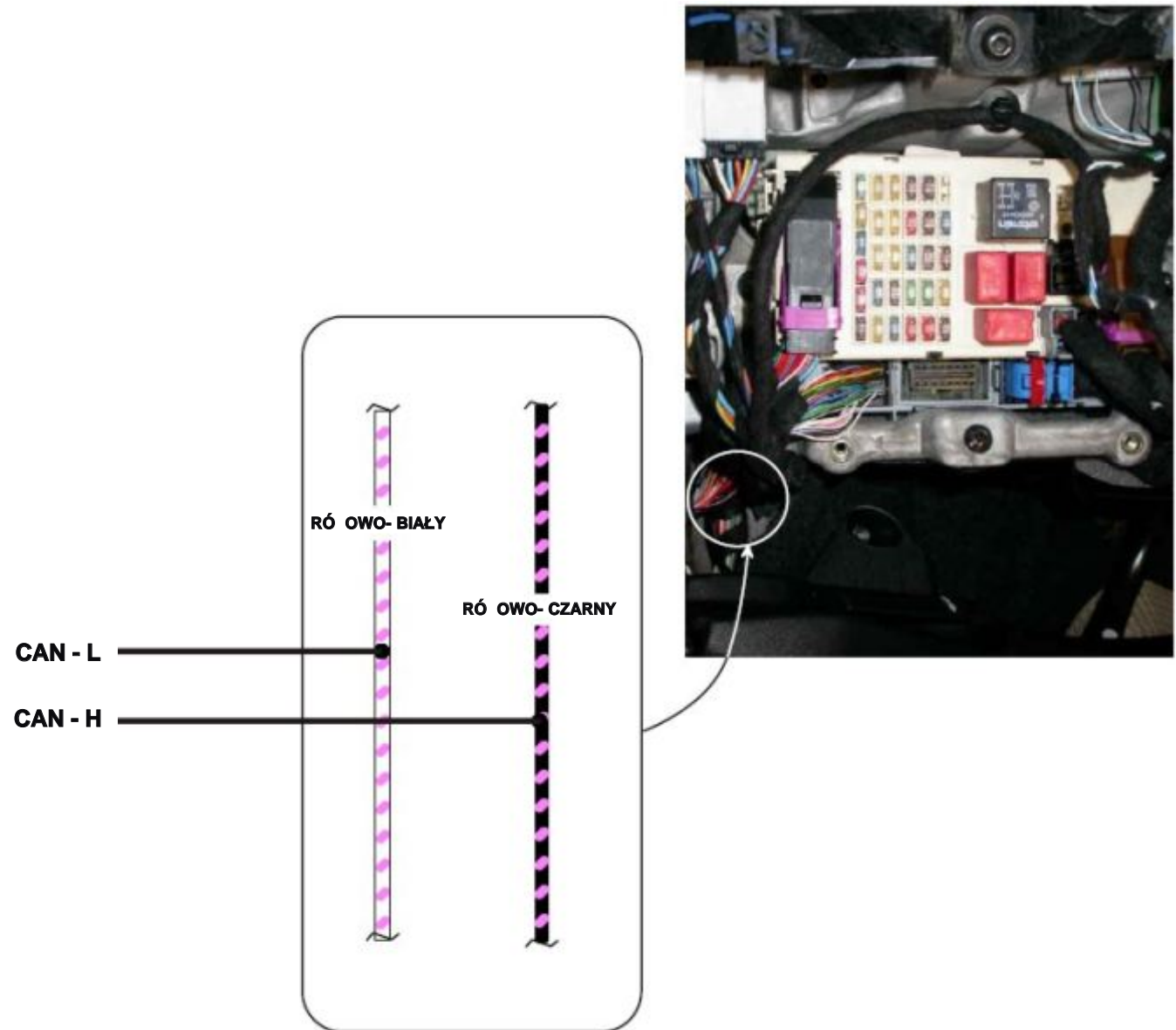

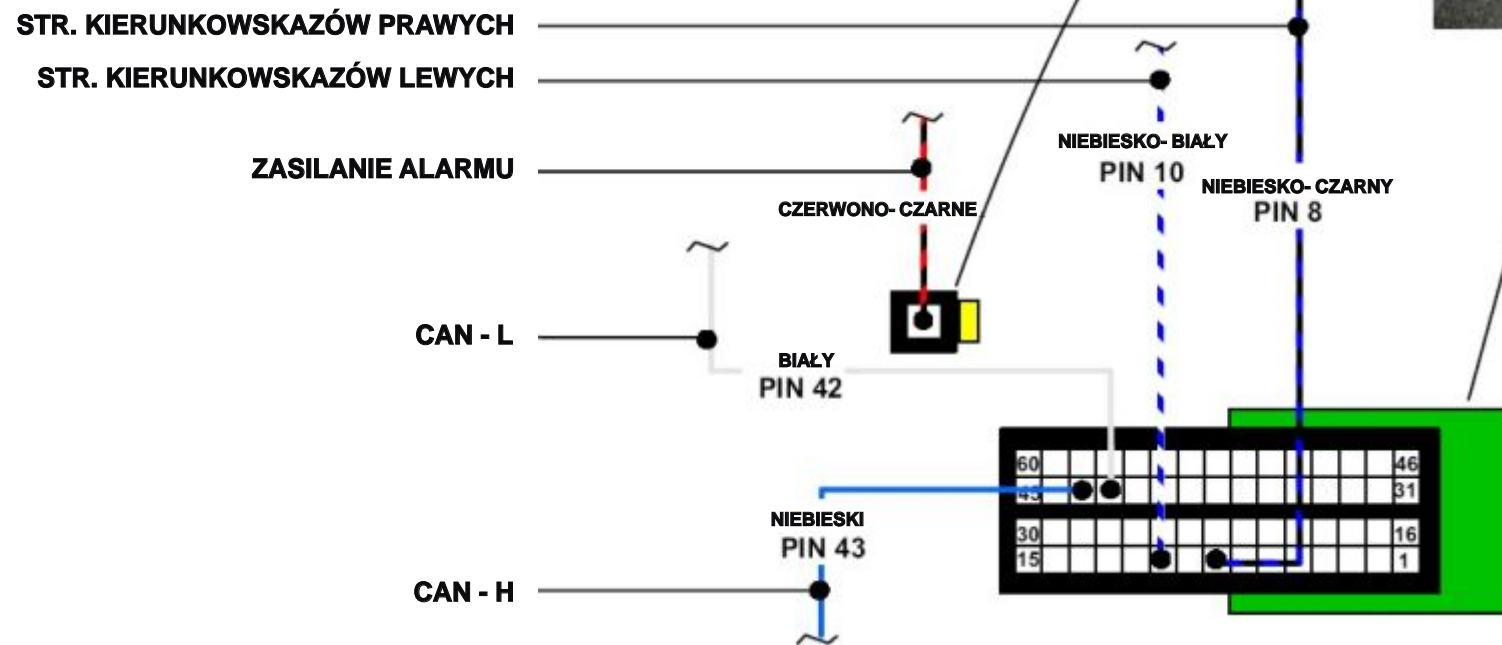

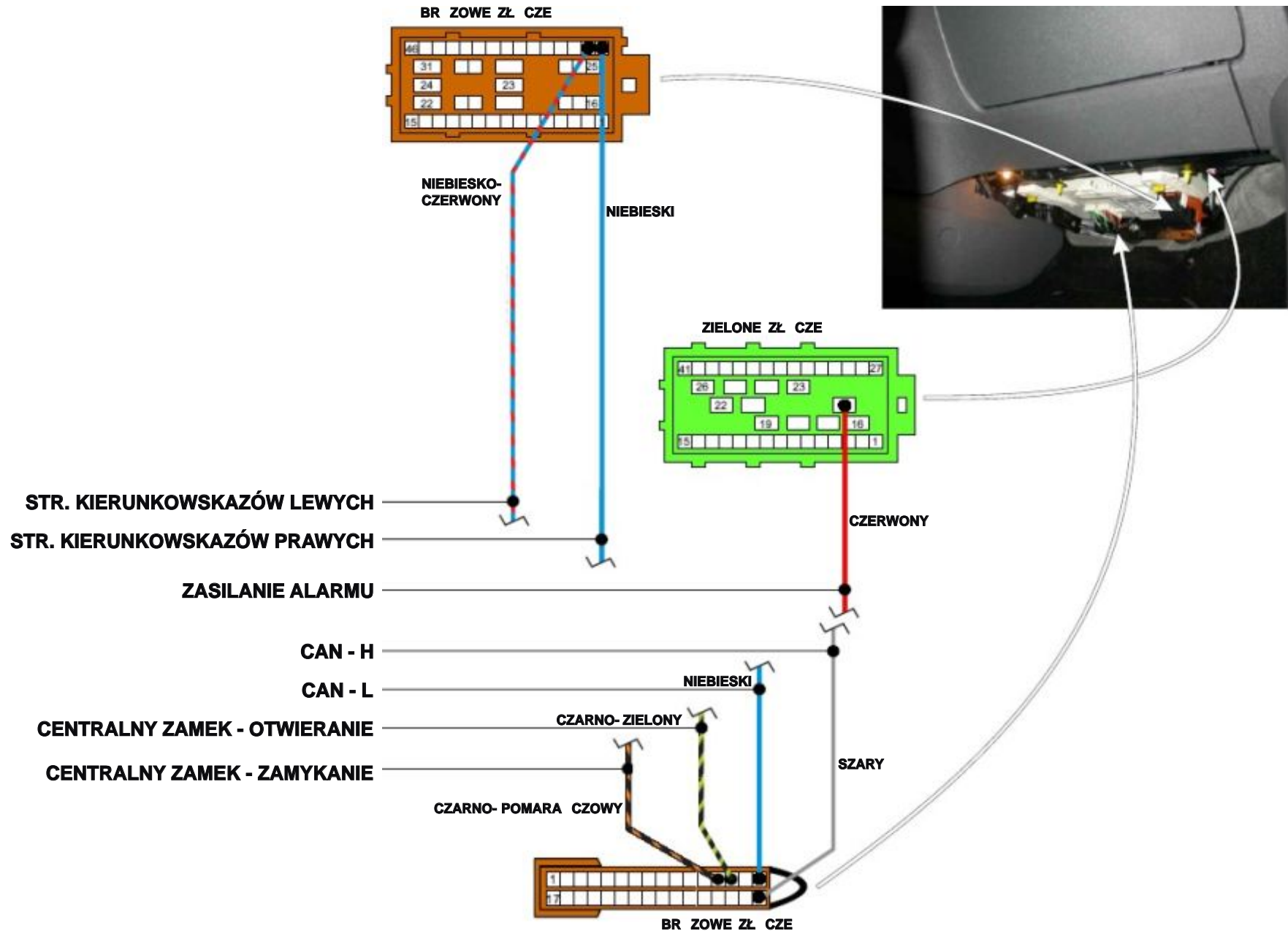



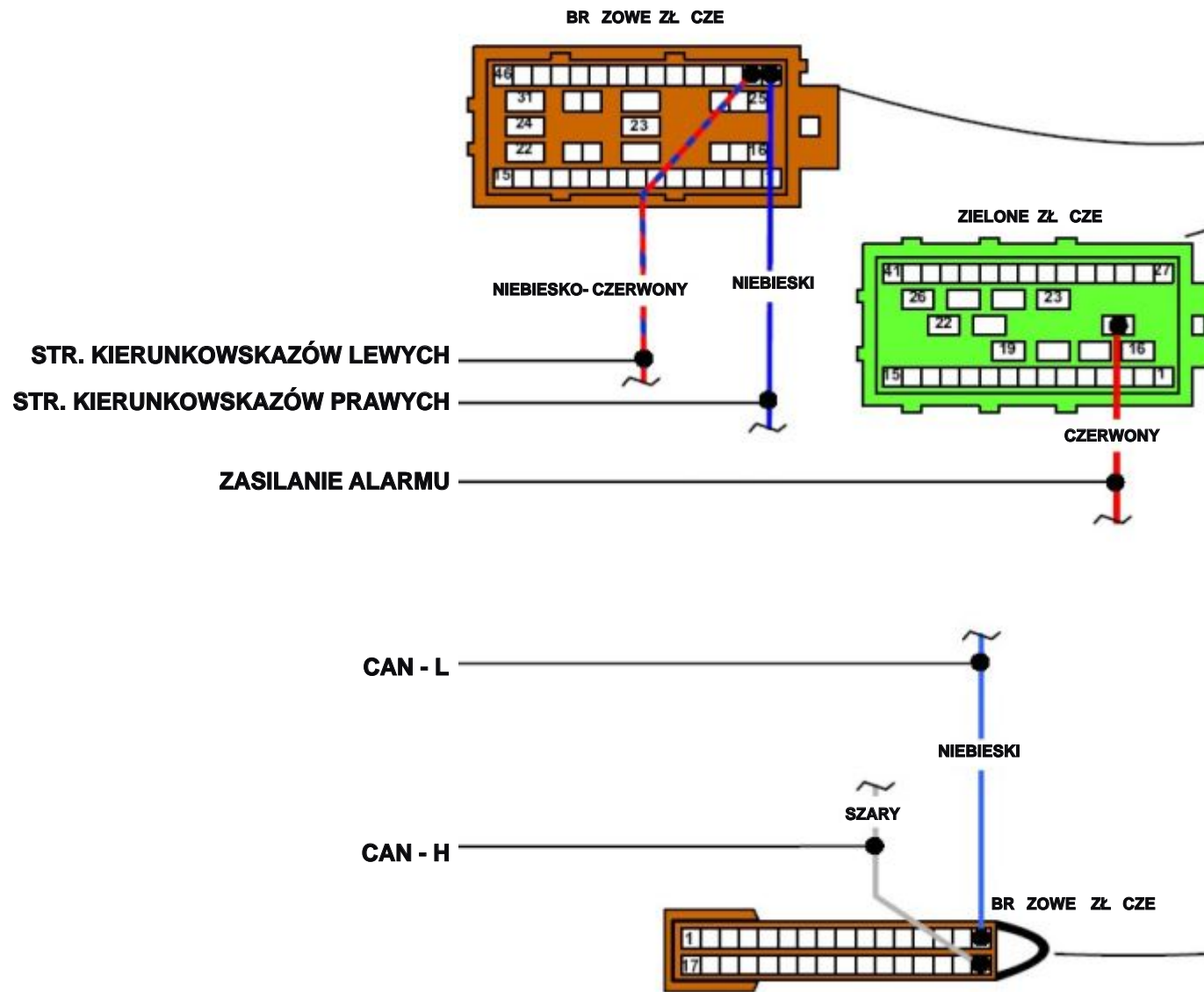

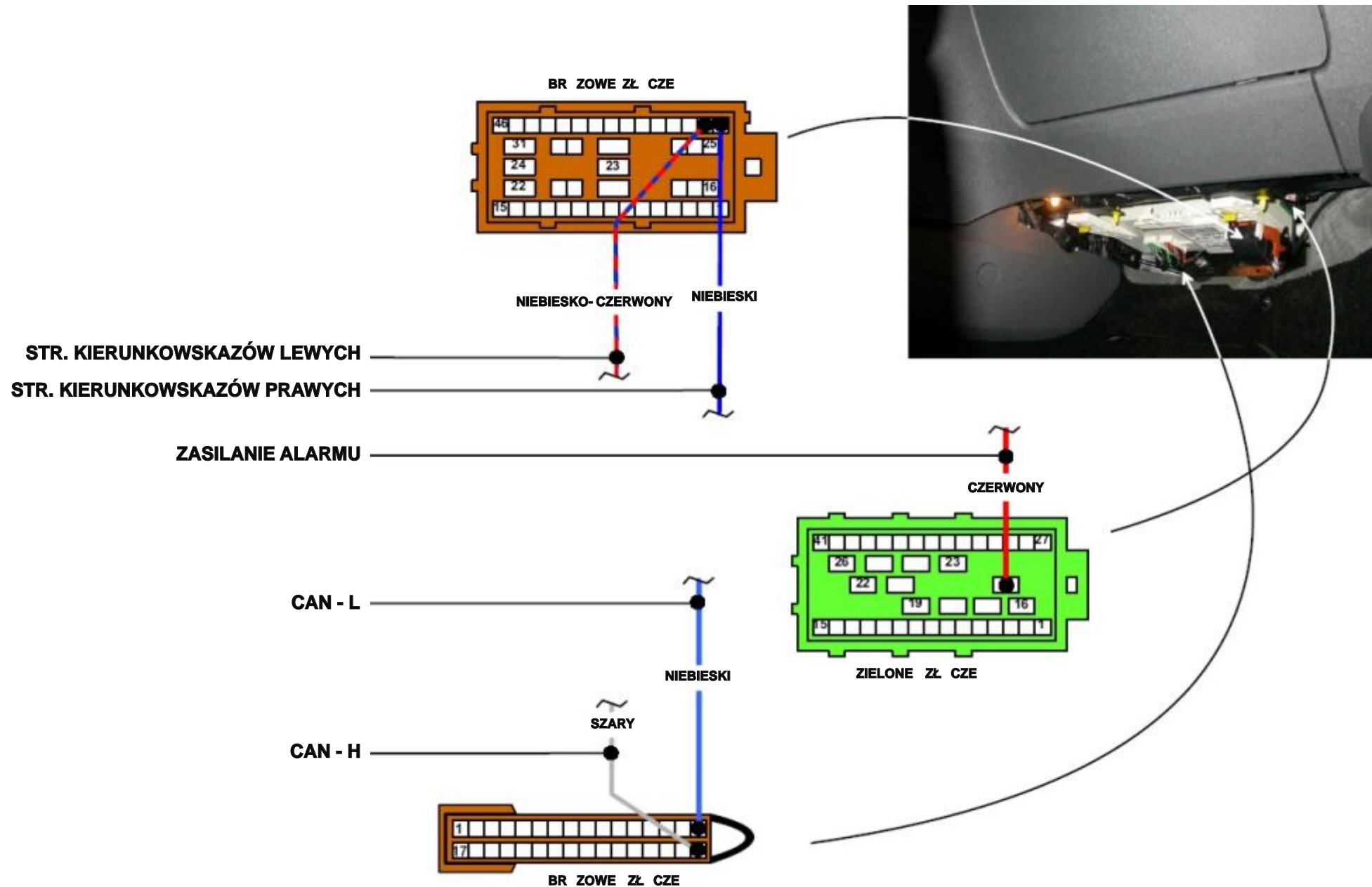

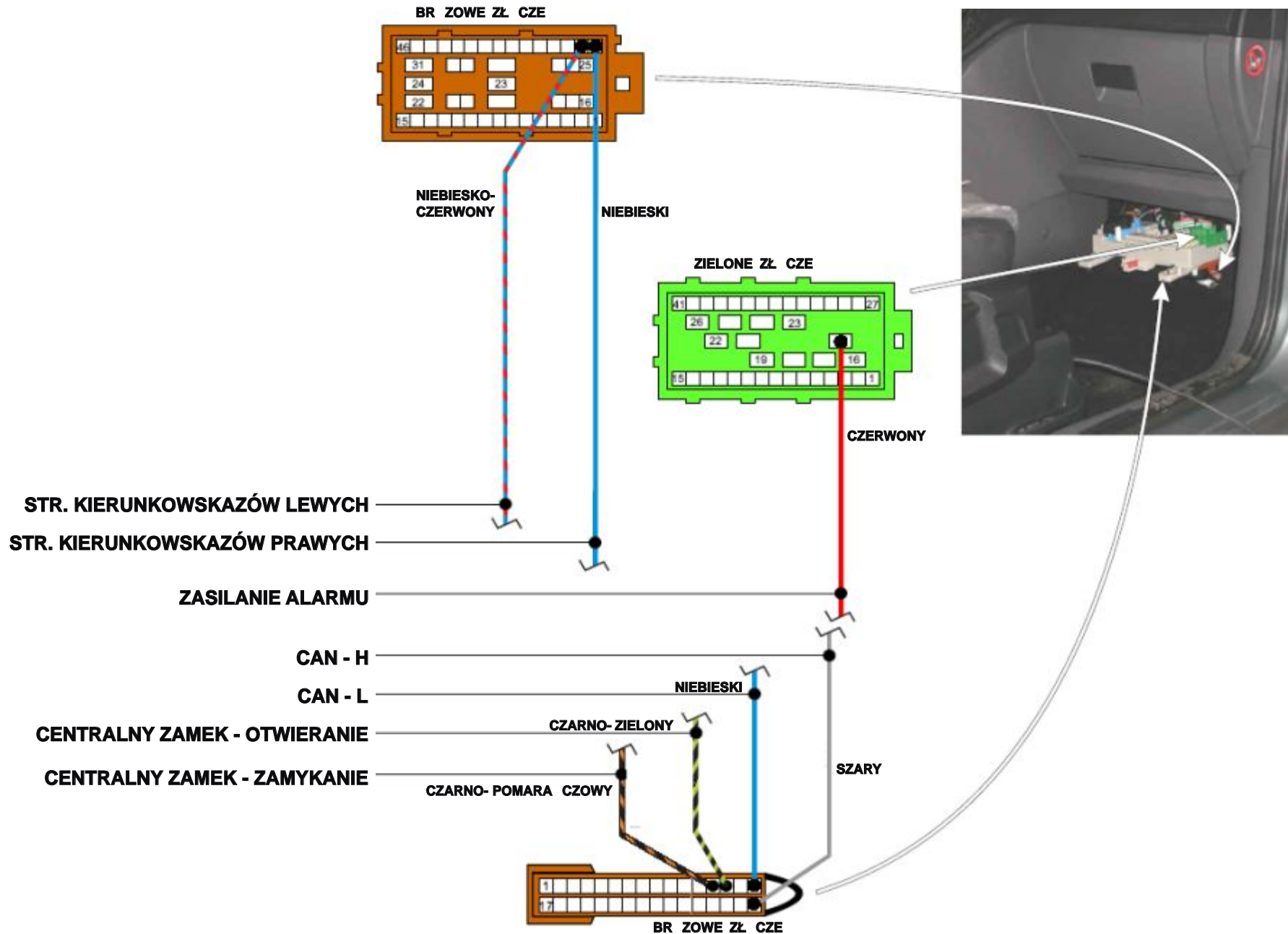

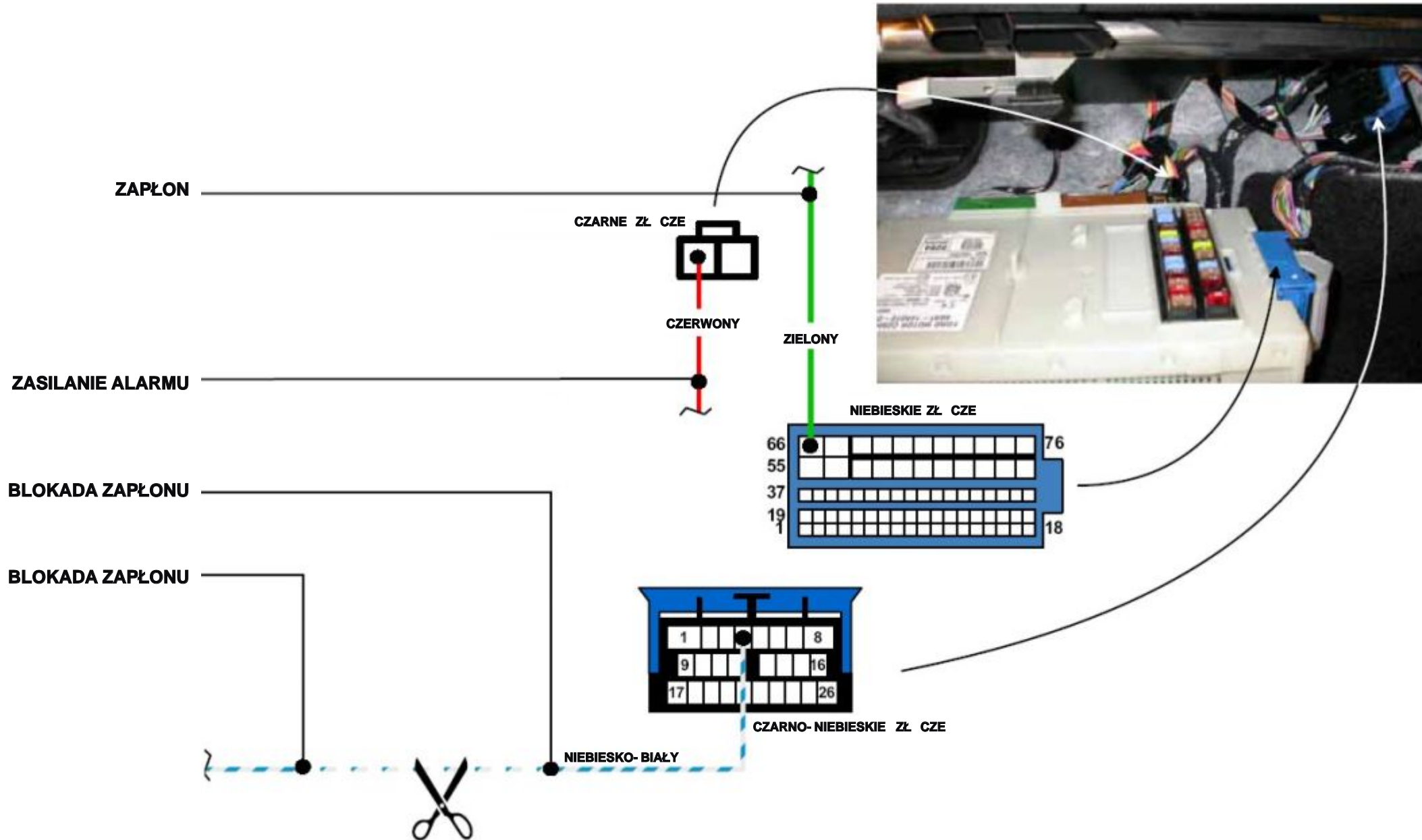





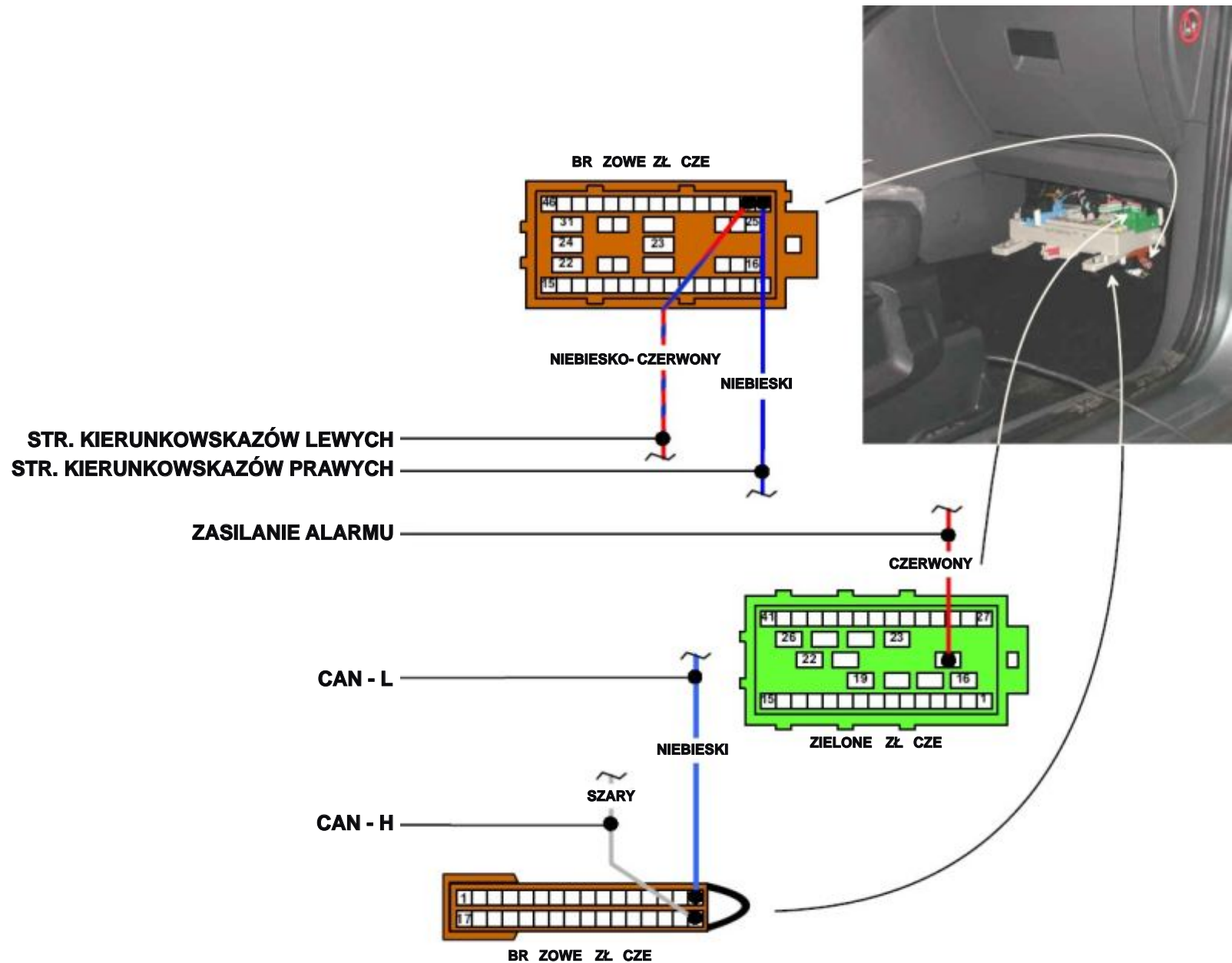

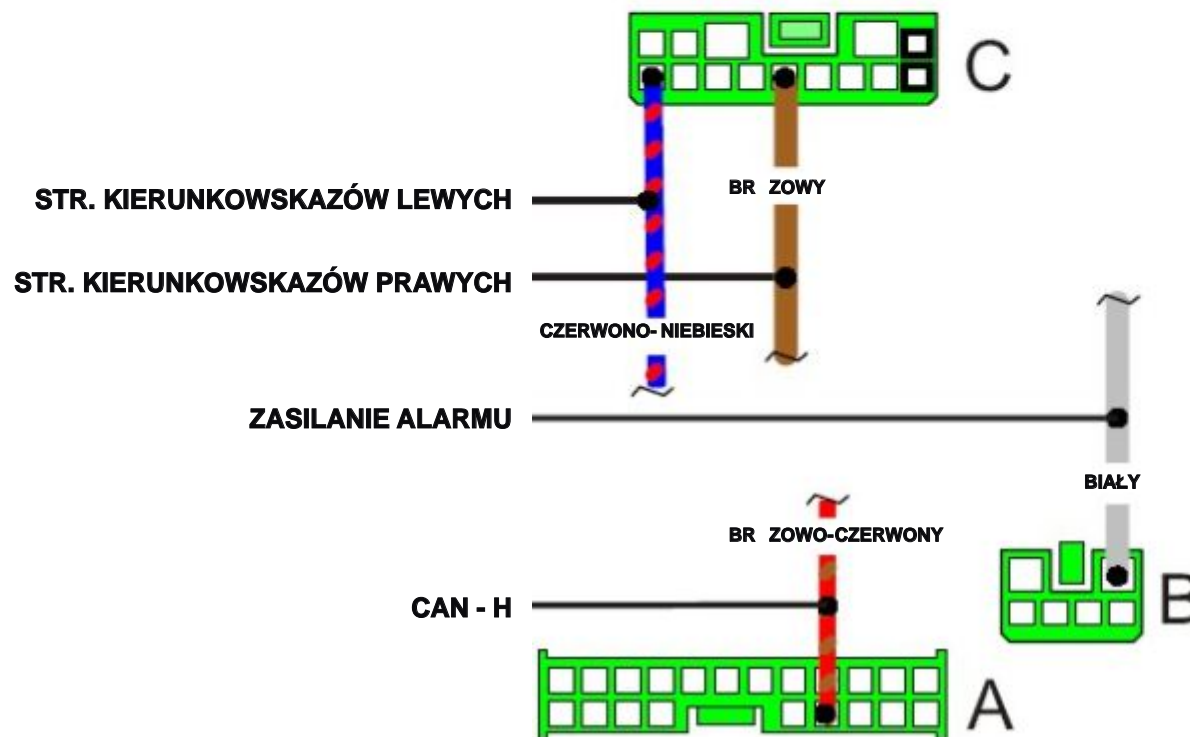

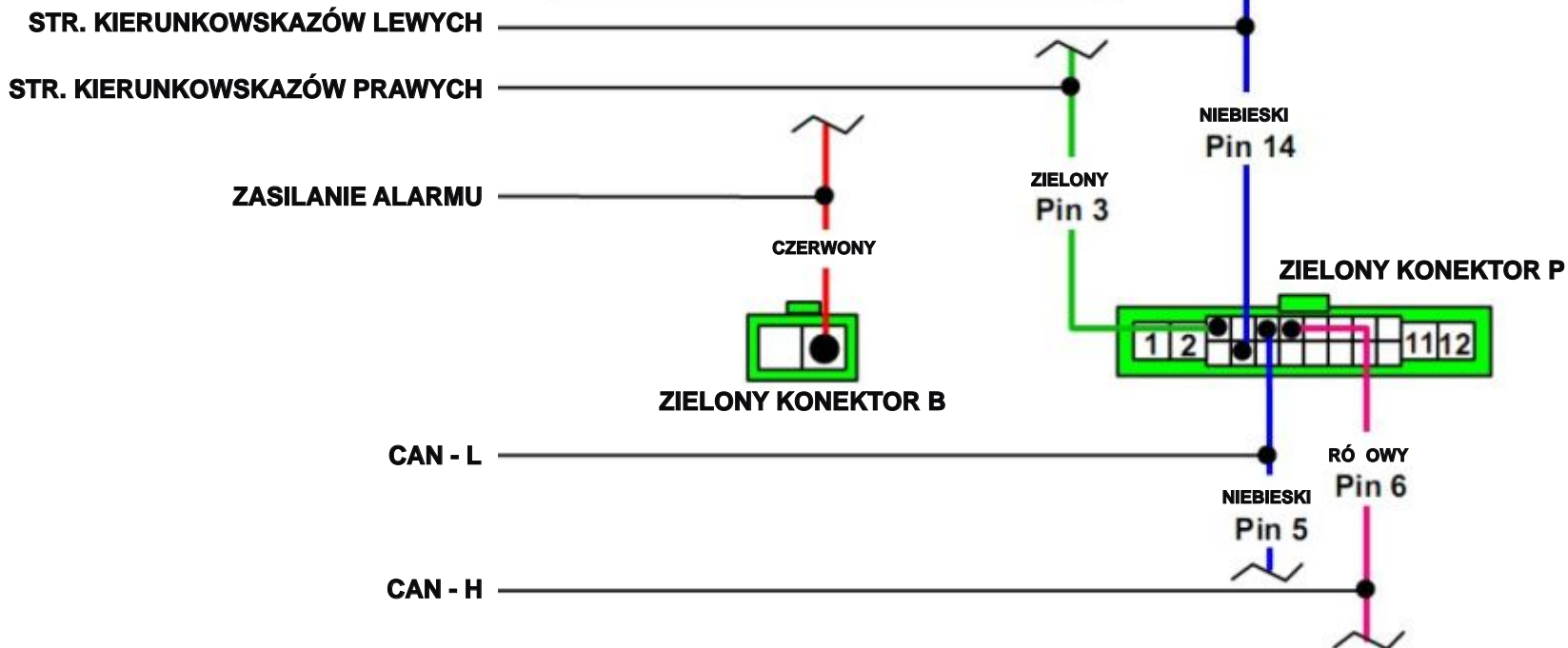
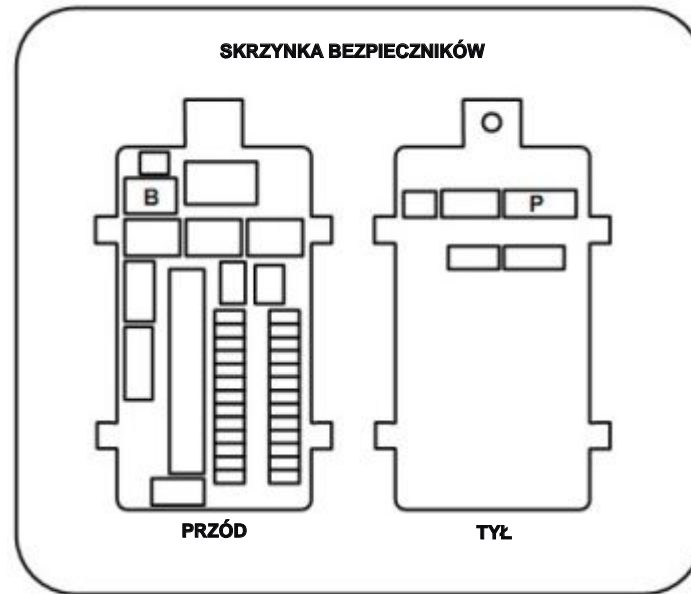



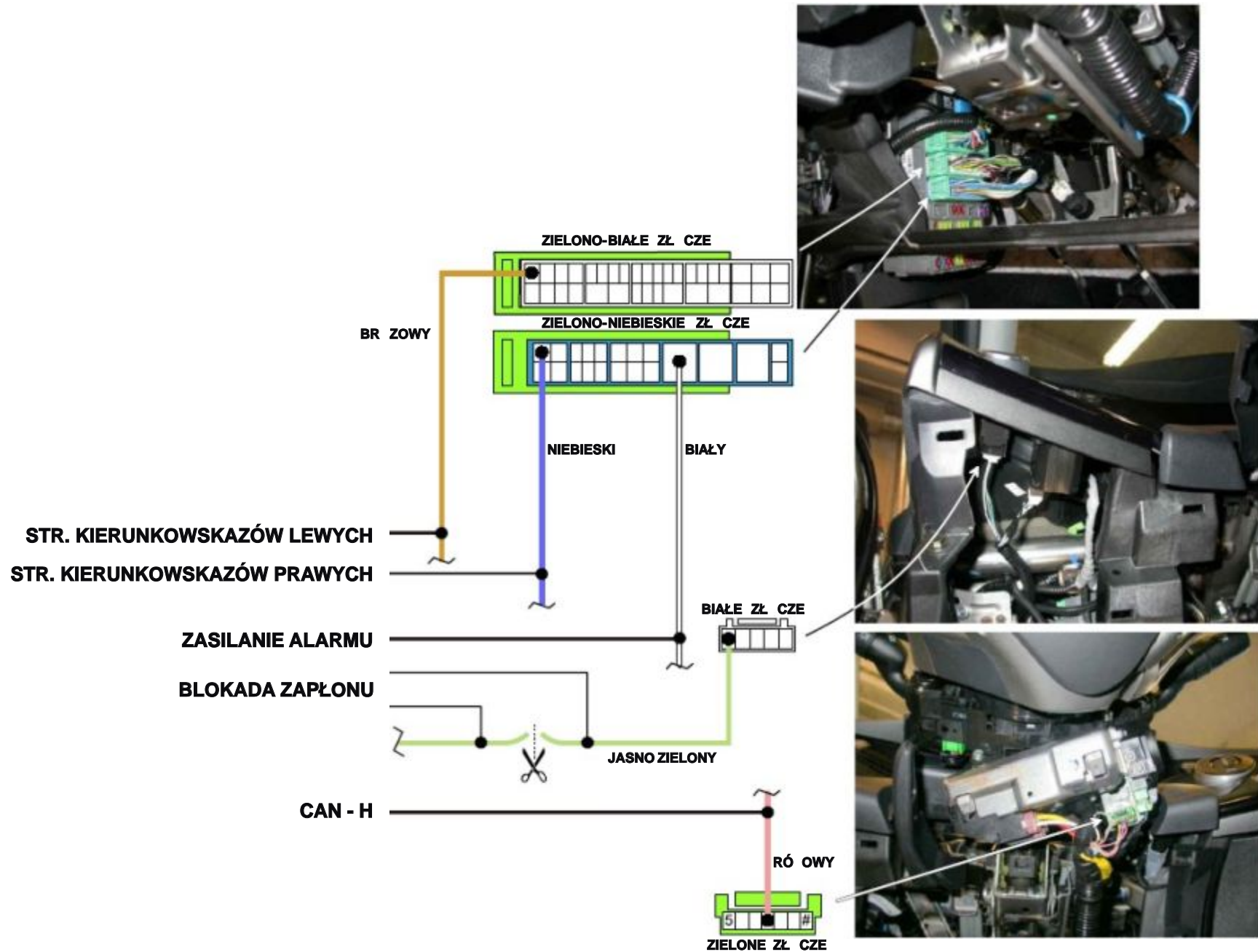

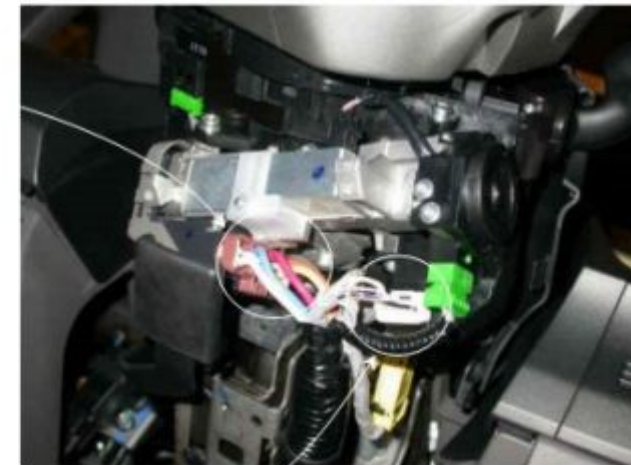
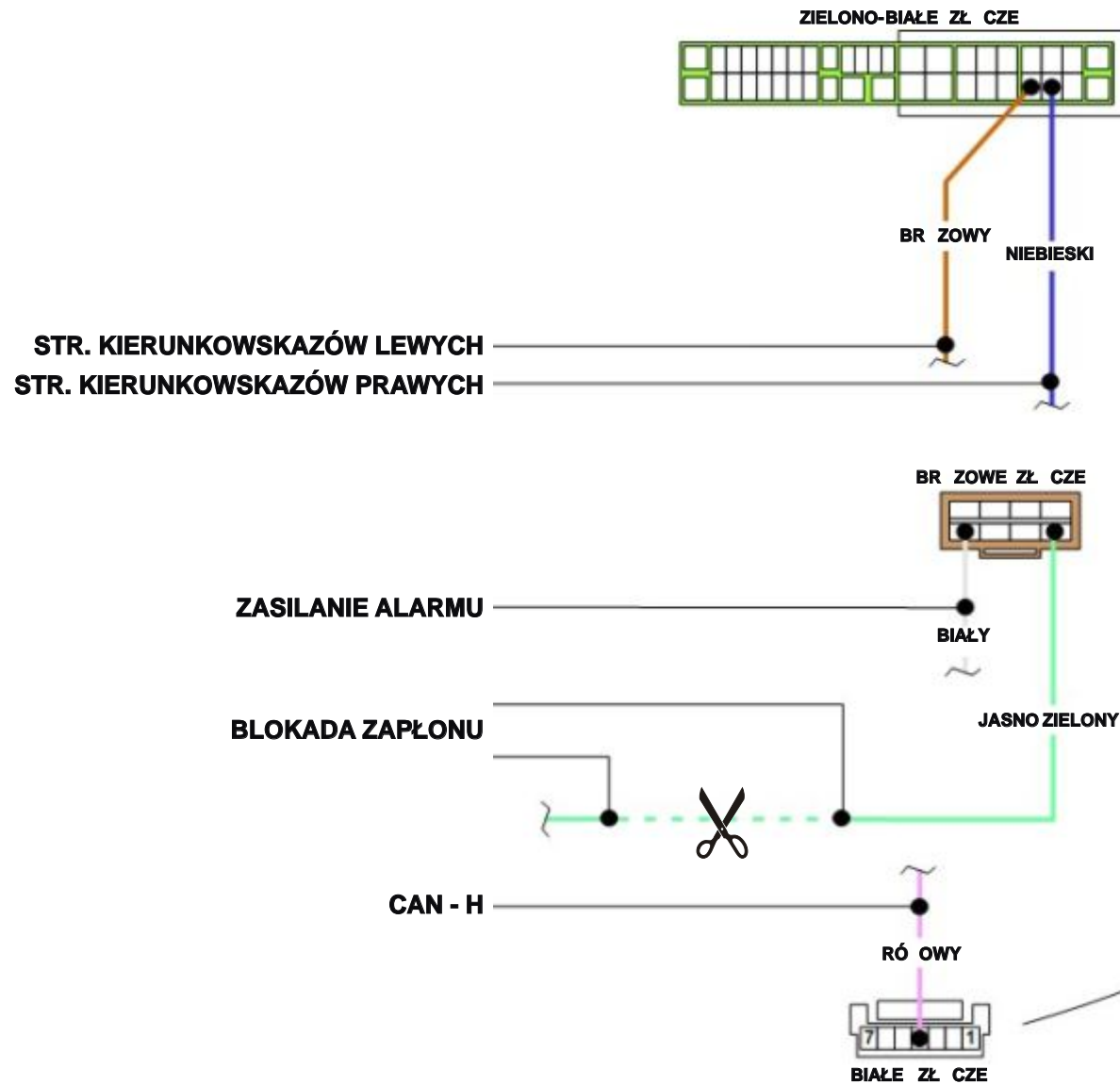

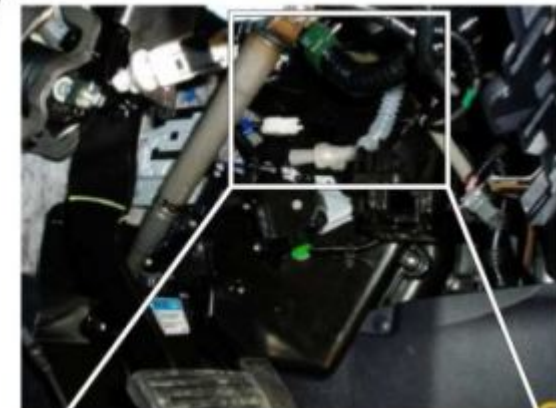
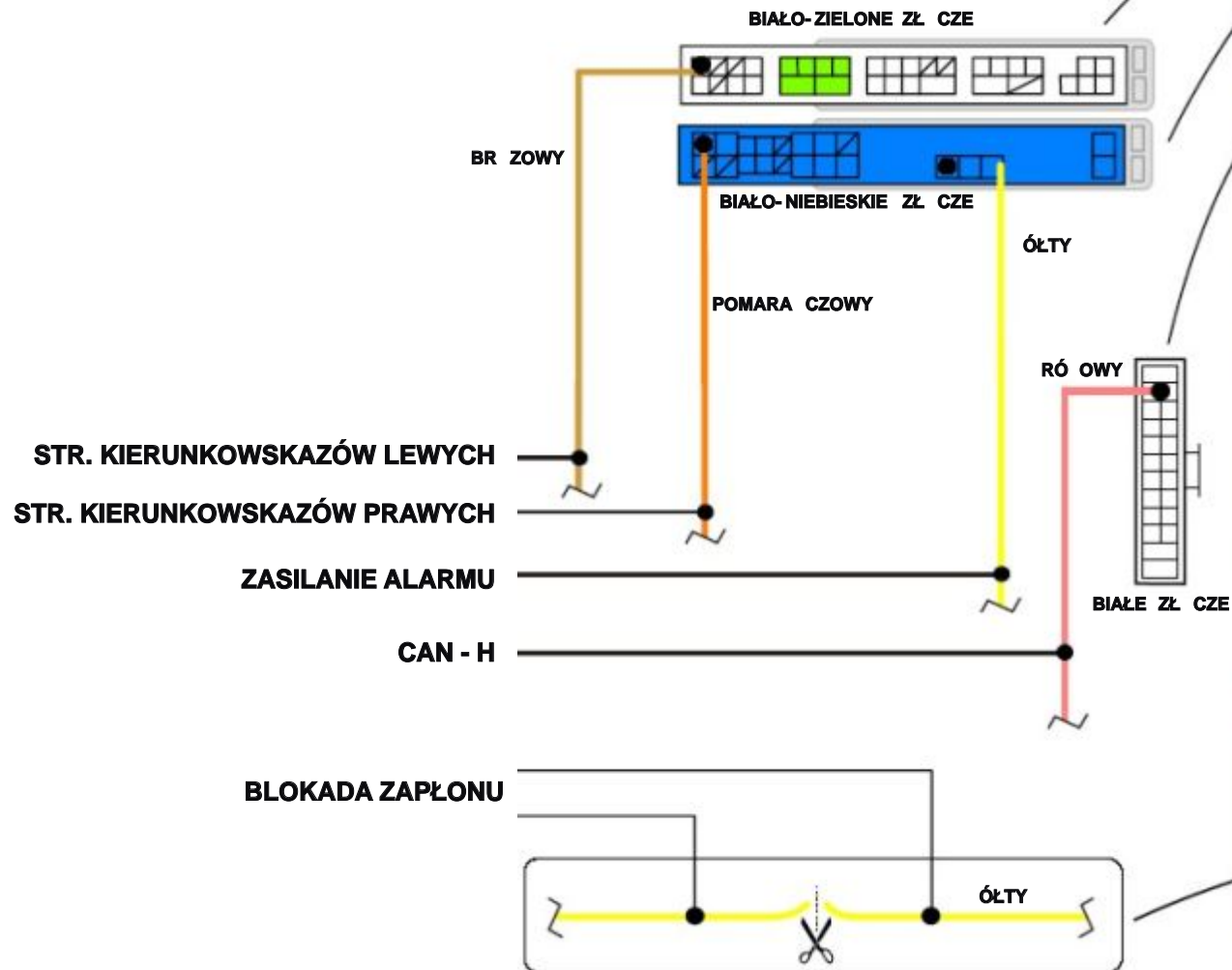

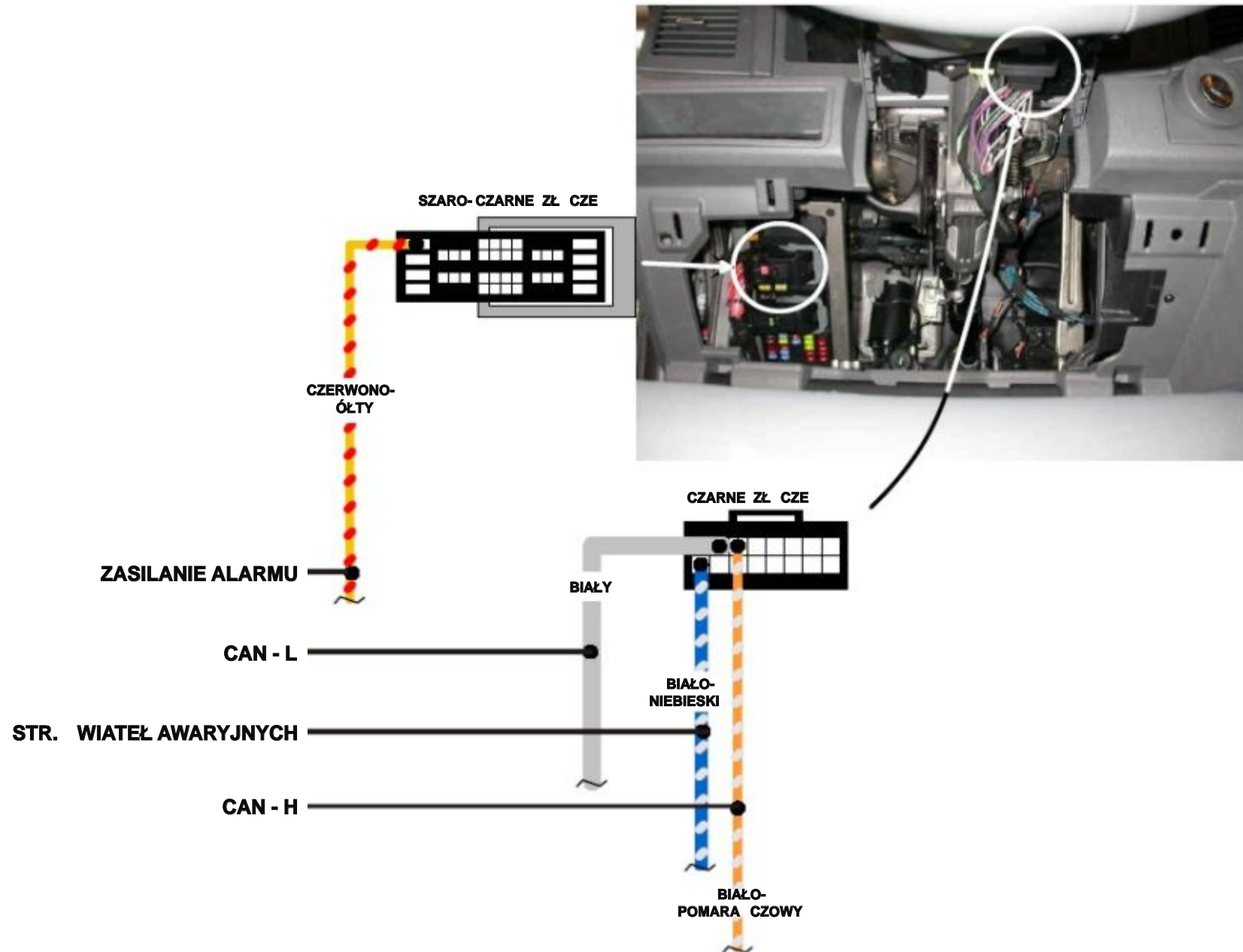



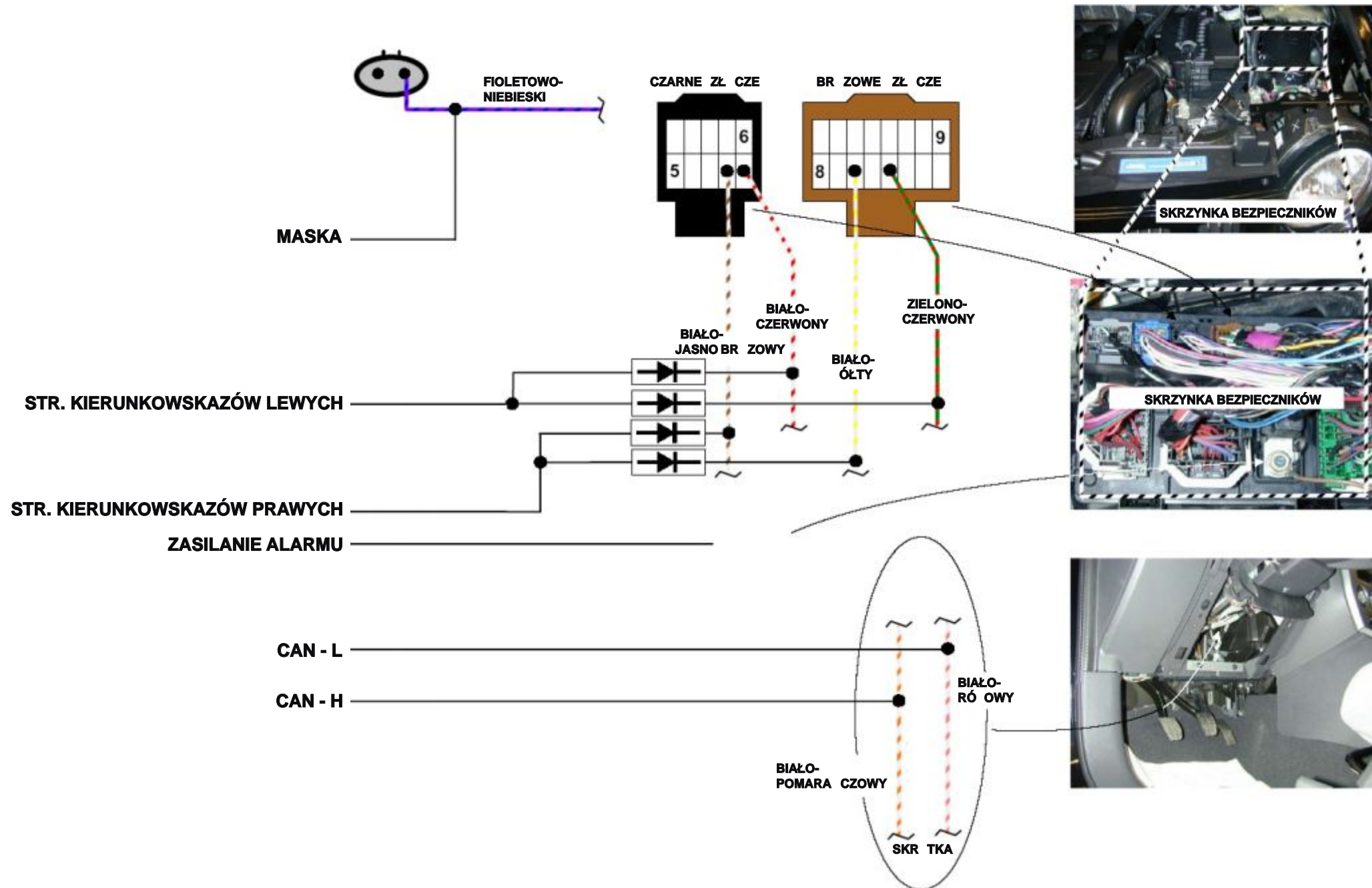

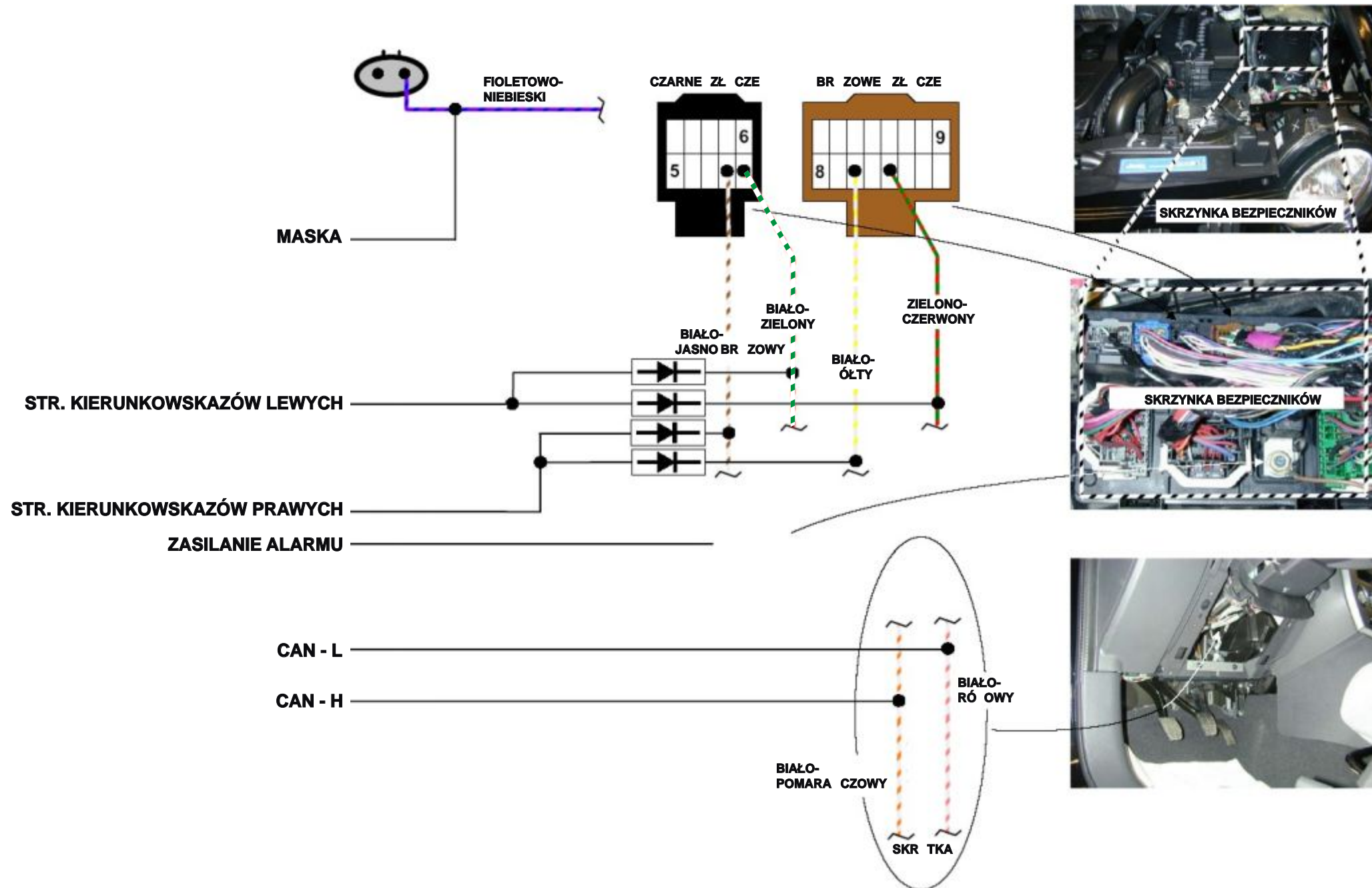

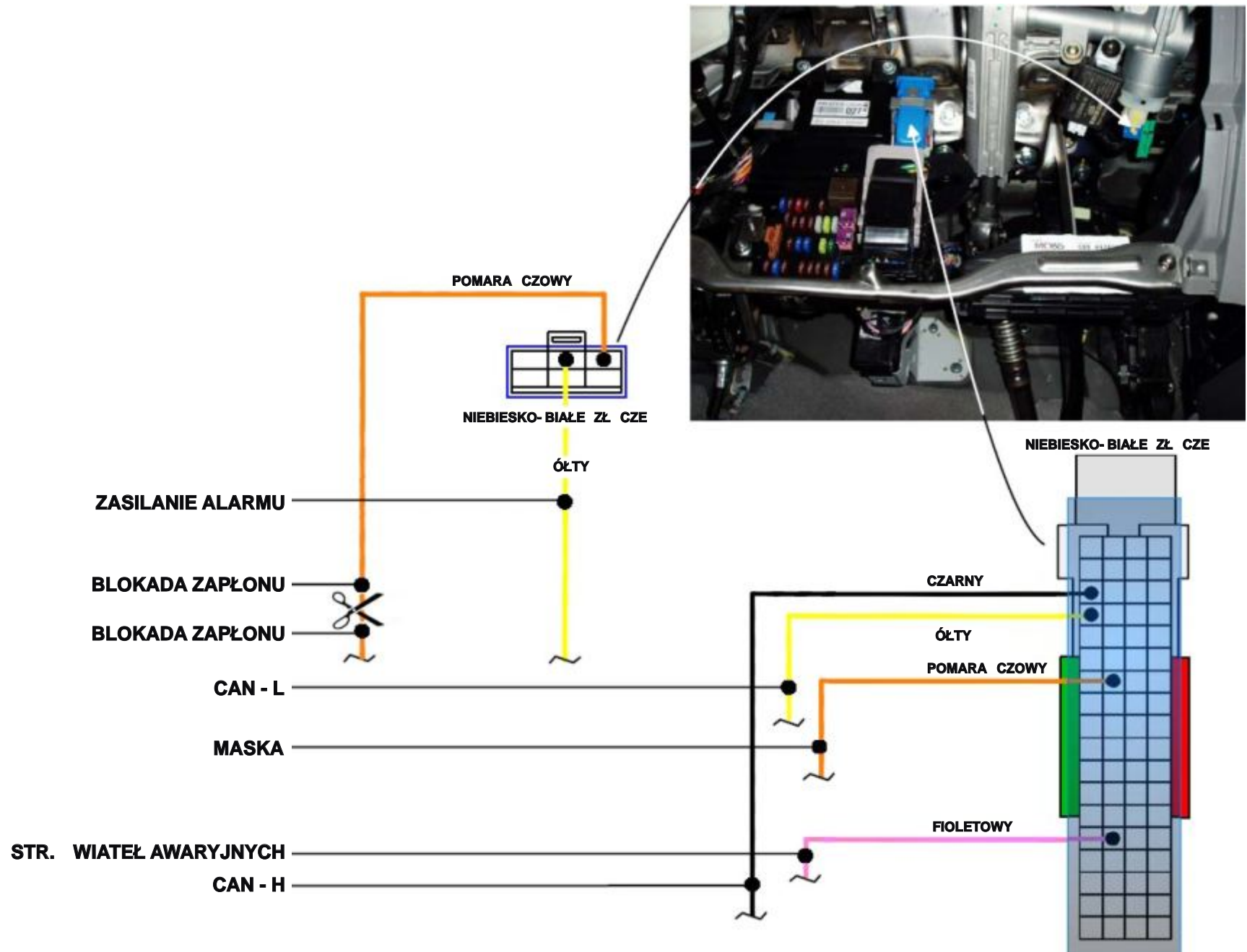



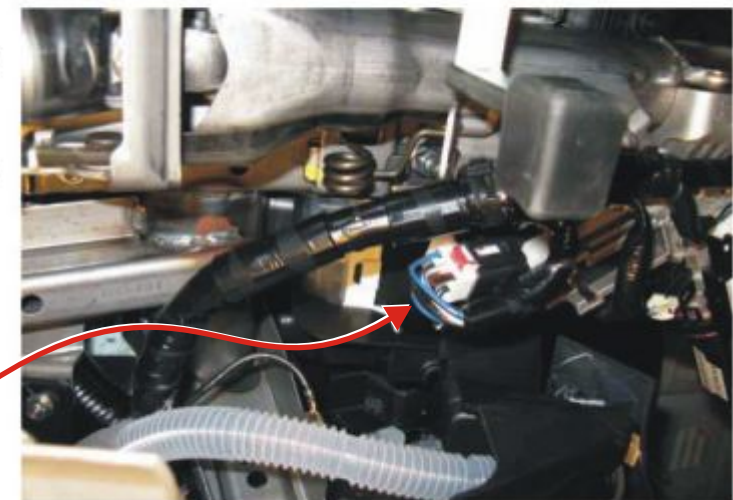
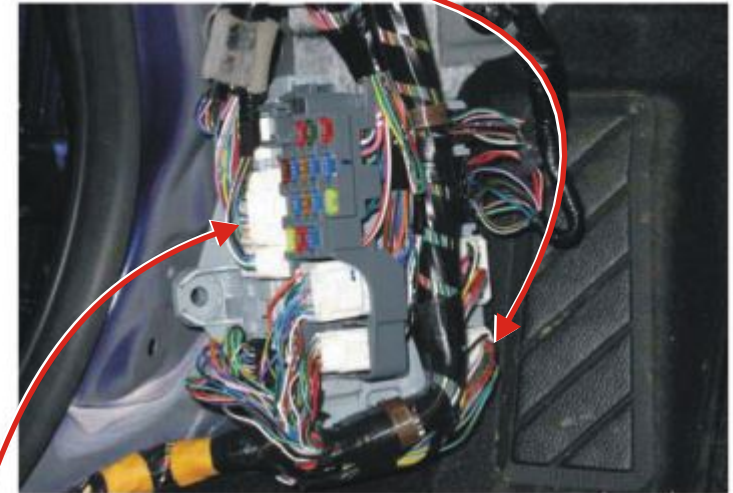
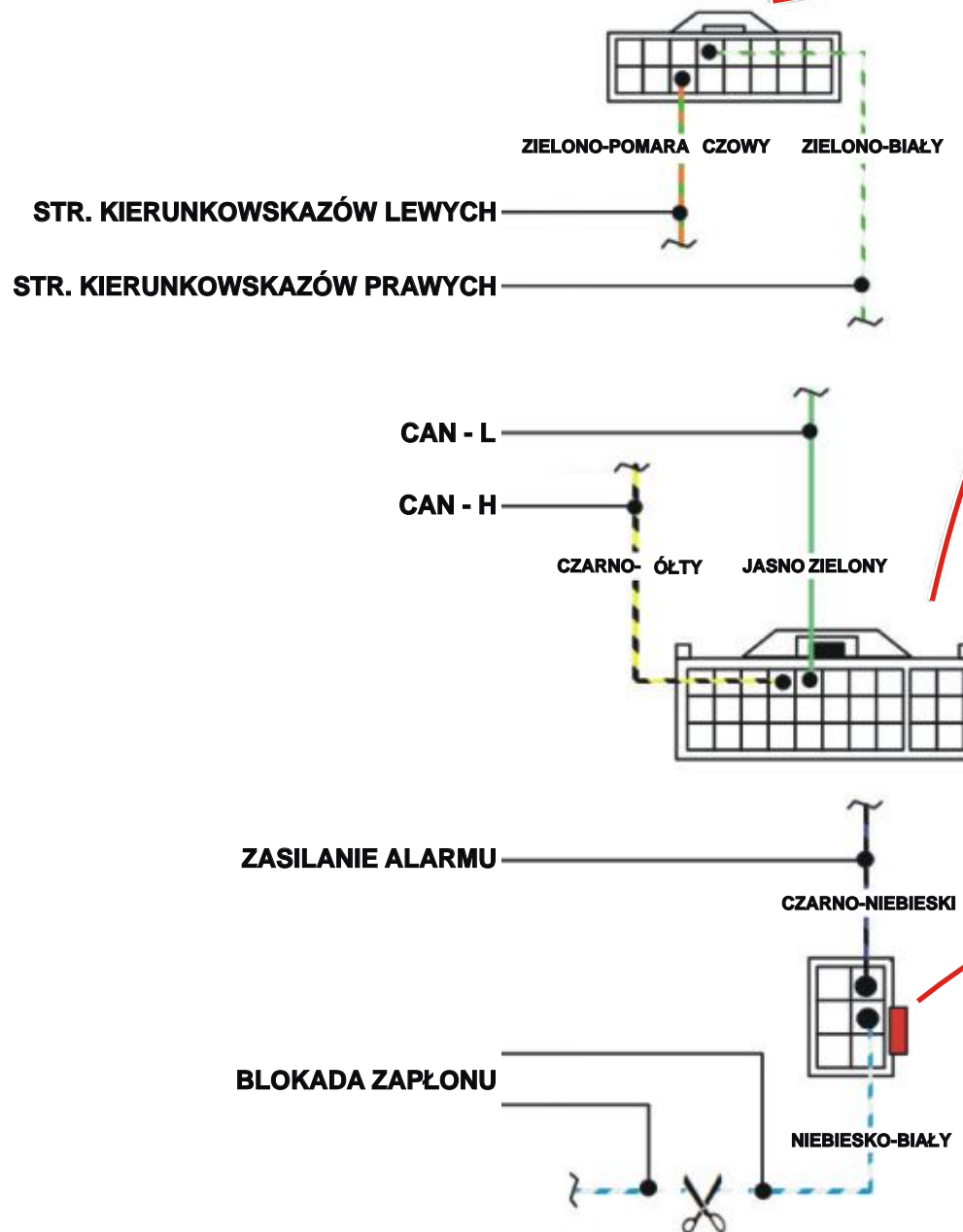



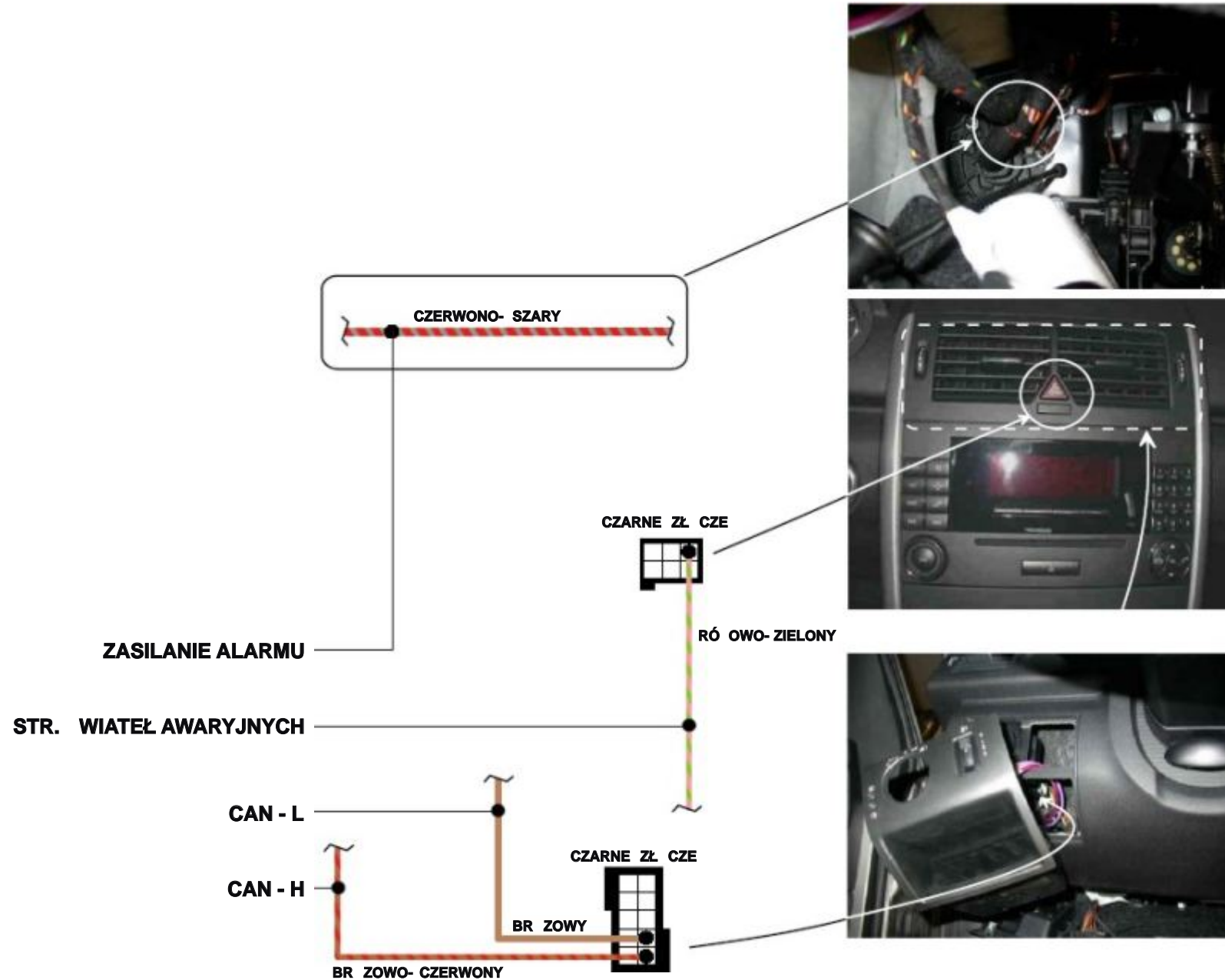

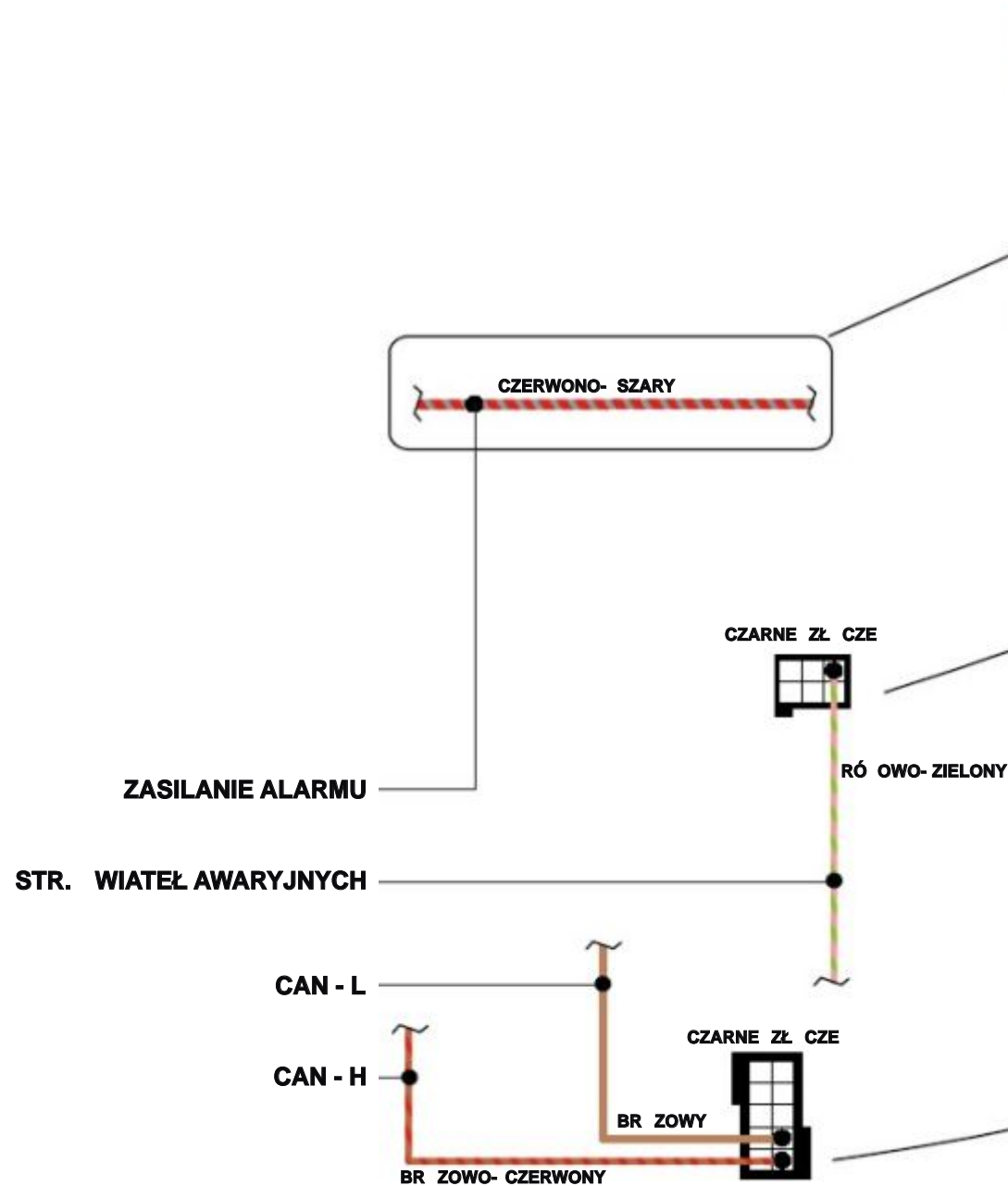

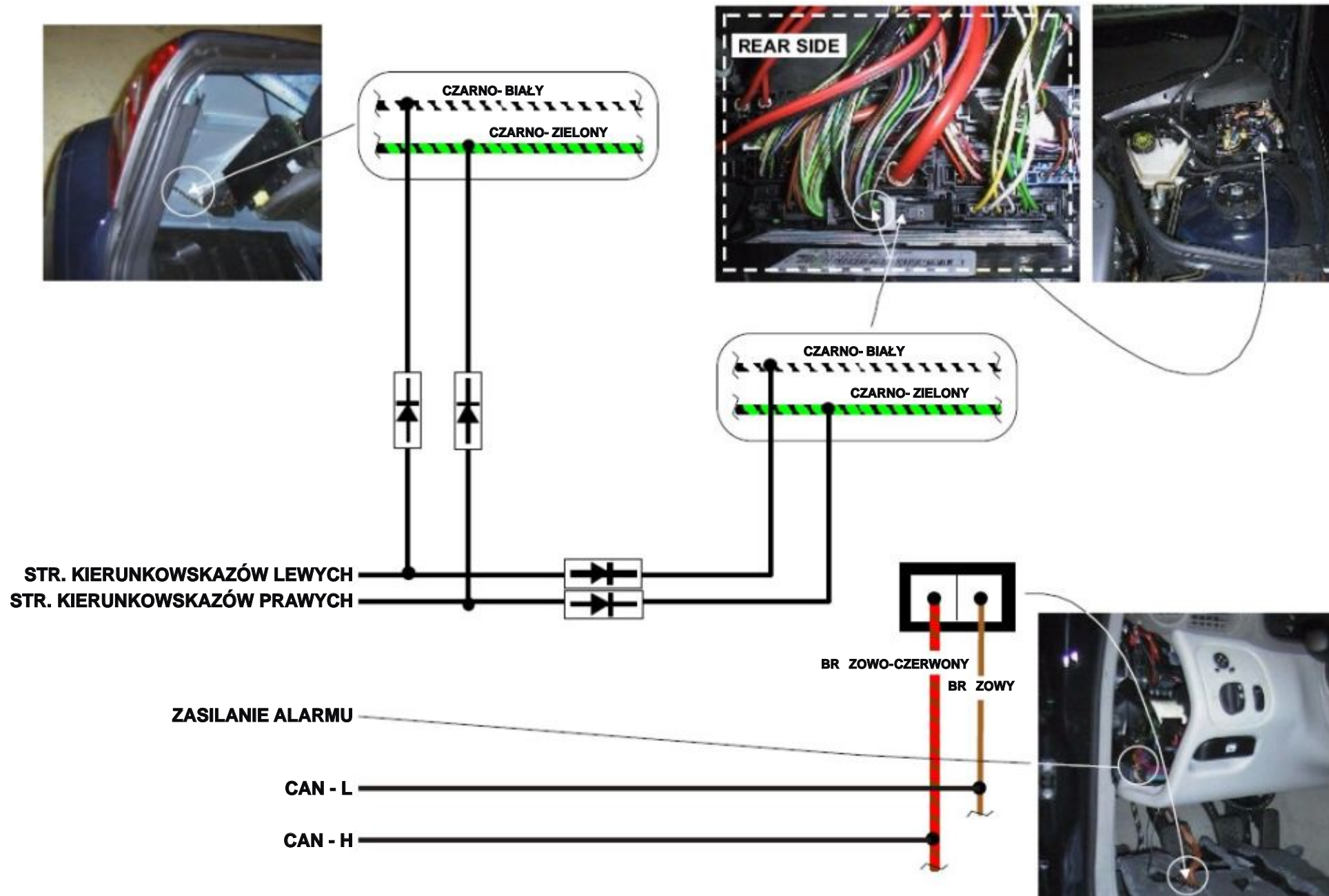



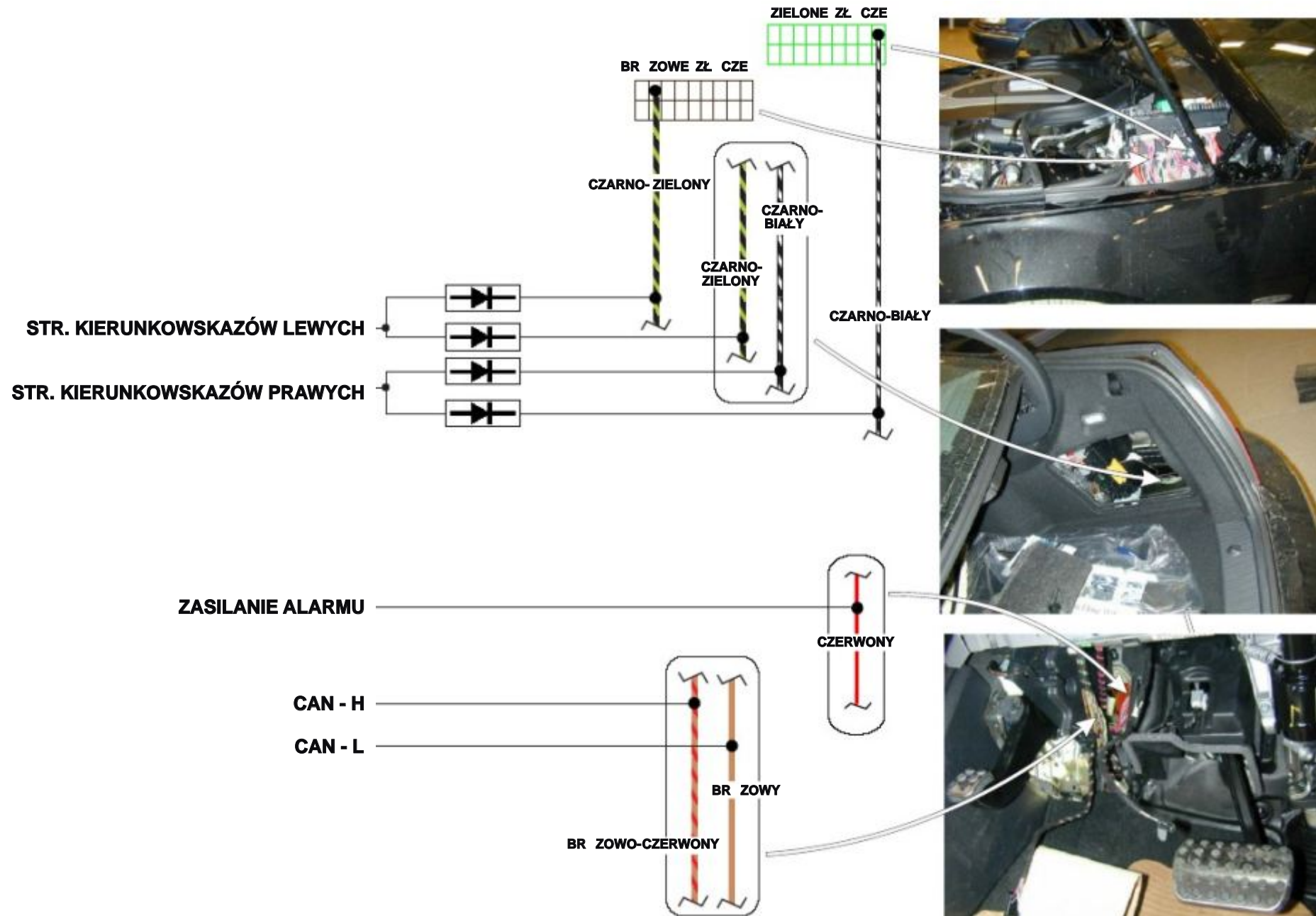



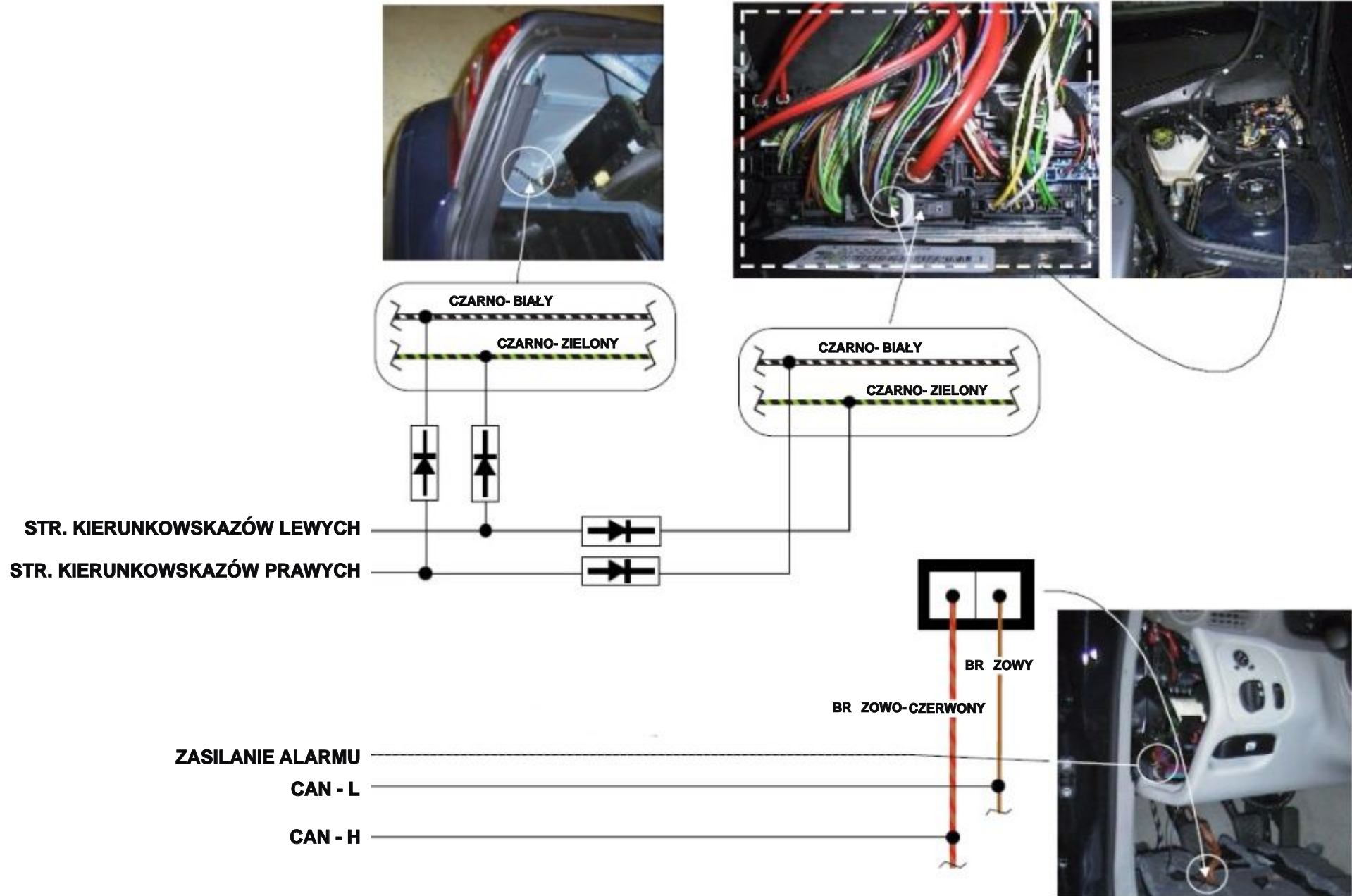

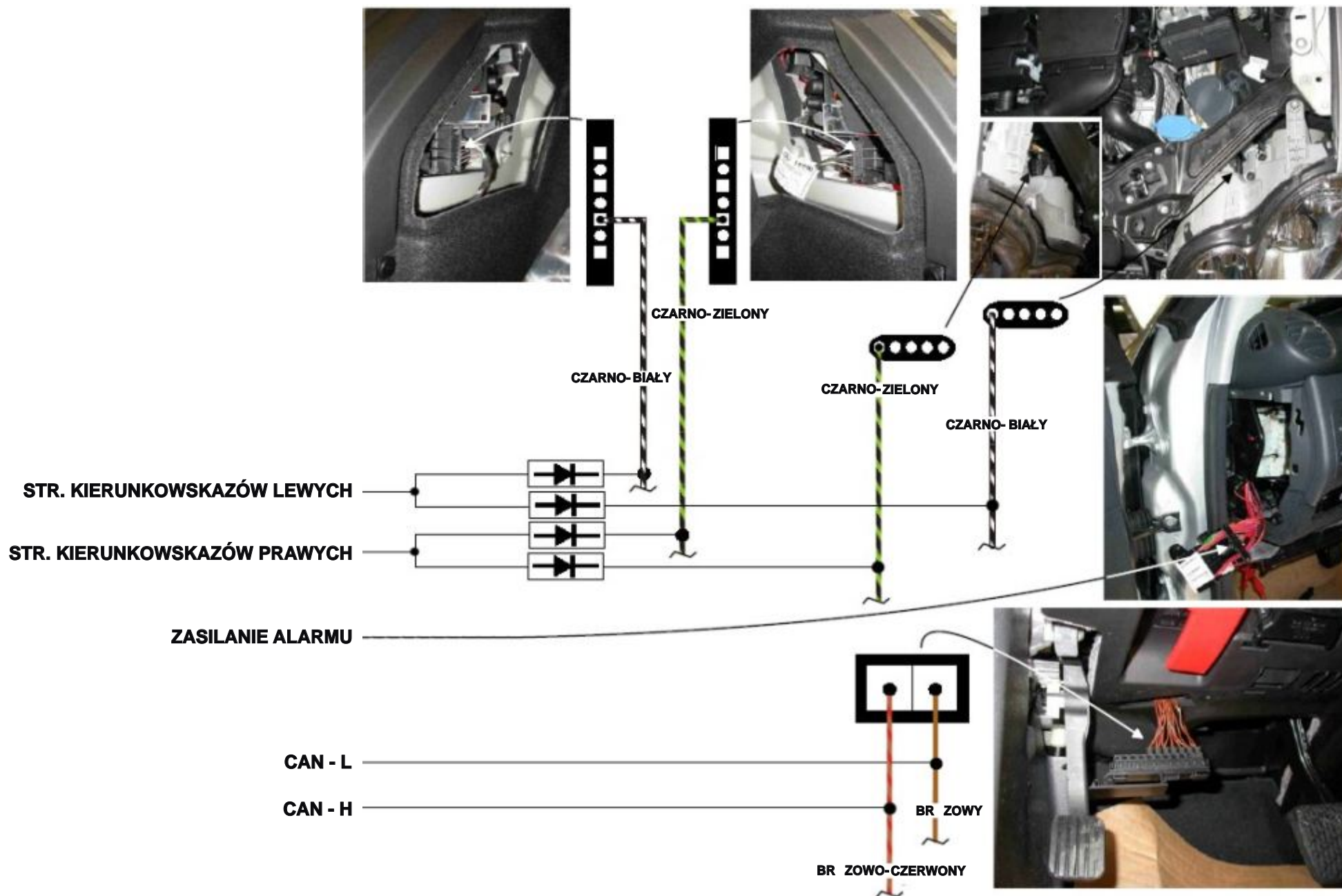

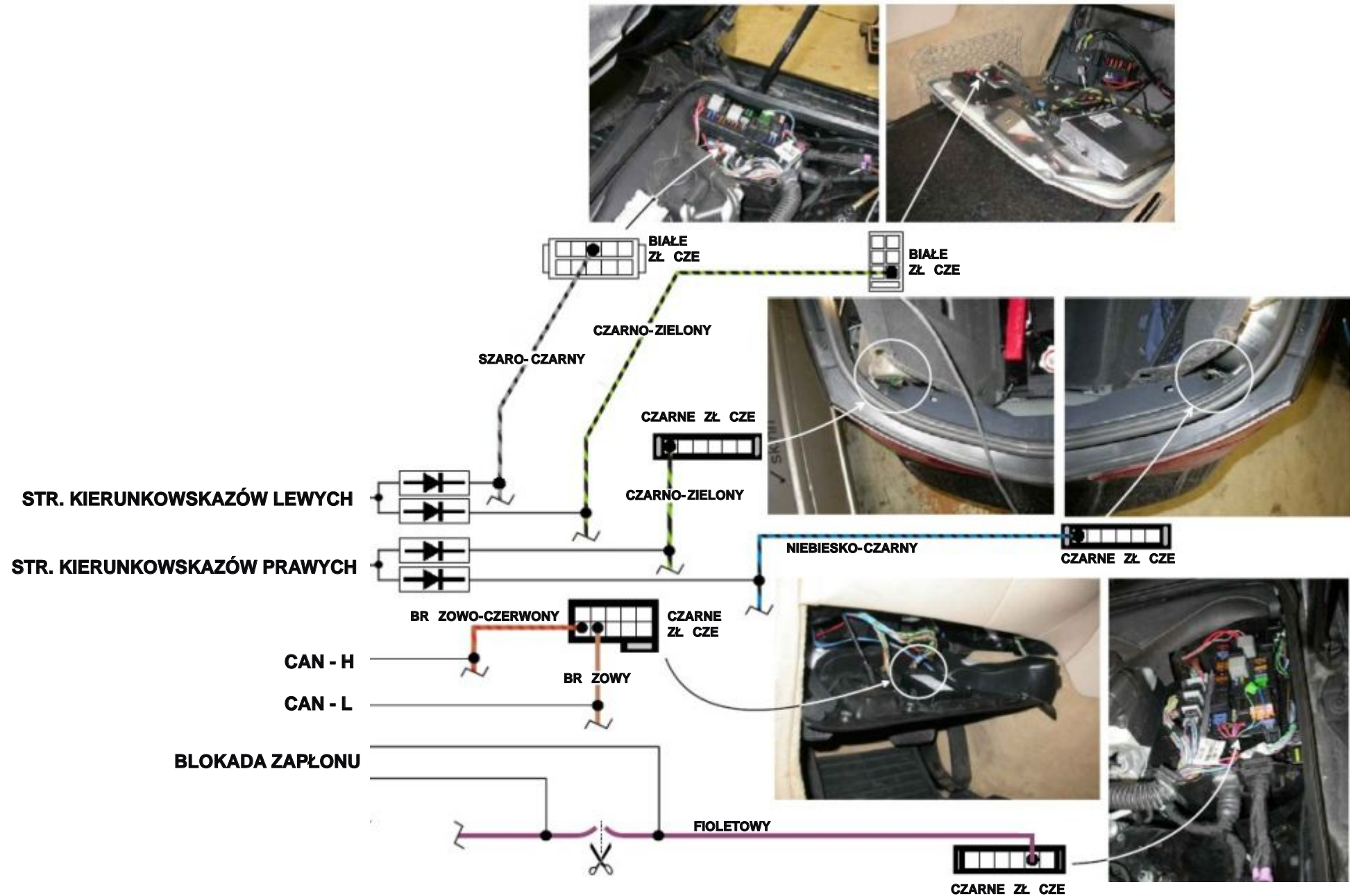



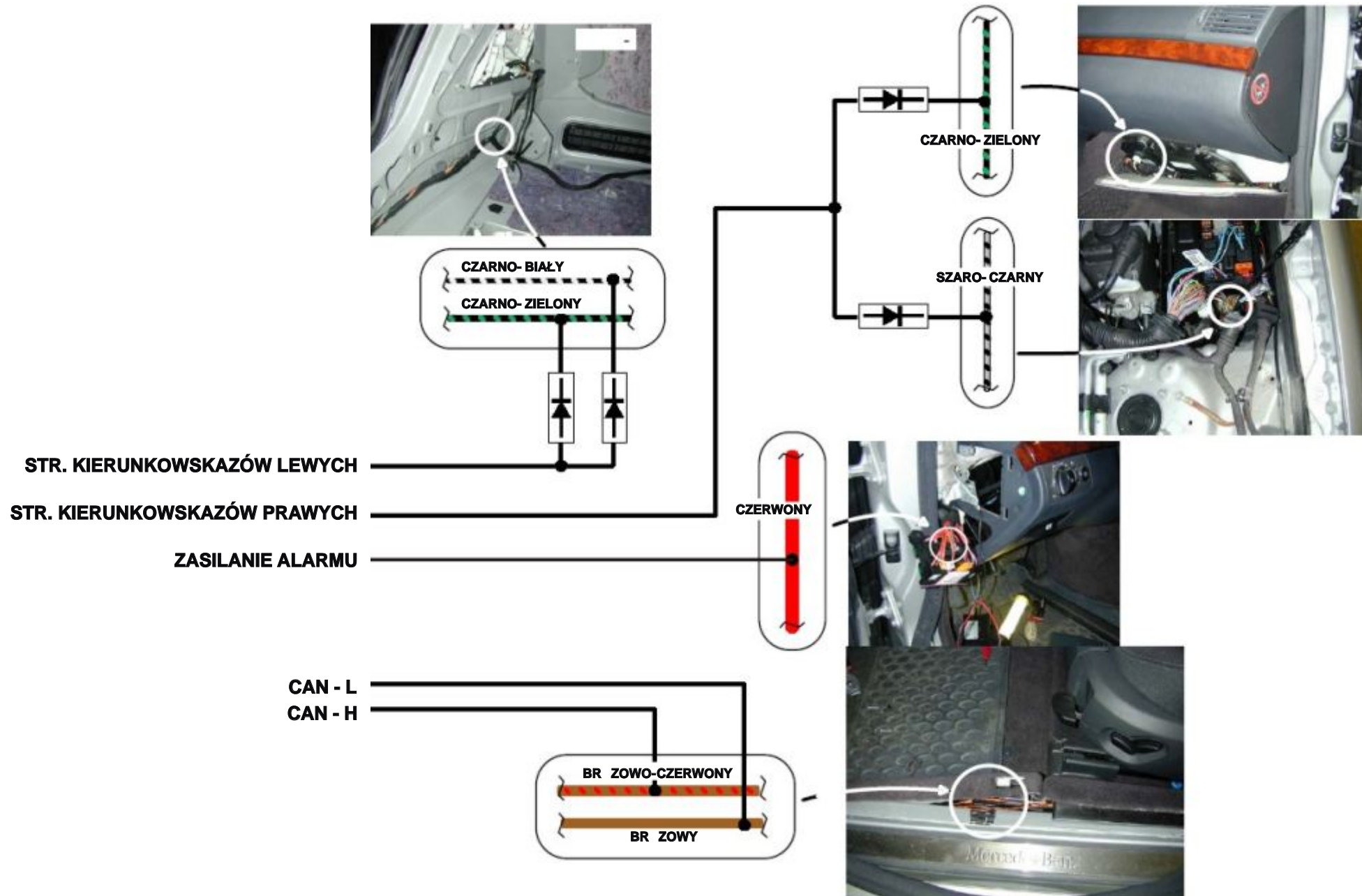



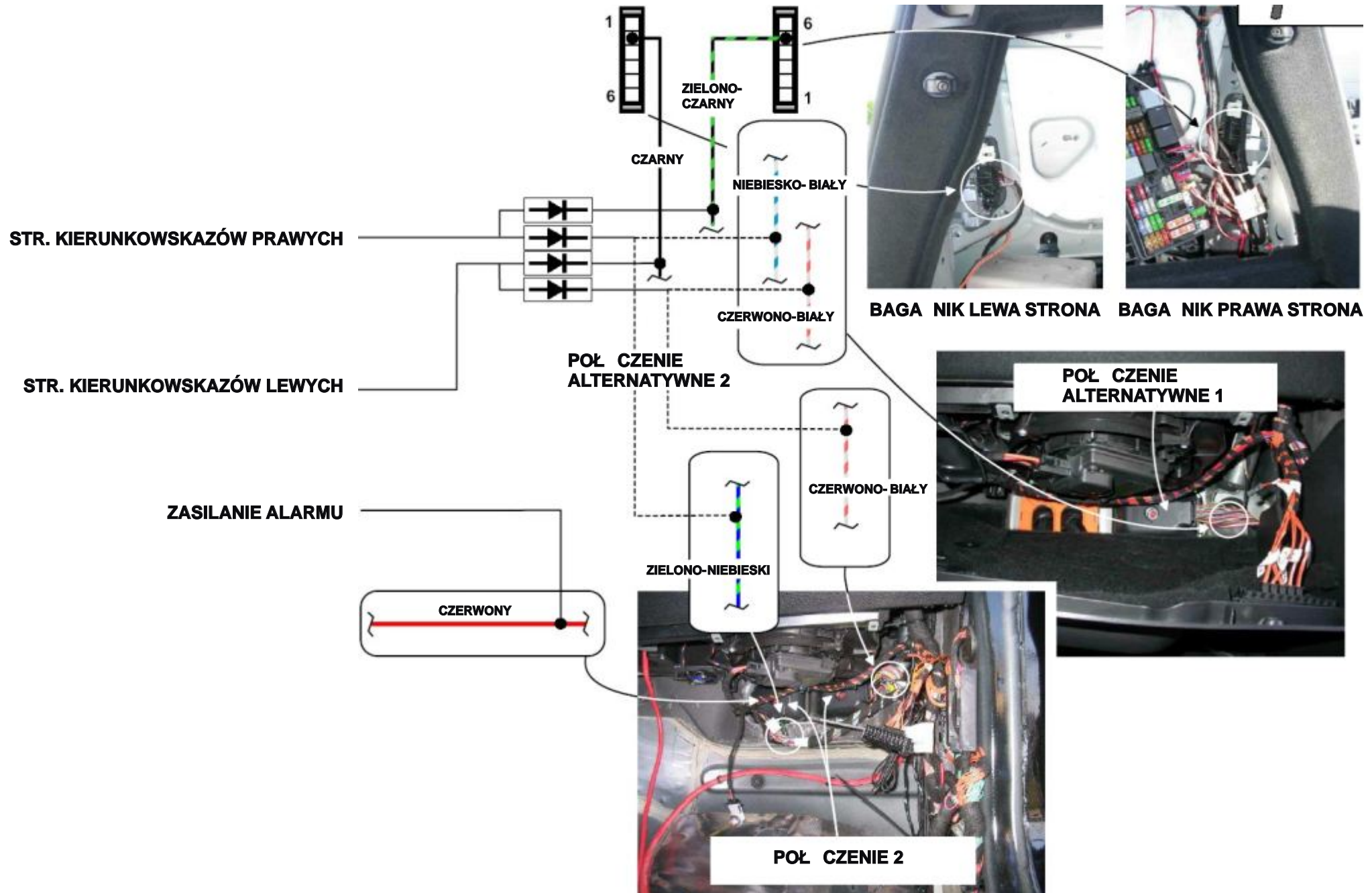

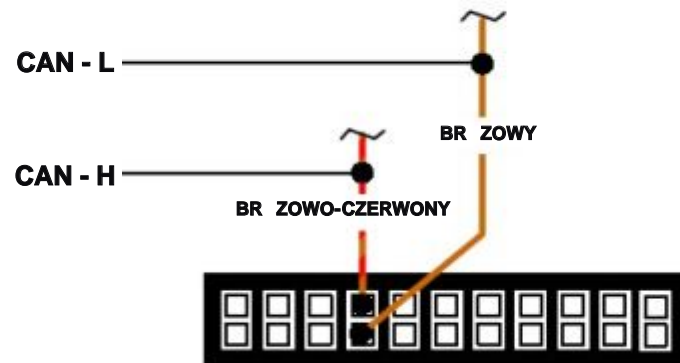

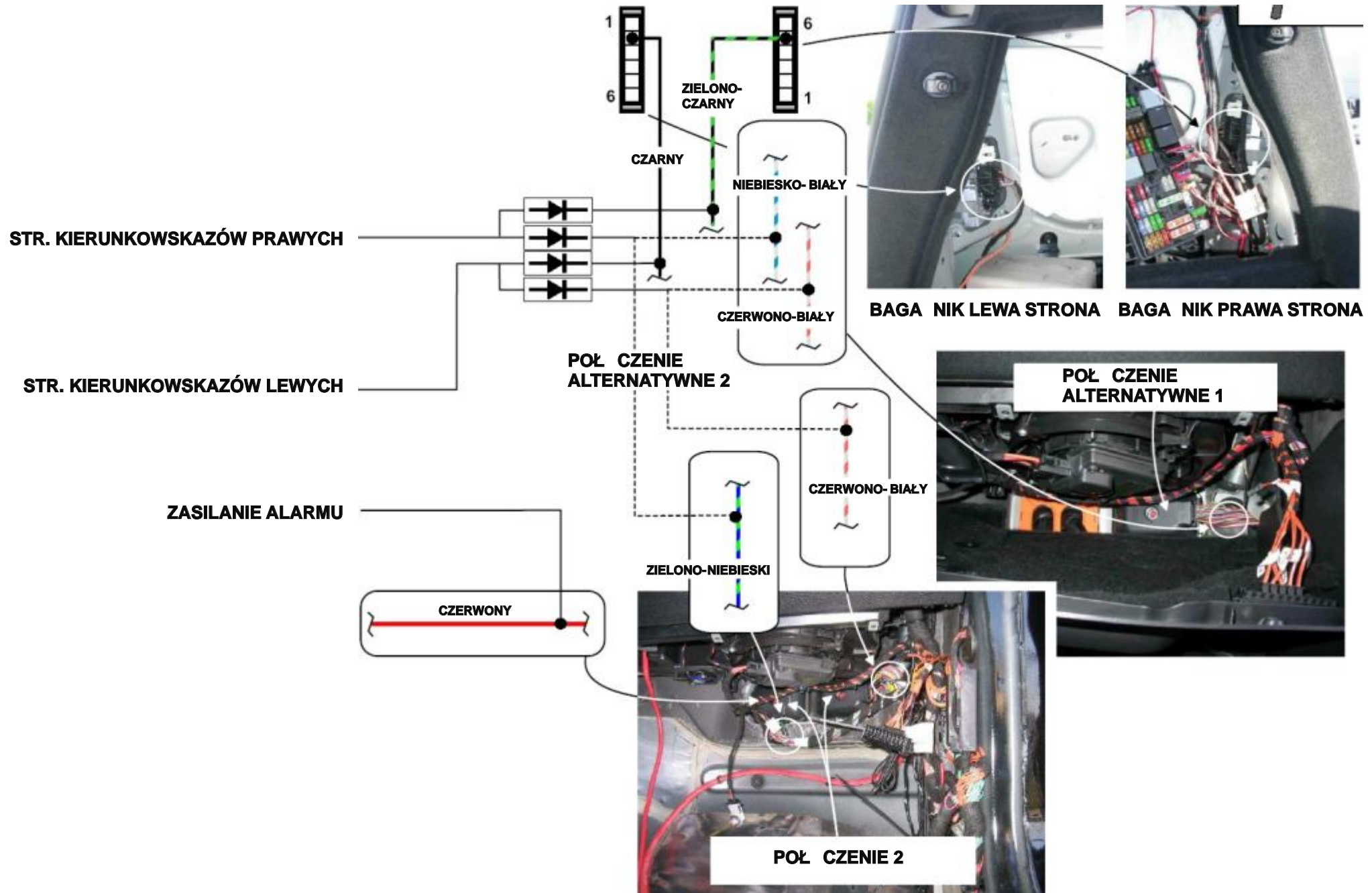



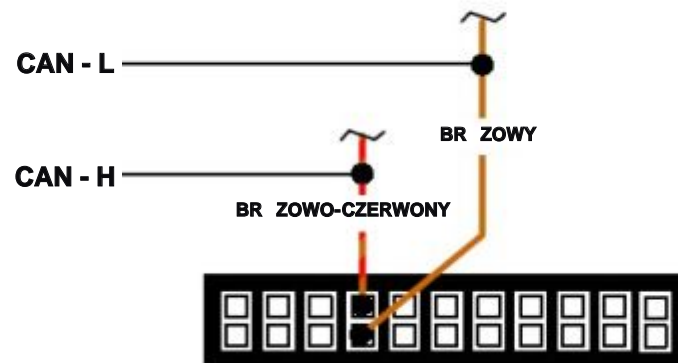



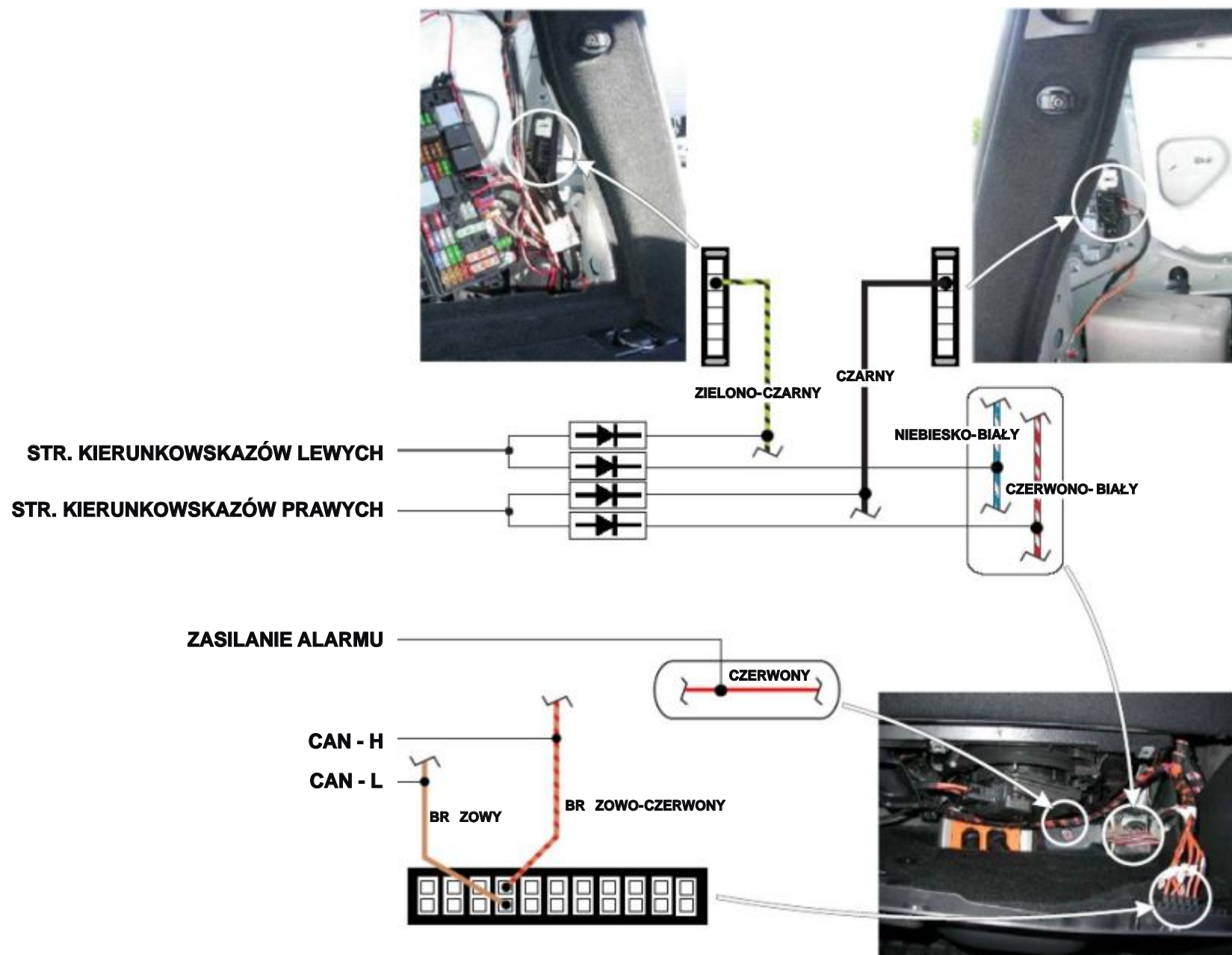

**BAGA NIK LEWA STRONA**



**BAGA NIK PRAWA STRONA**



**STR. KIERUNKOWSKAZÓW PRAWYCH**  
**STR. KIERUNKOWSKAZÓW LEWYCH**

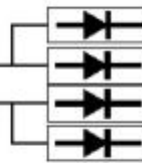

**ZIELONO-CZARNY**

**CZARNY**

**ZIELONO-NIEBIESKI**

**FIOLETOWO-BIAŁY**

**ZASILANIE ALARMU**

**BLOKADA ZAPŁONU**

**BLOKADA ZAPŁONU**

**BIAŁE ZŁ. CZE**

**RÓŻOWY**

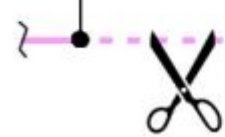

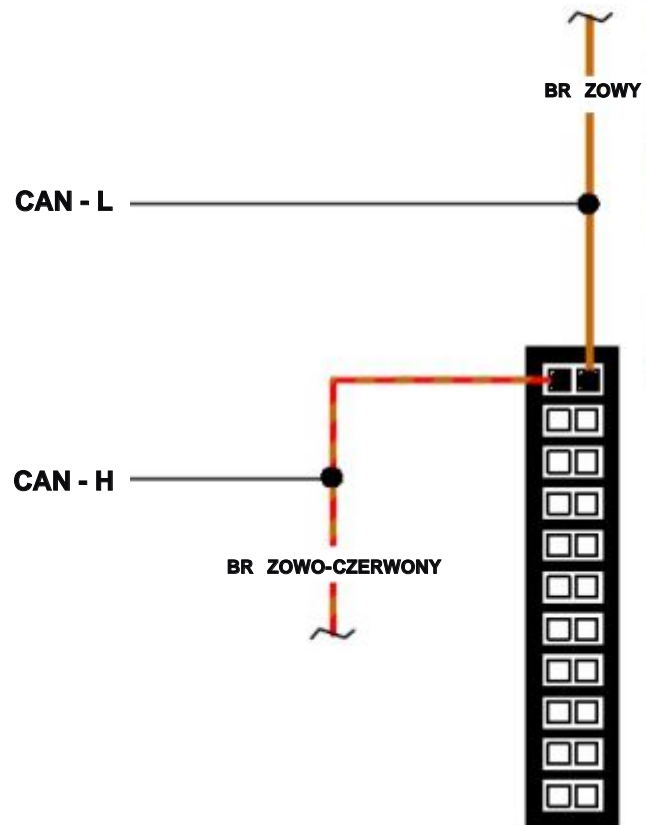

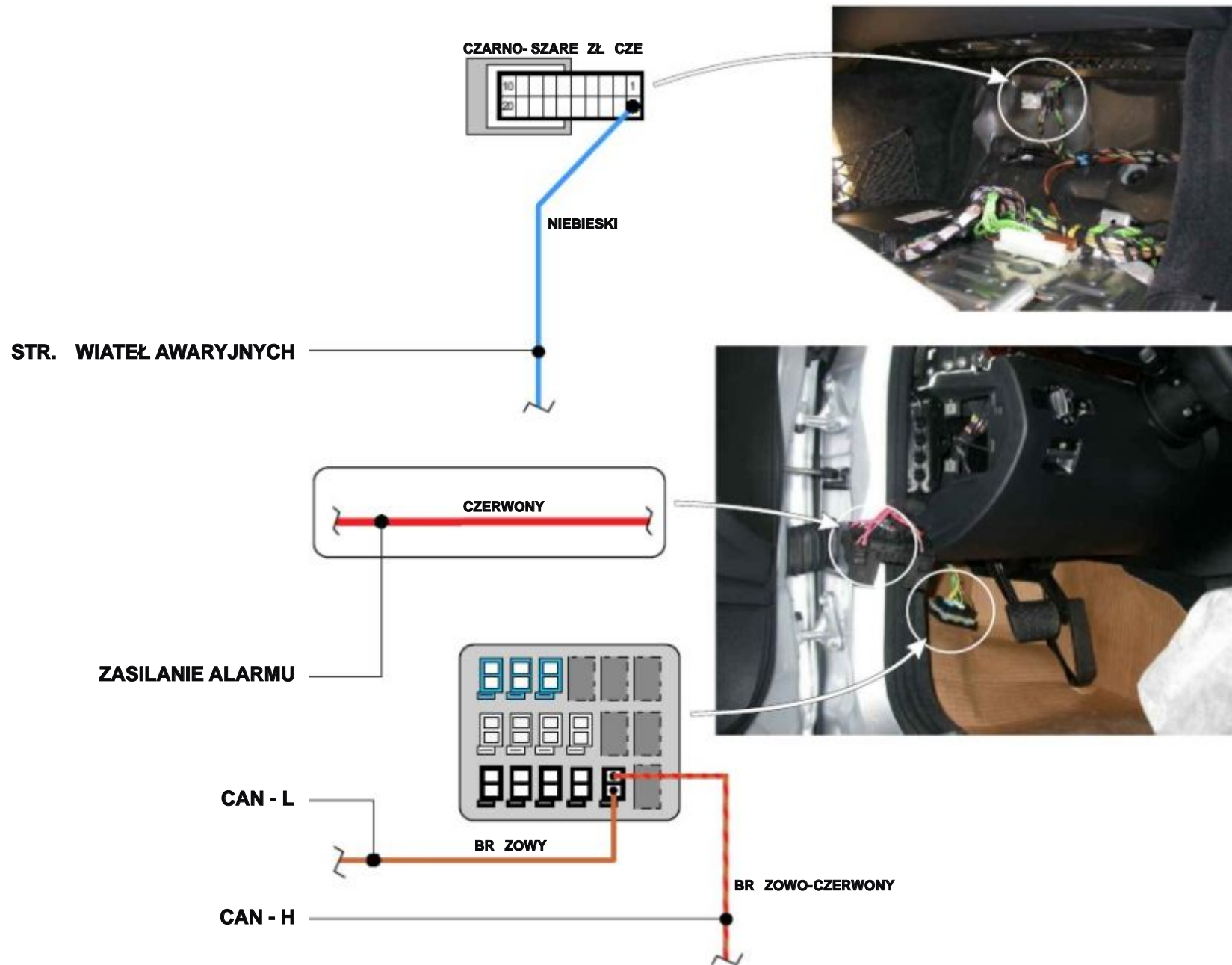



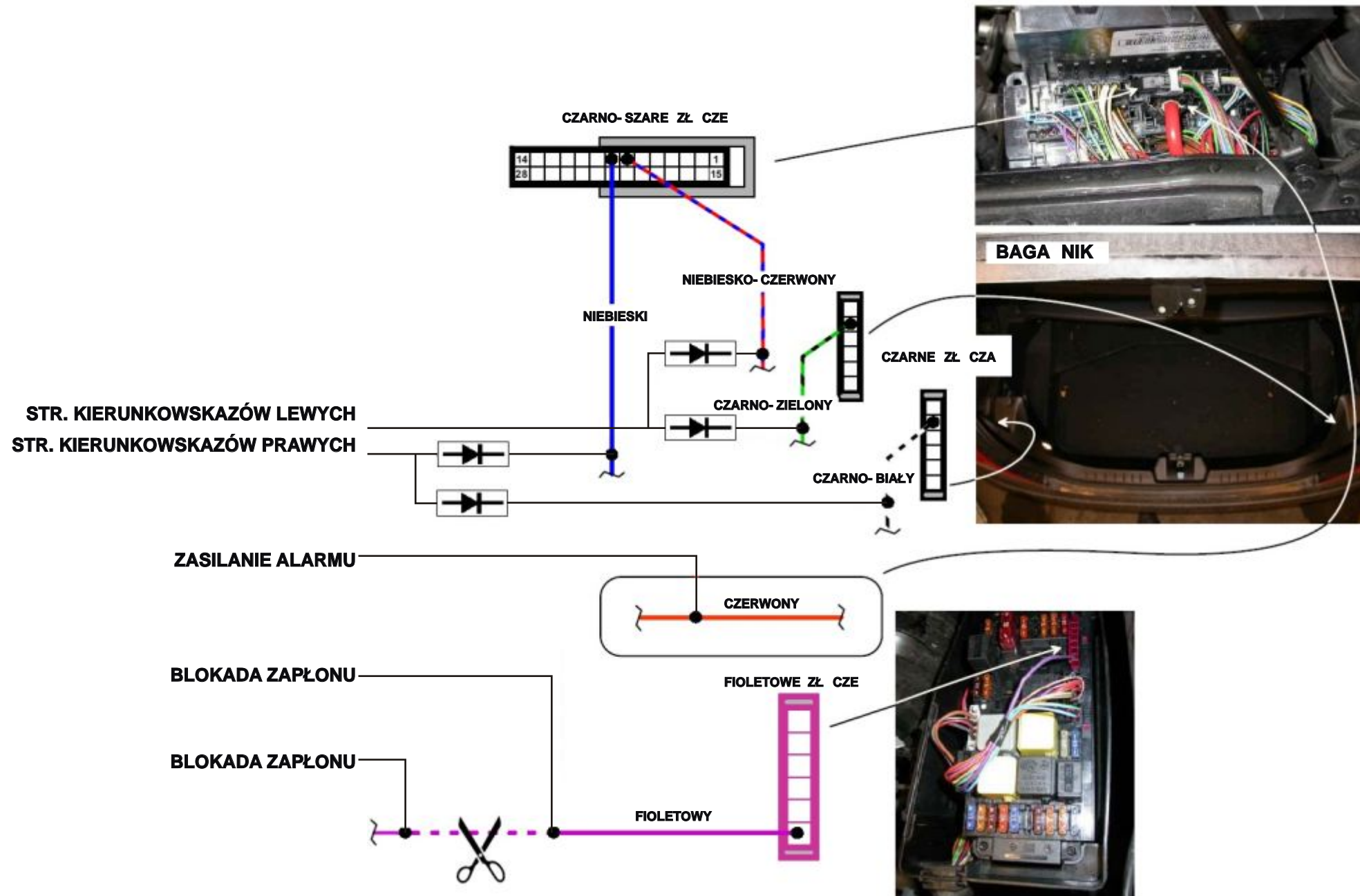

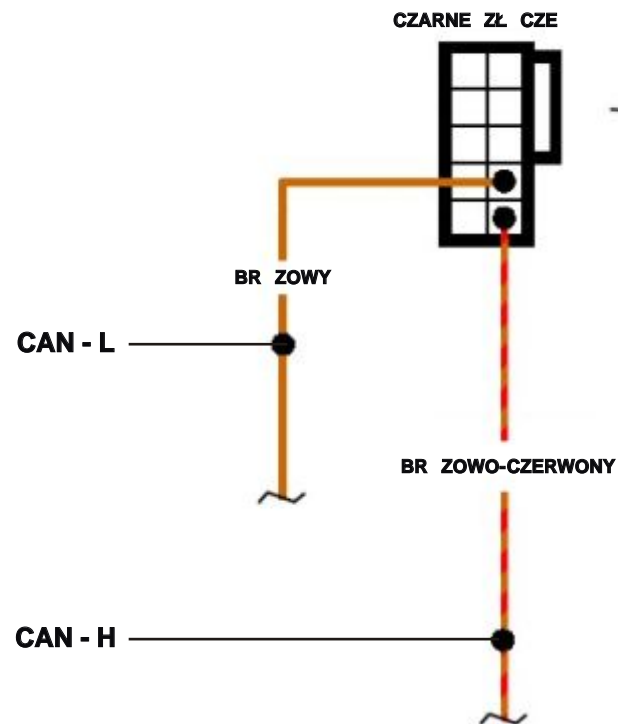
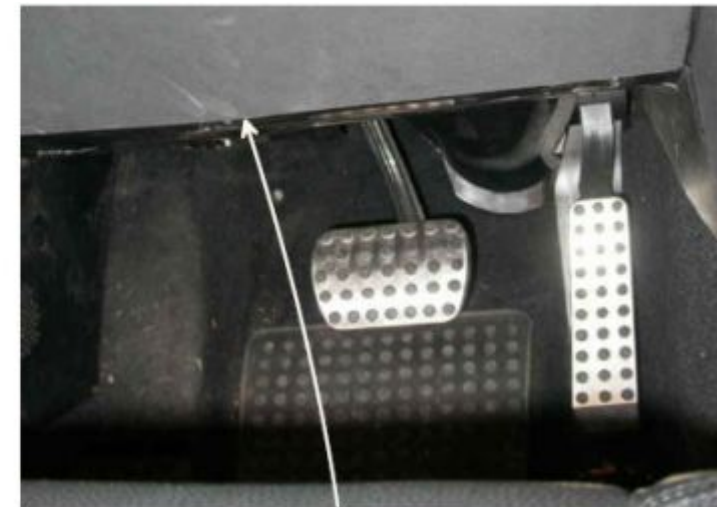

**ZA LEWA PRZEDNI LAMP**



**ZA SIEDZENIEM PASA ERA**

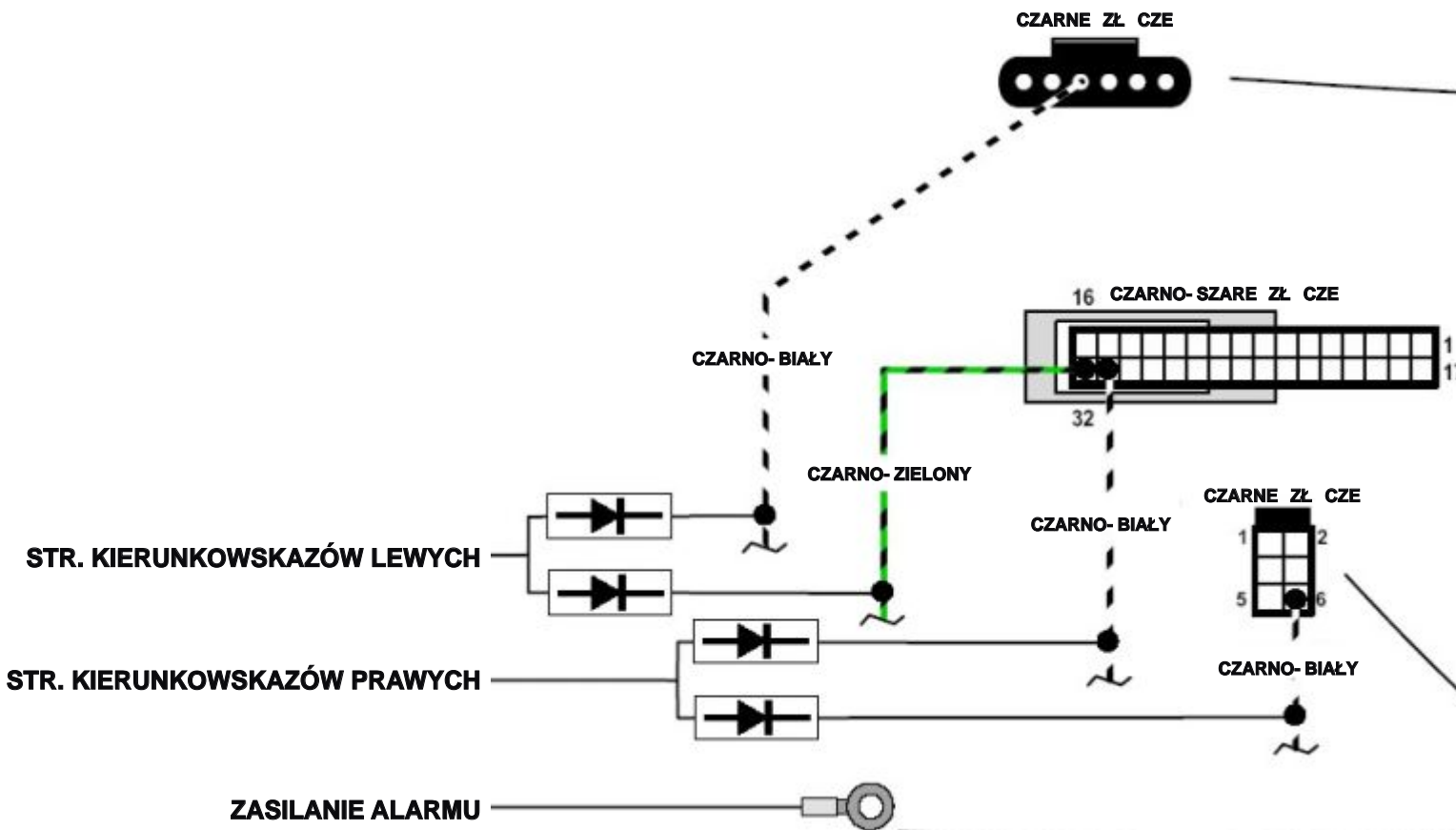

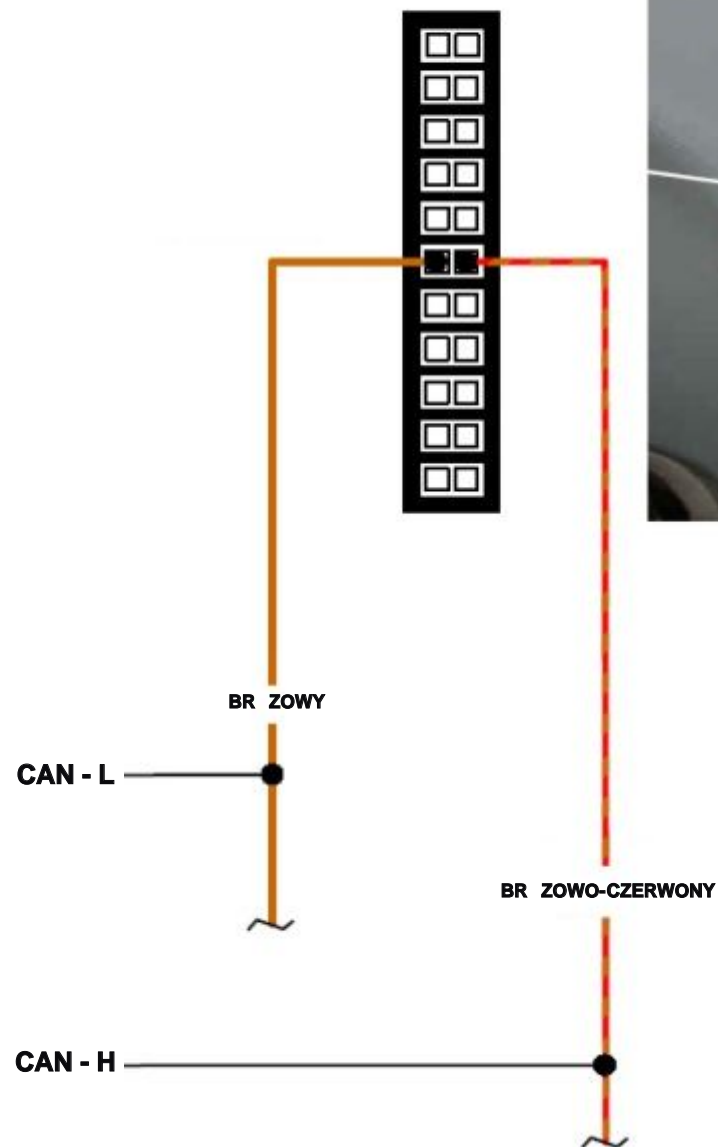



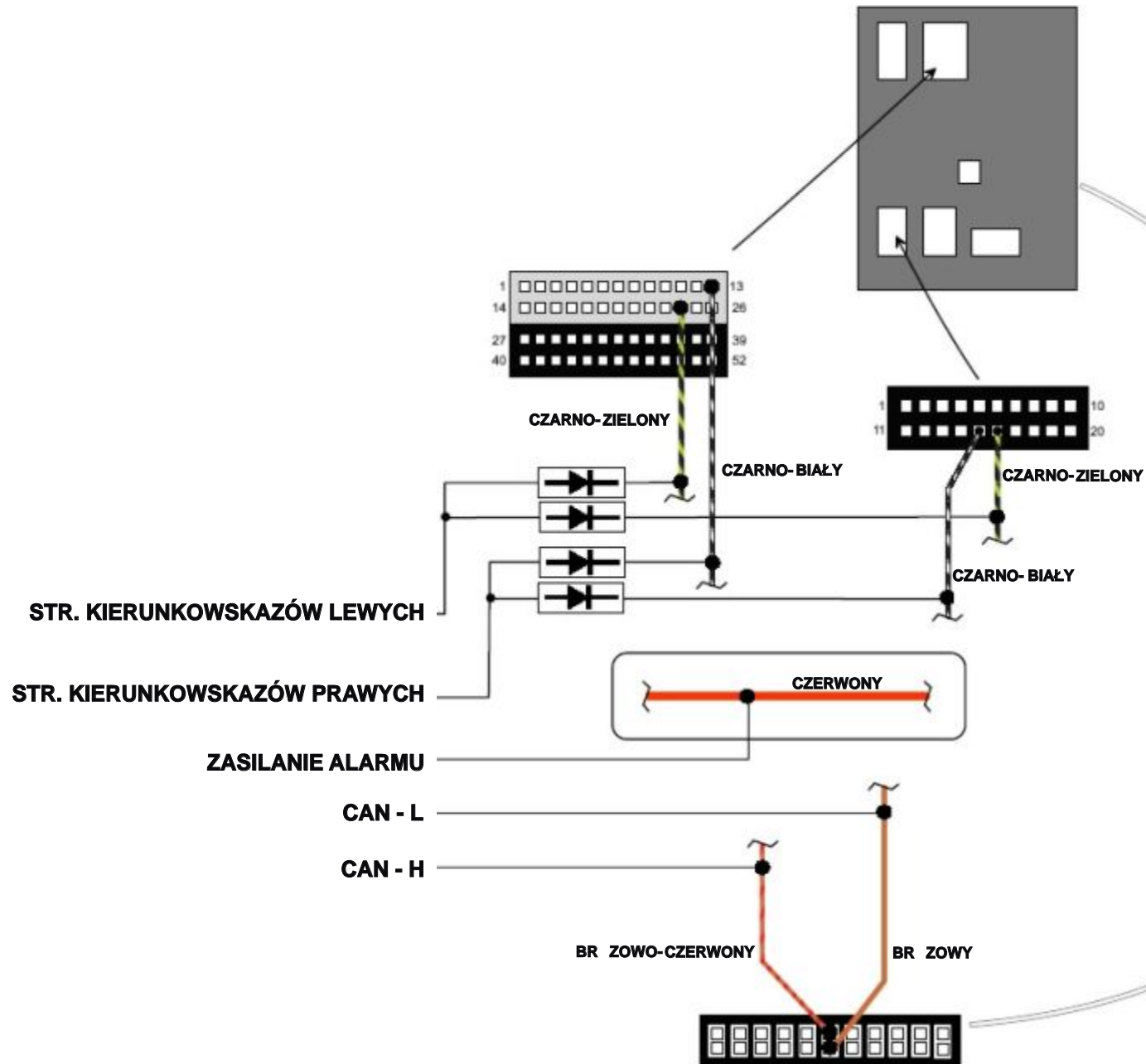

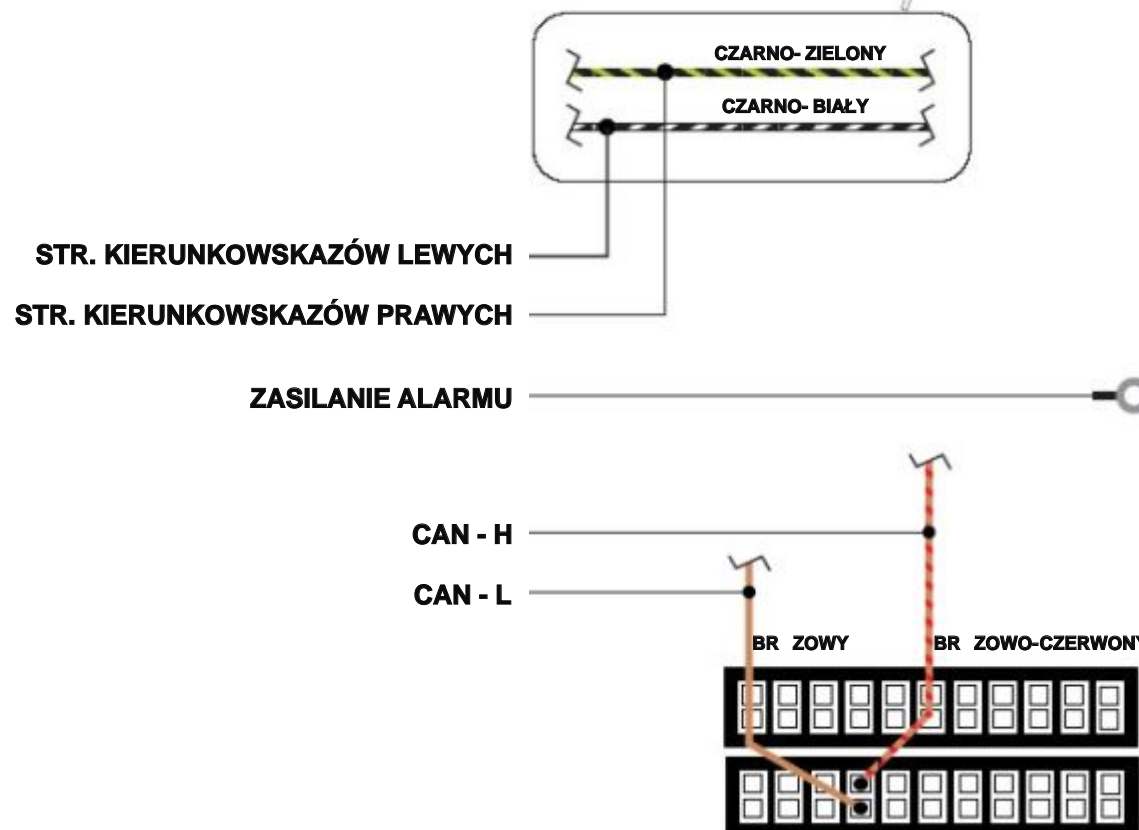

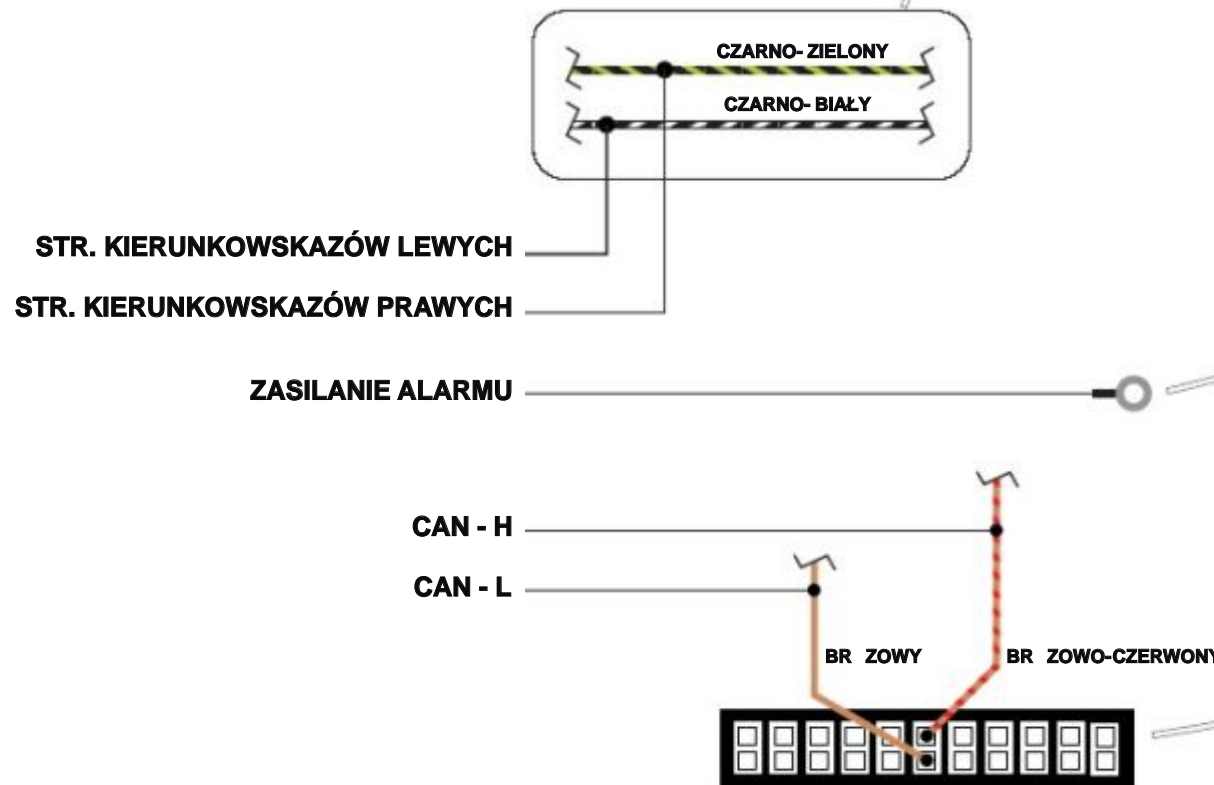

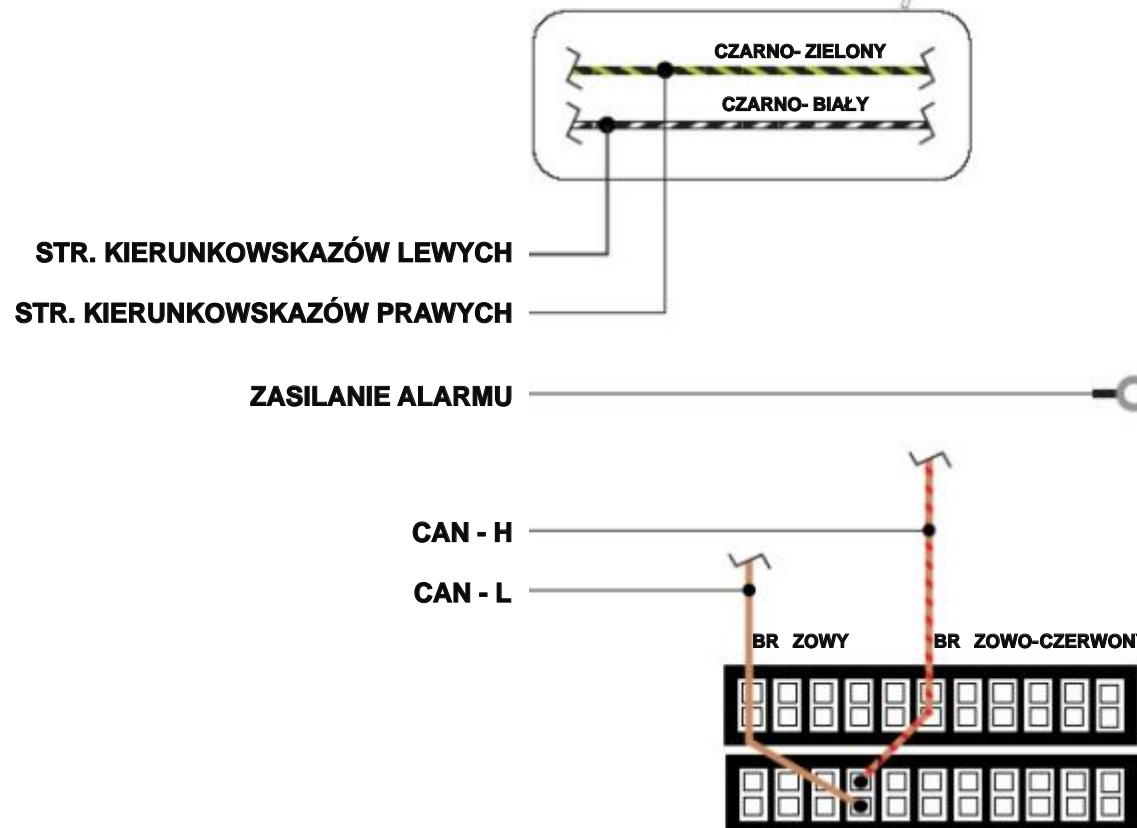



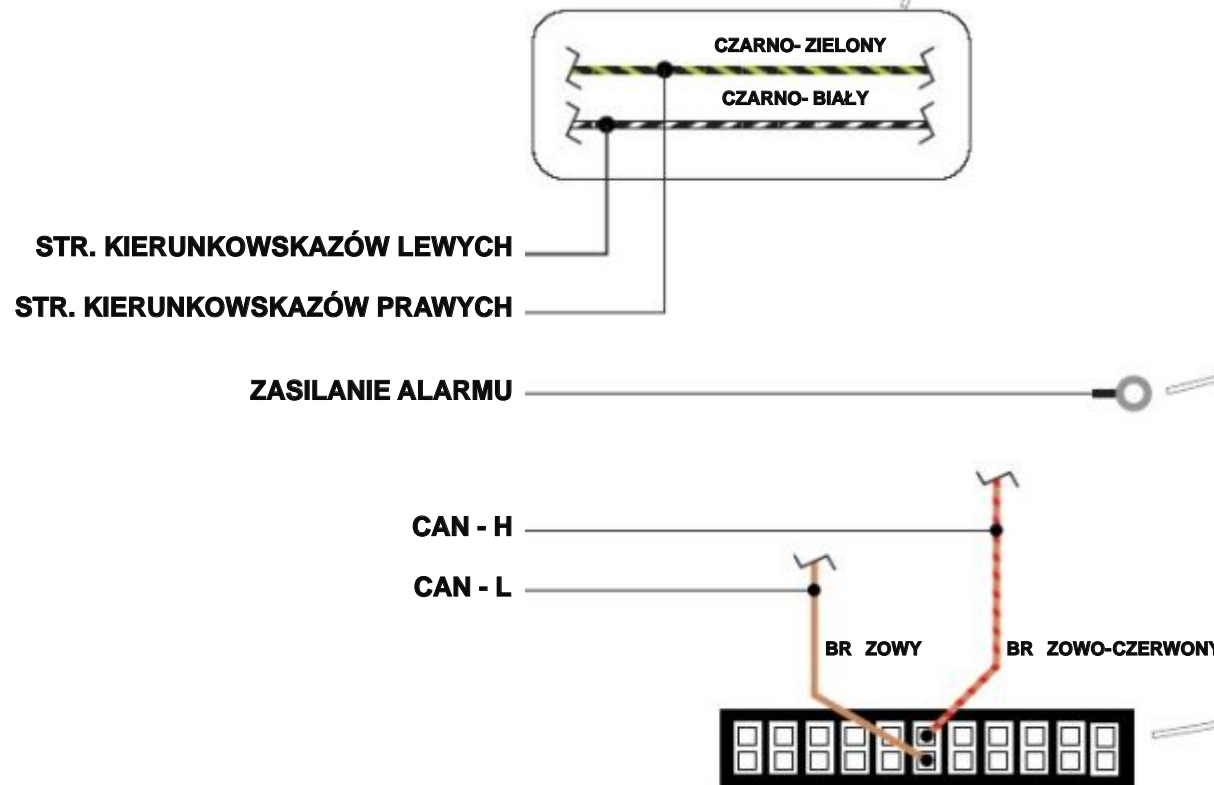





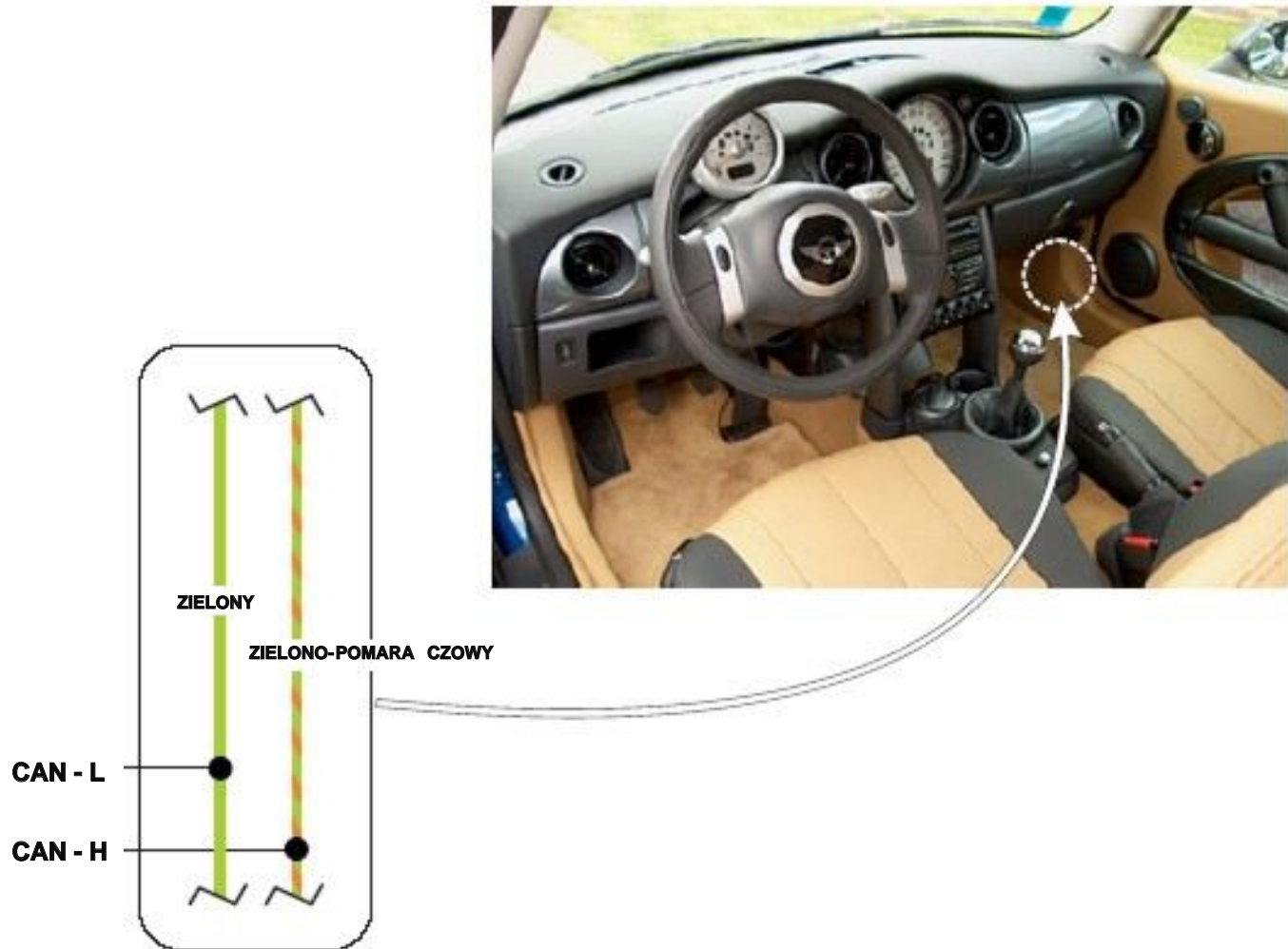



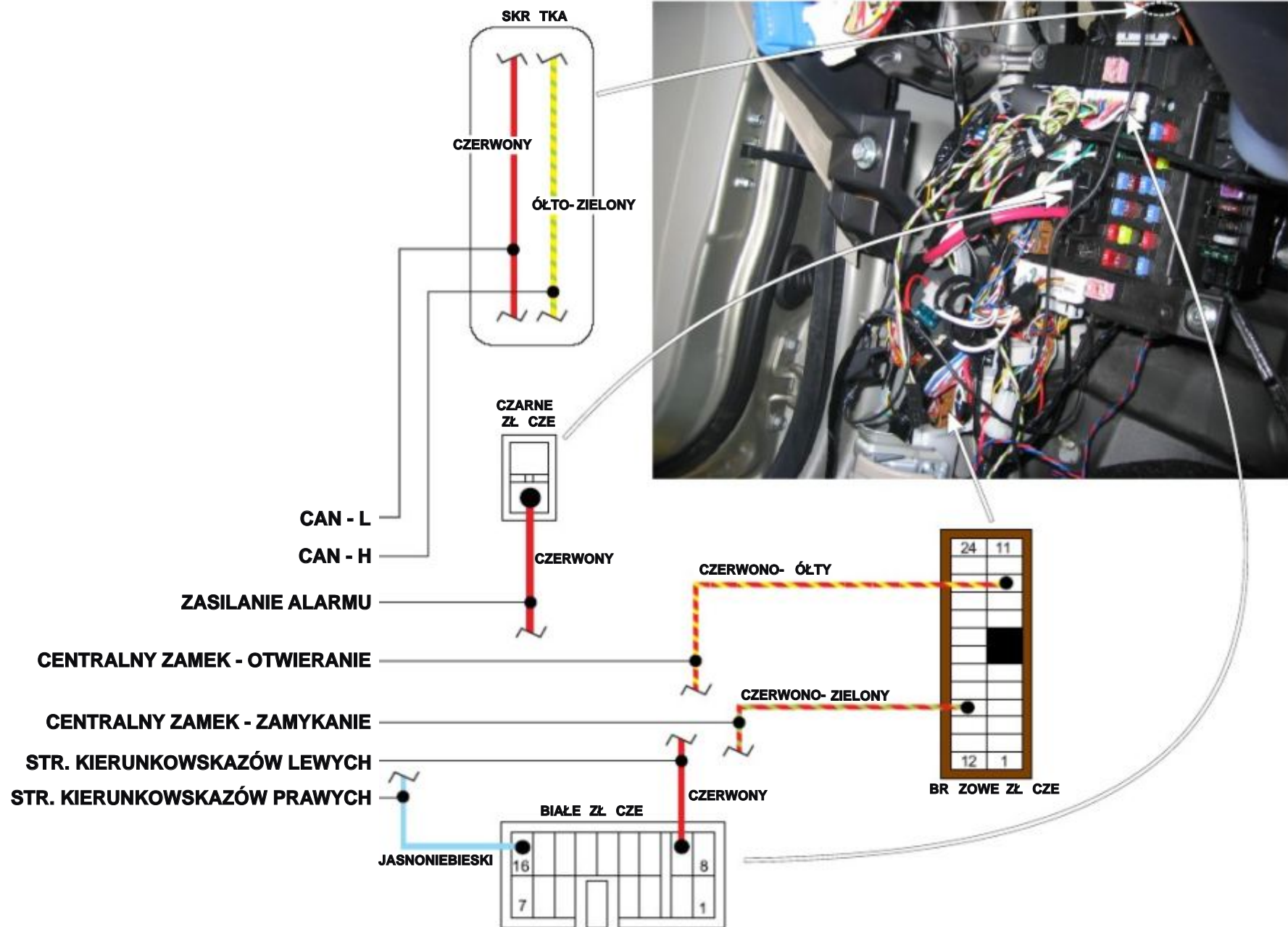

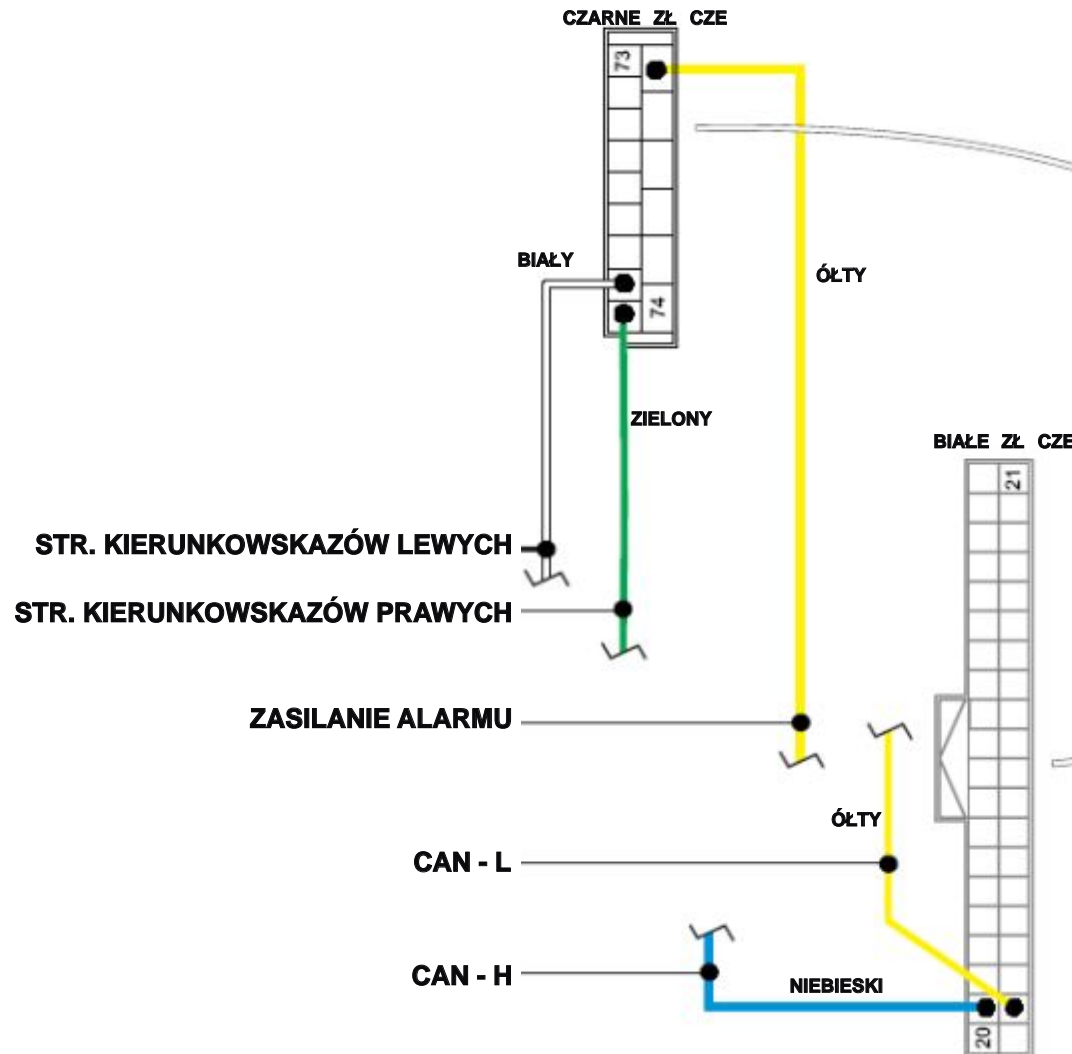

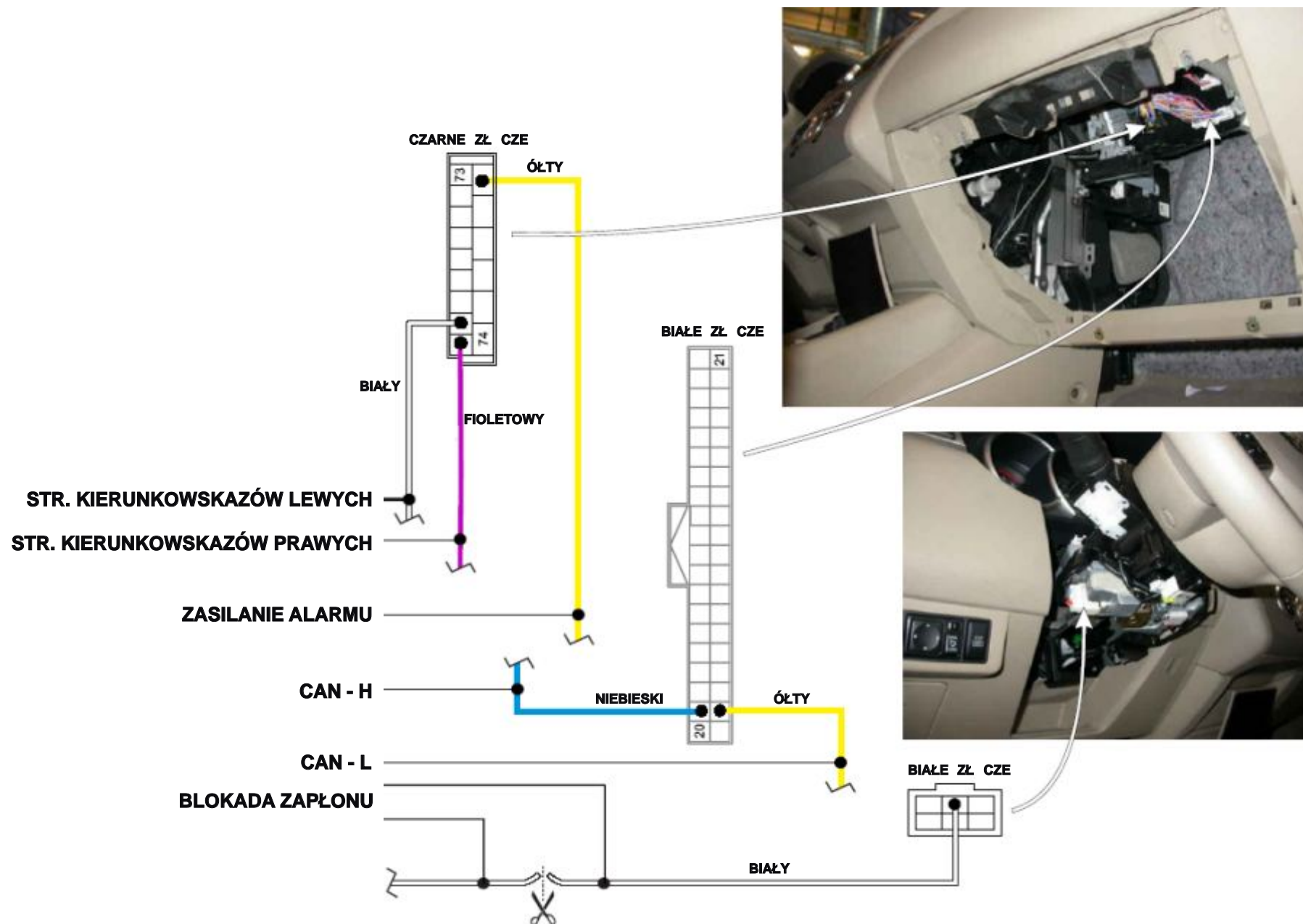

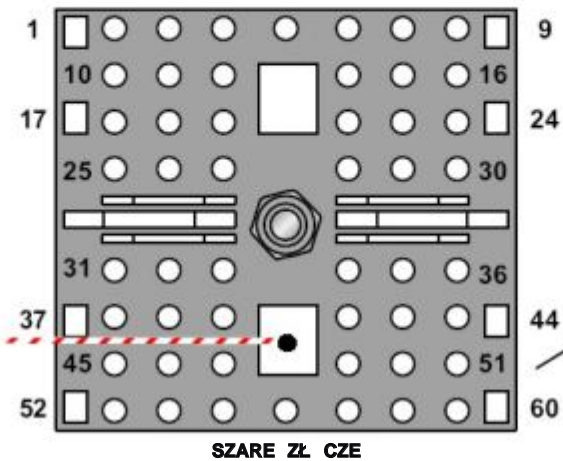

CZERWONO-BIAŁY  
PIN 48

ZASILANIE ALARMU

BLOKADA ZAPŁONU

BLOKADA ZAPŁONU



ÓŁTY  
PIN 22

CZARNE ZŁ. CZE

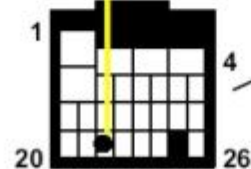



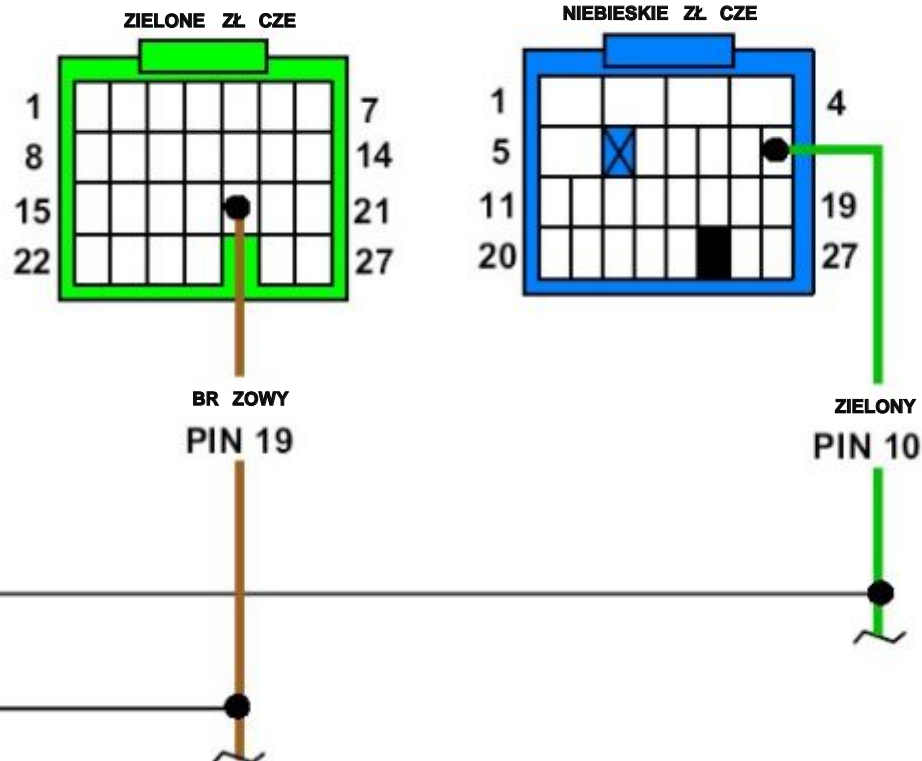



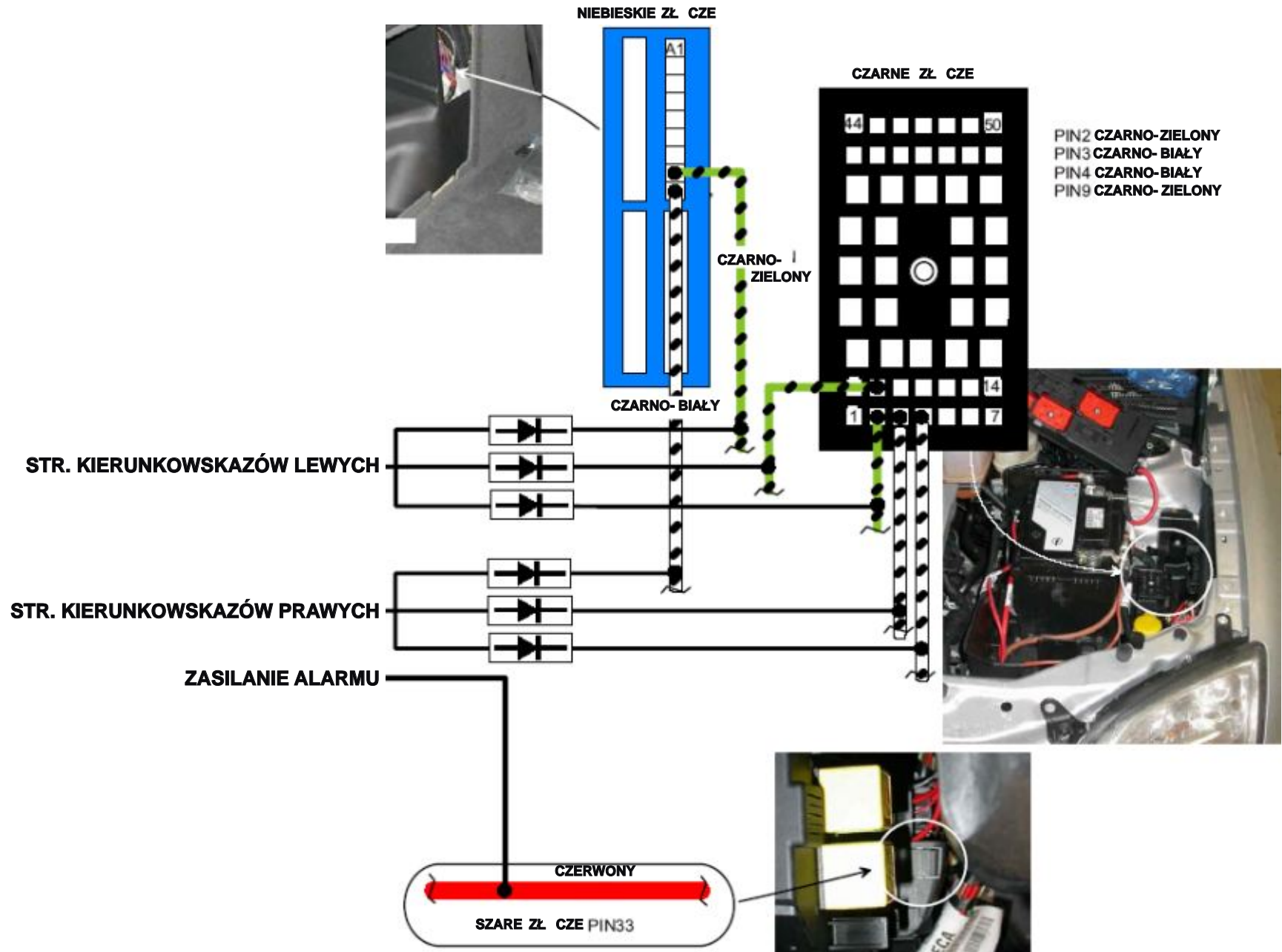

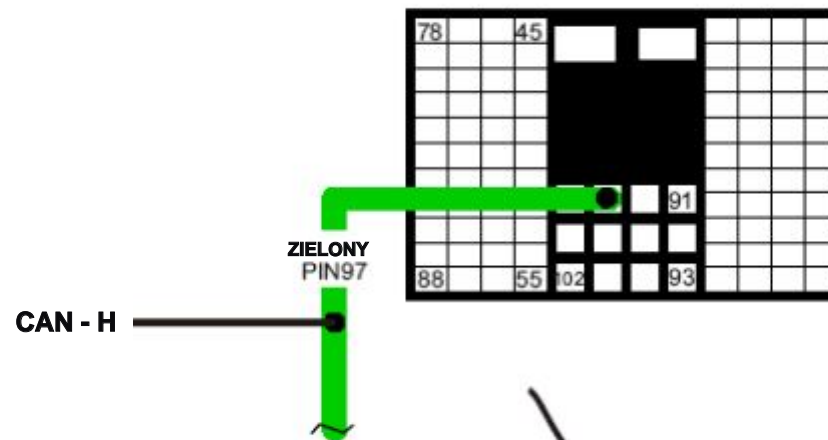



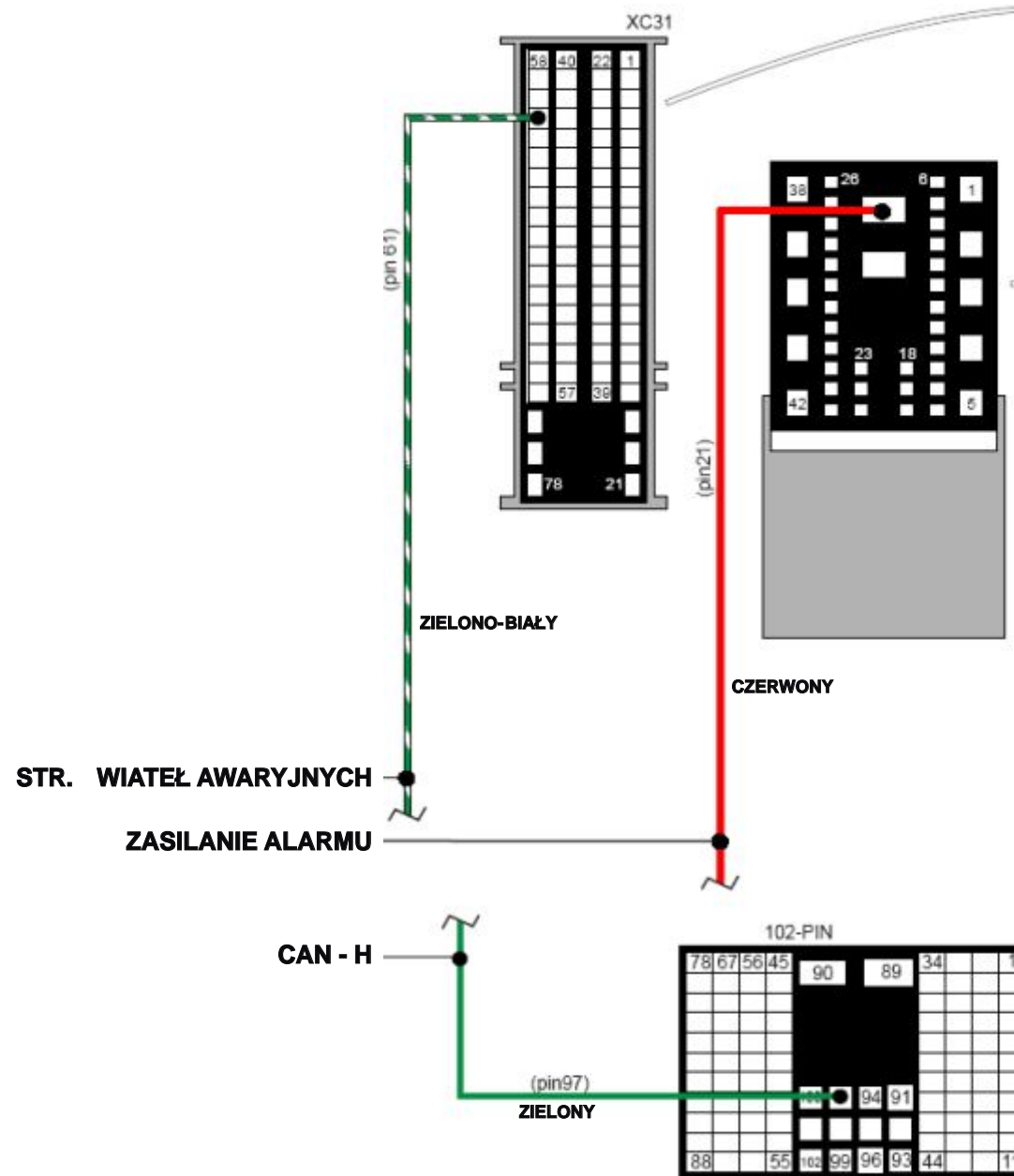

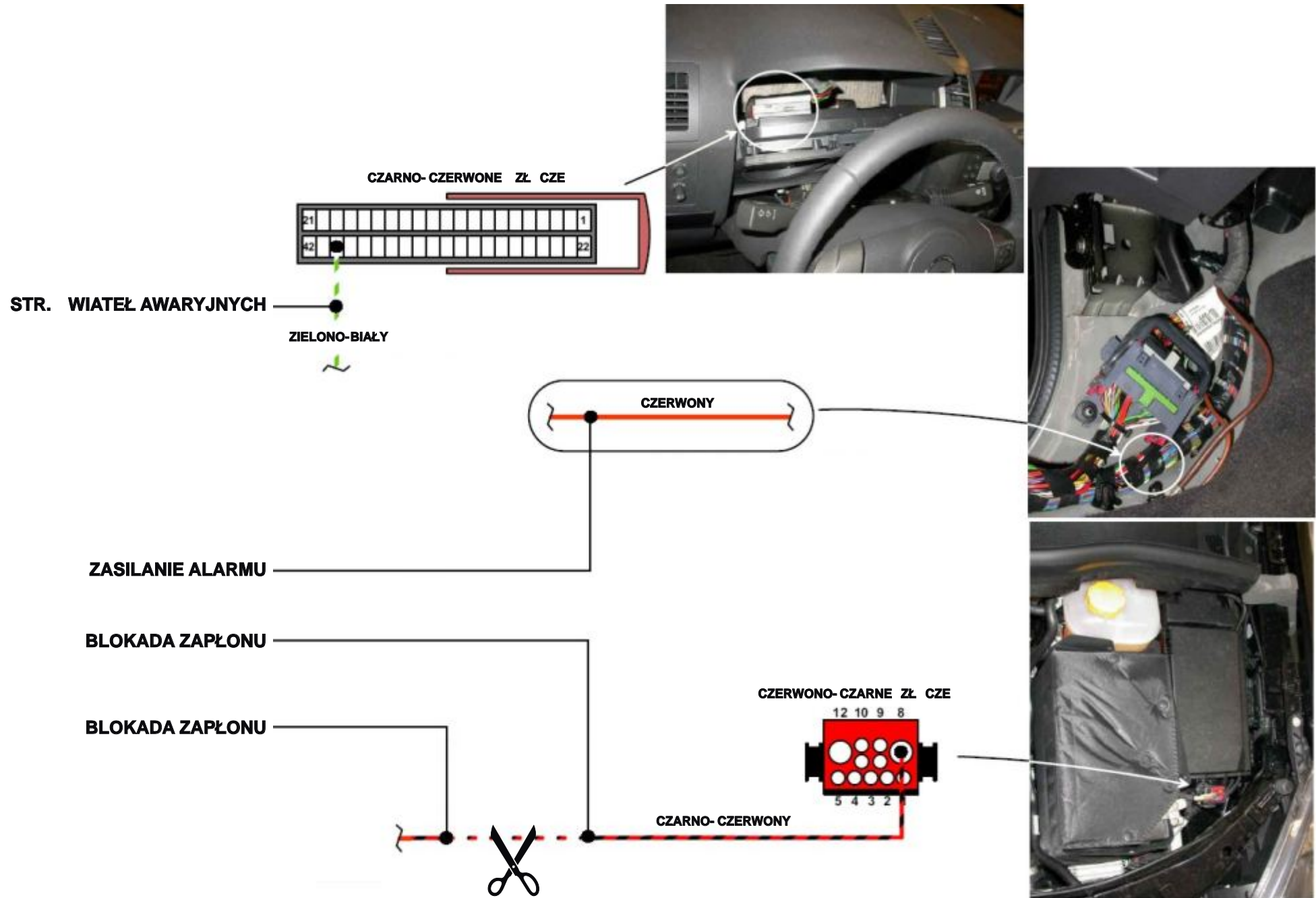

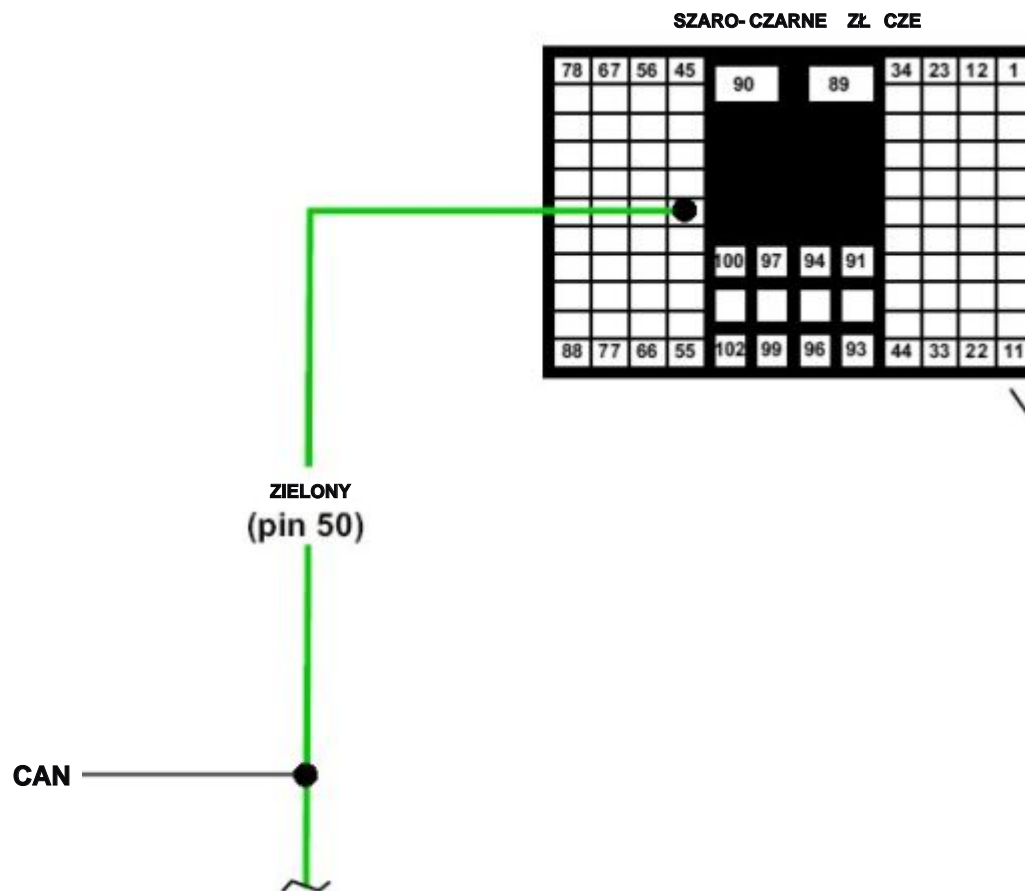





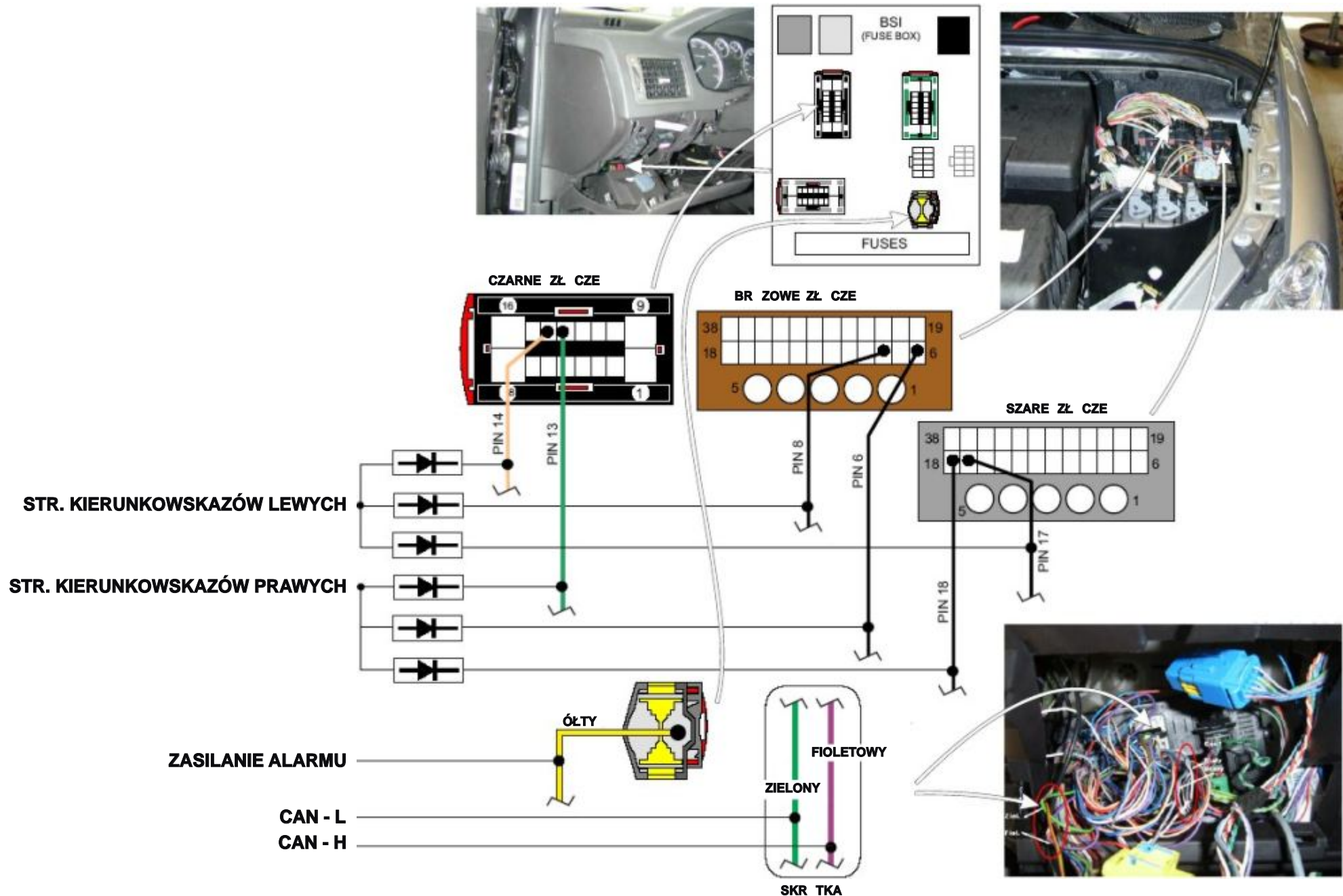

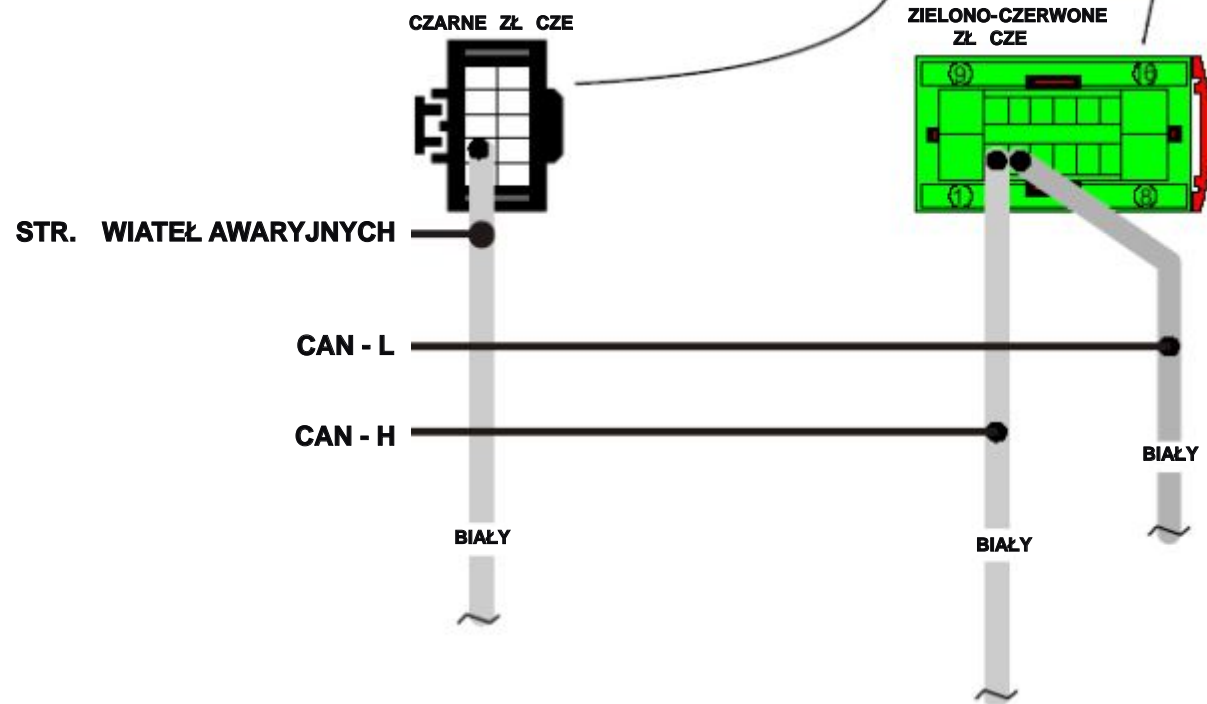

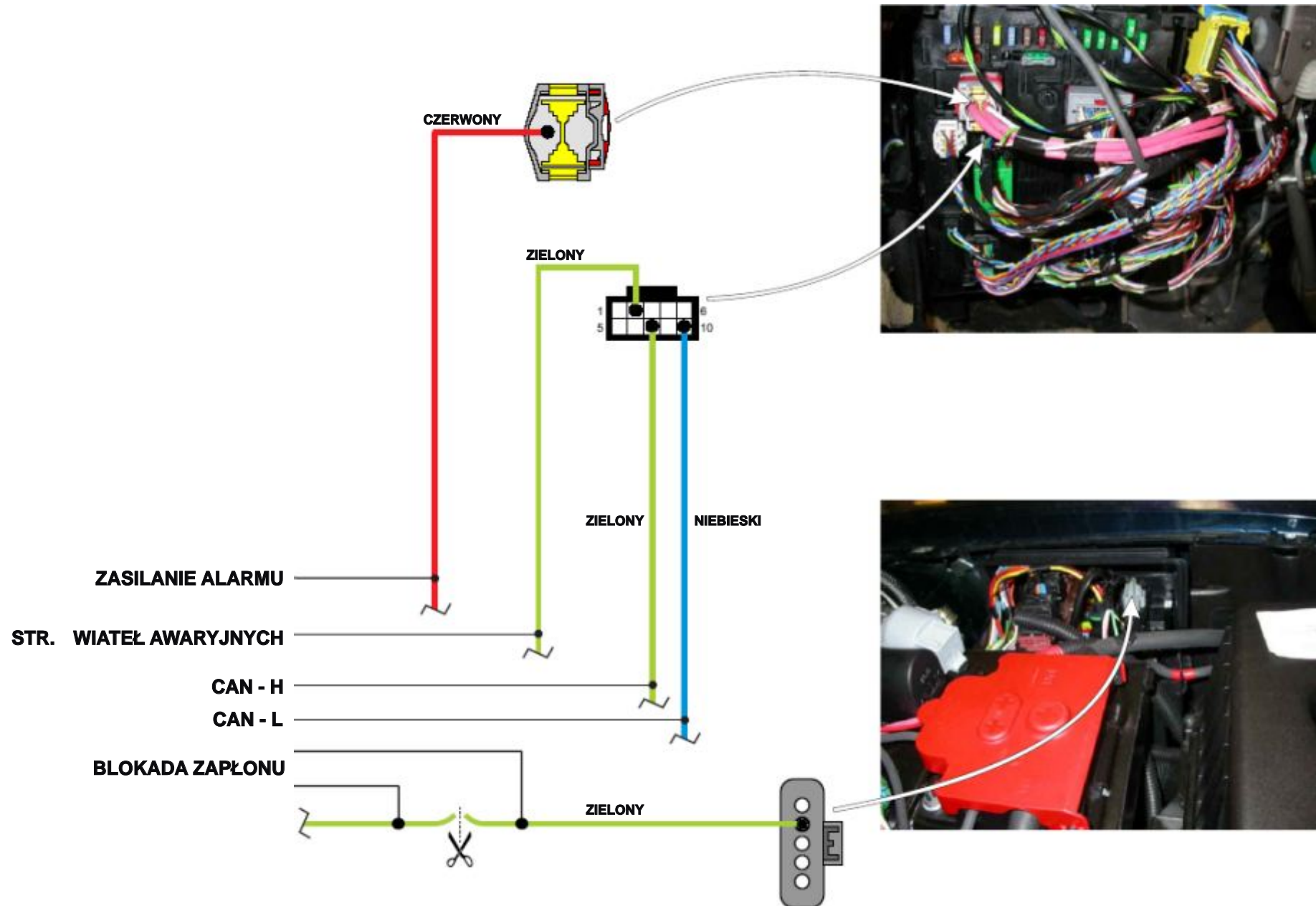



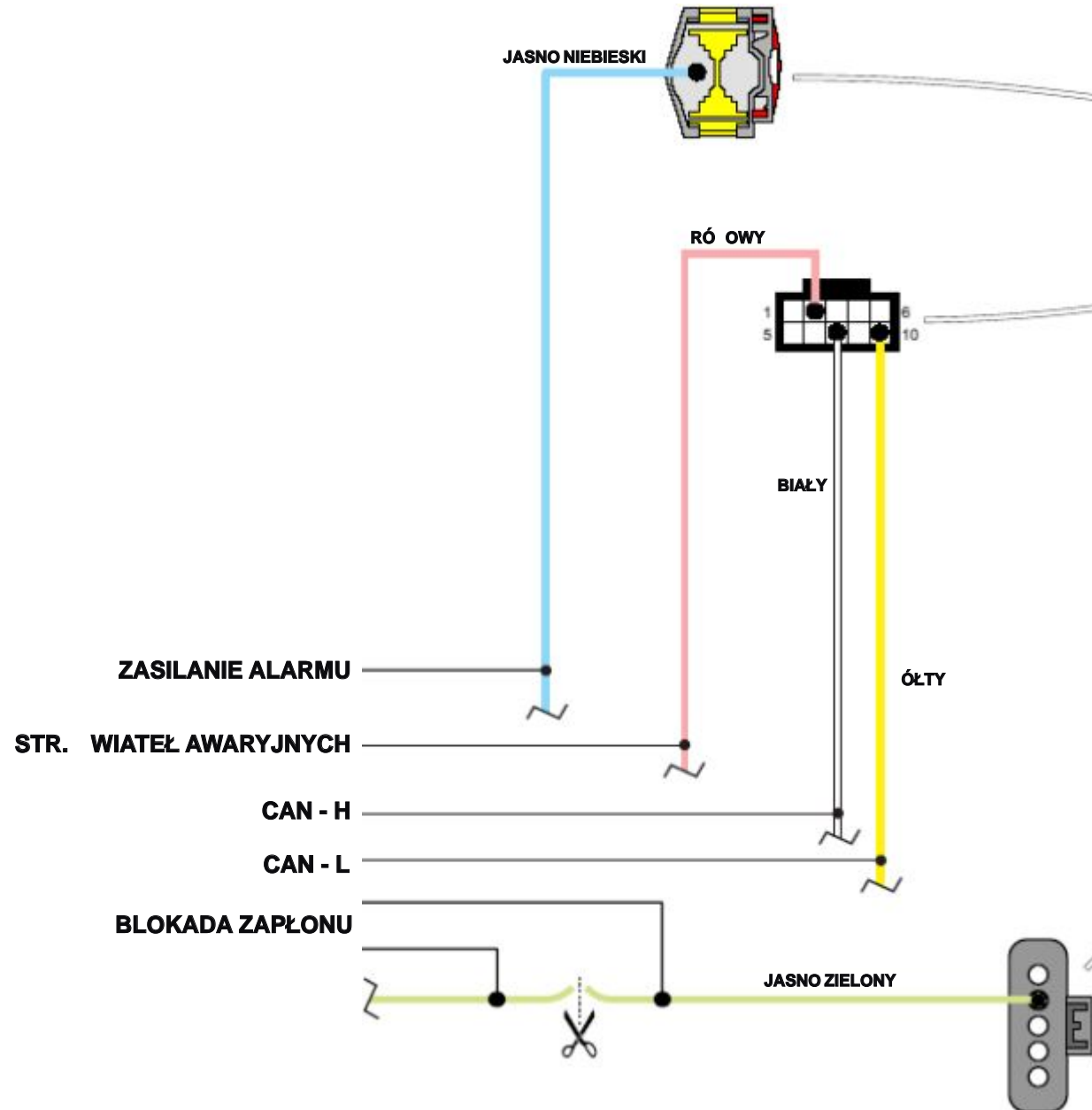





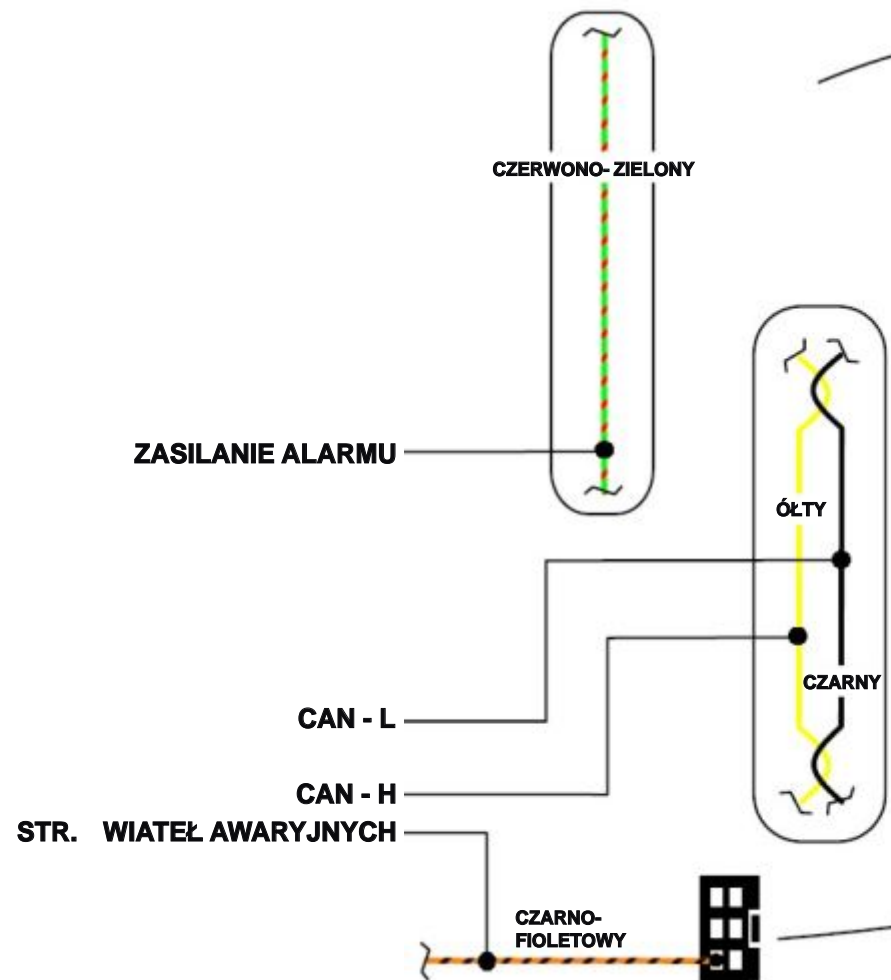

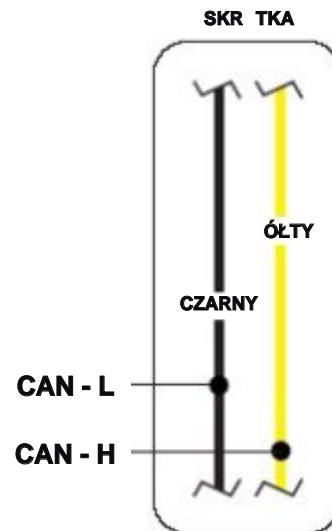

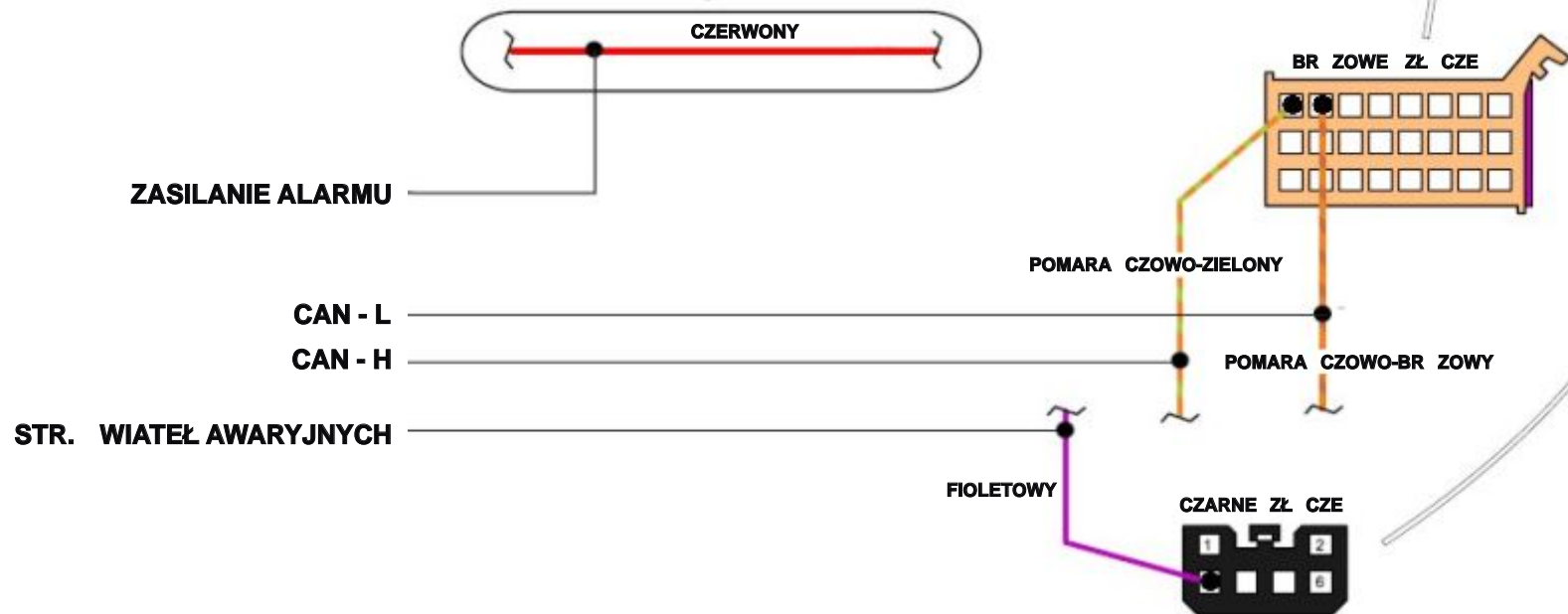



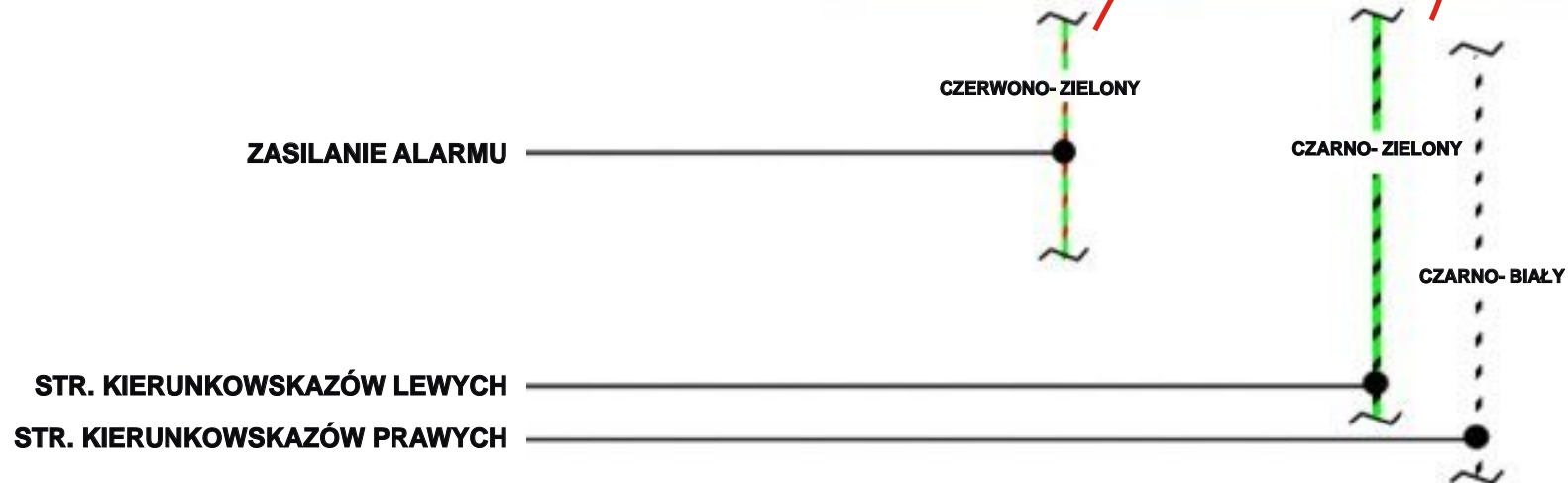
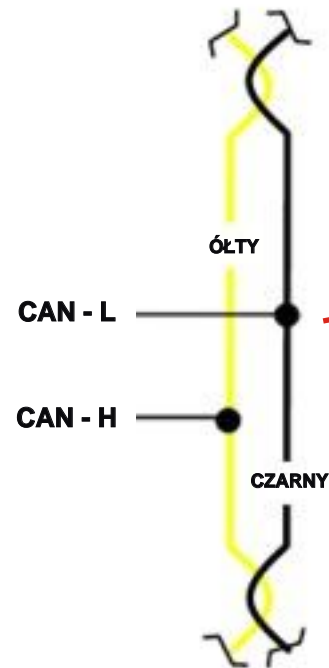

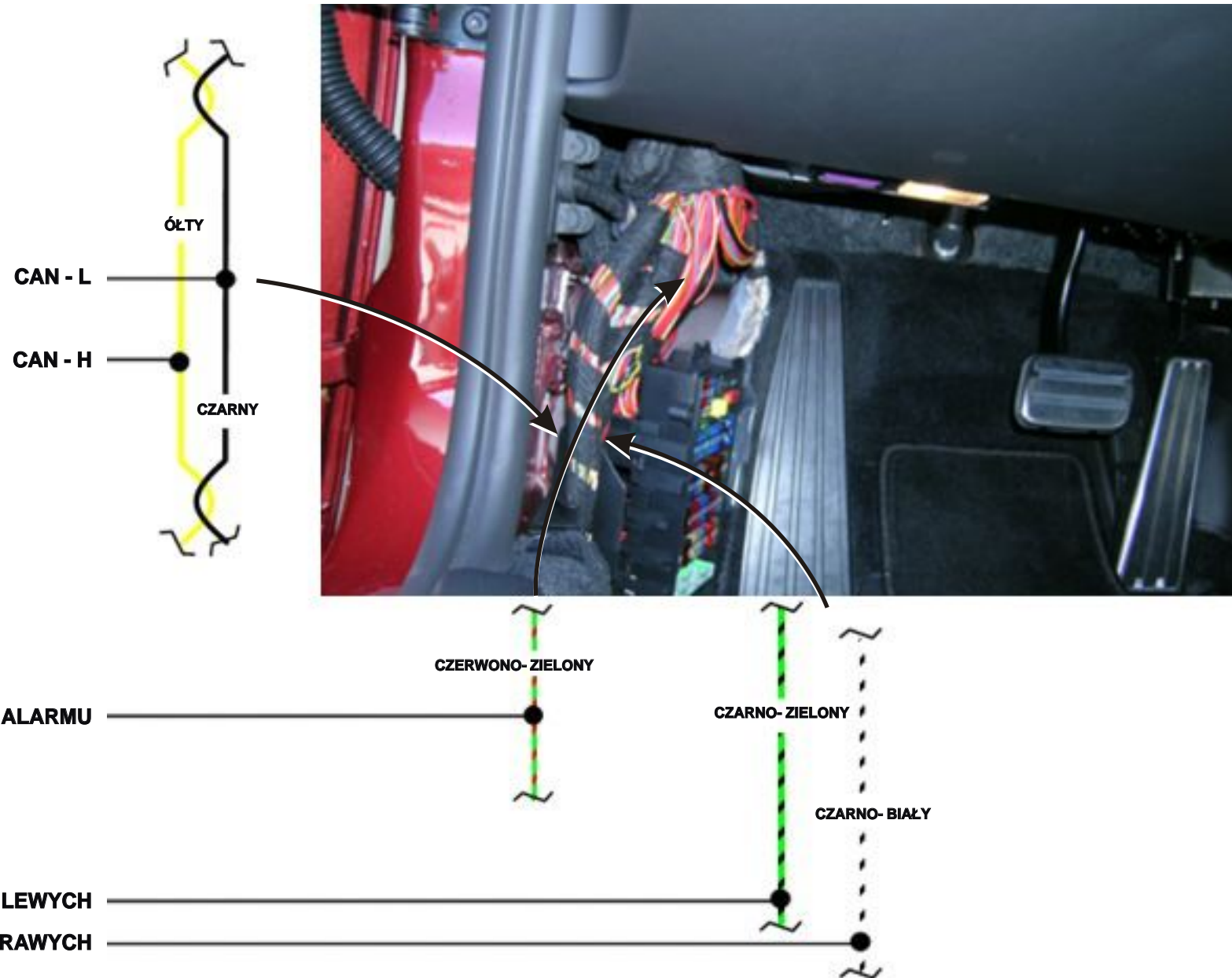



**NIEBIESKIE ŻŁ. CZE**



**CZARNE ŻŁ. CZE**

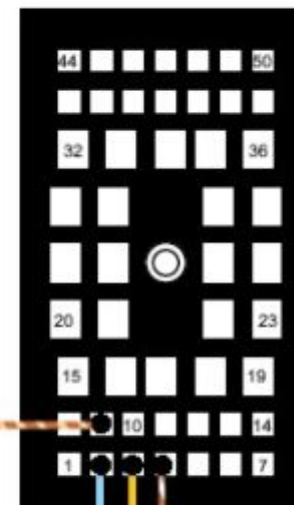

- PIN 2 - JASNO NIEBIESKI**
- PIN 3 - ÓŁTY**
- PIN 4 - BR ZOWO-BIAŁY**
- PIN 9 - BR ZOWO-JASNO BR ZOWY**

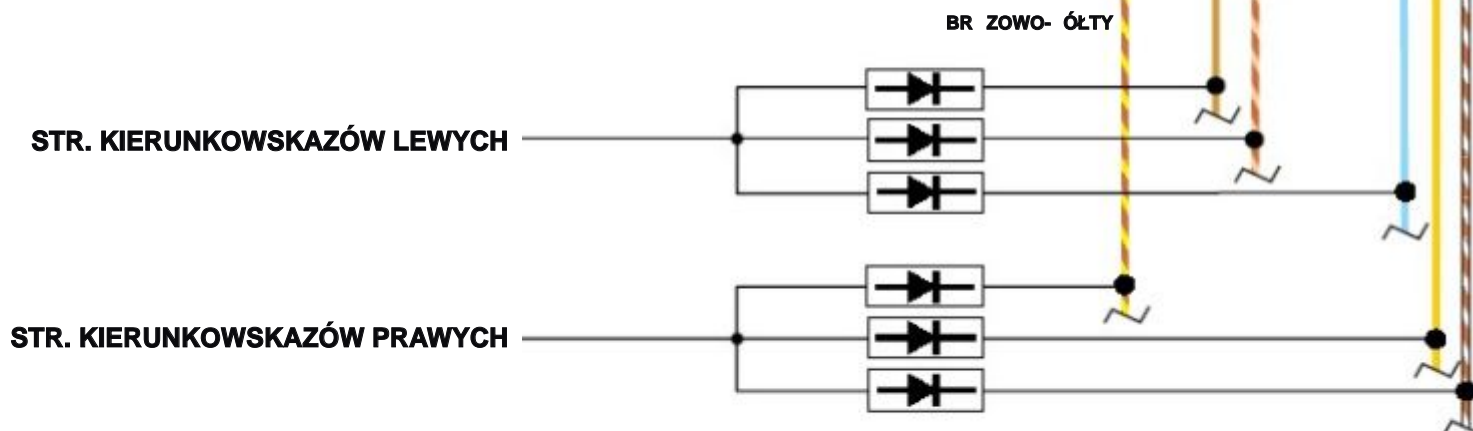

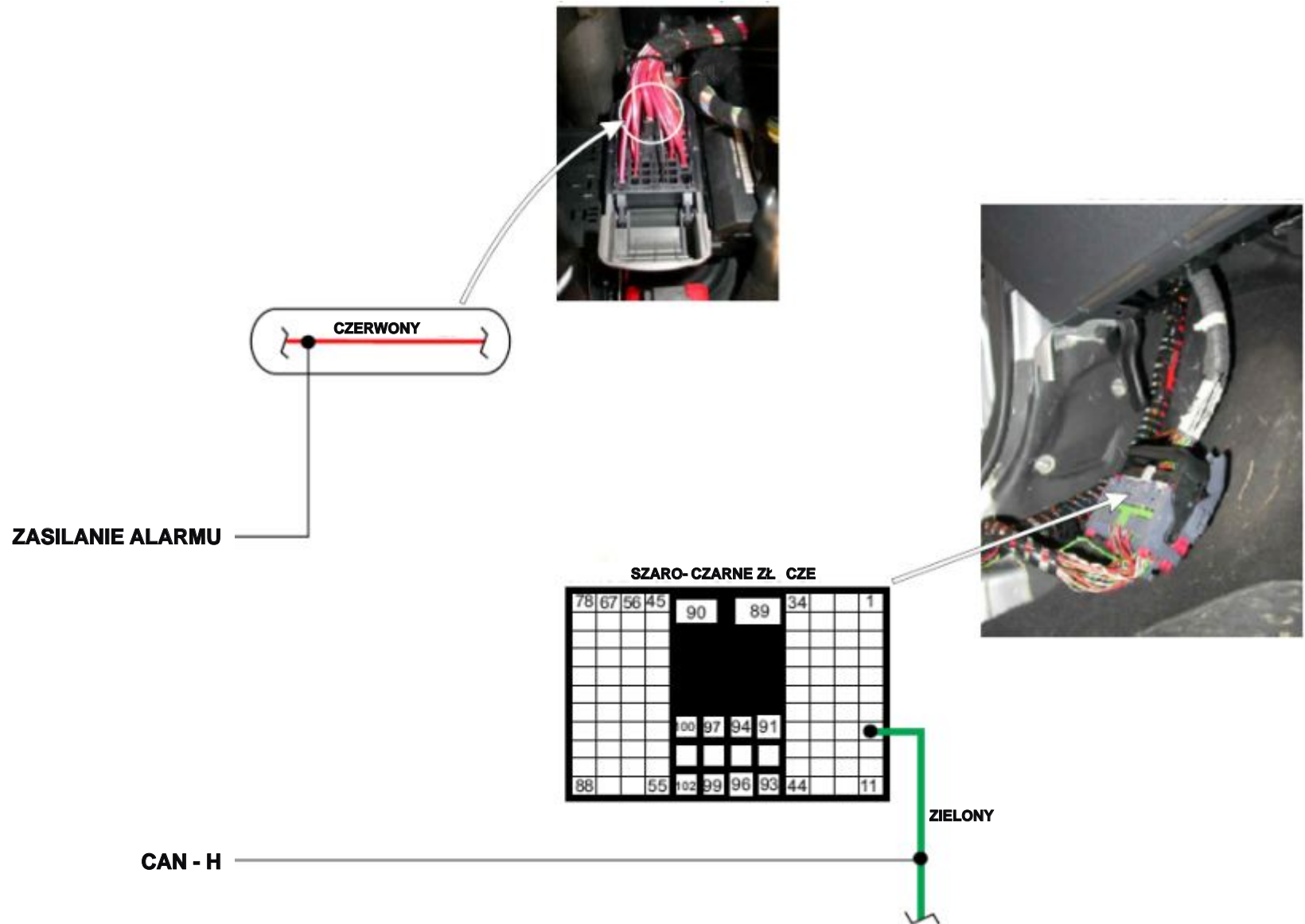



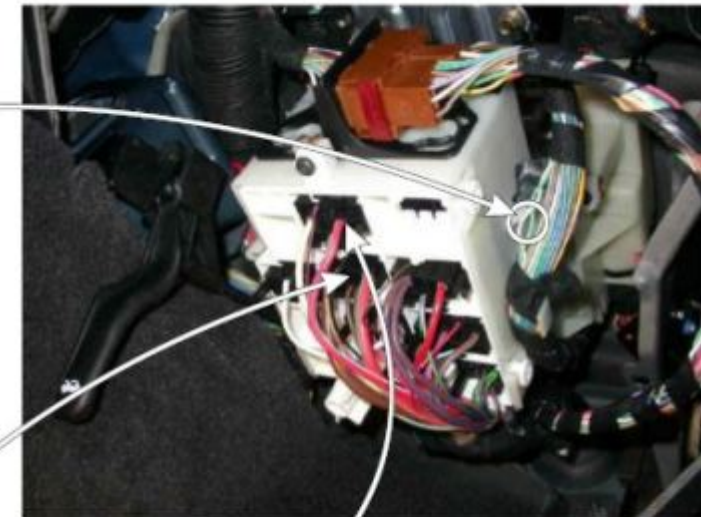
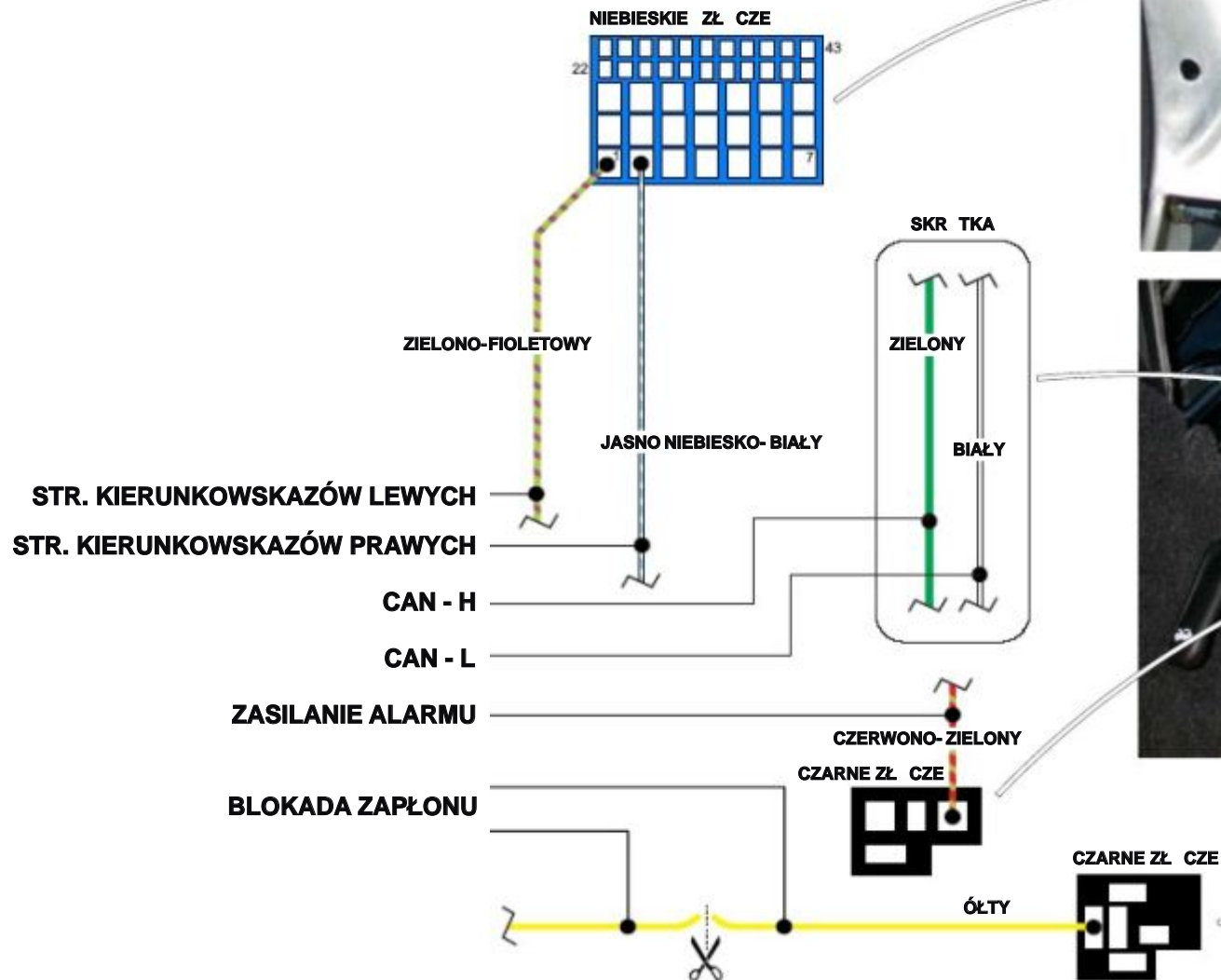

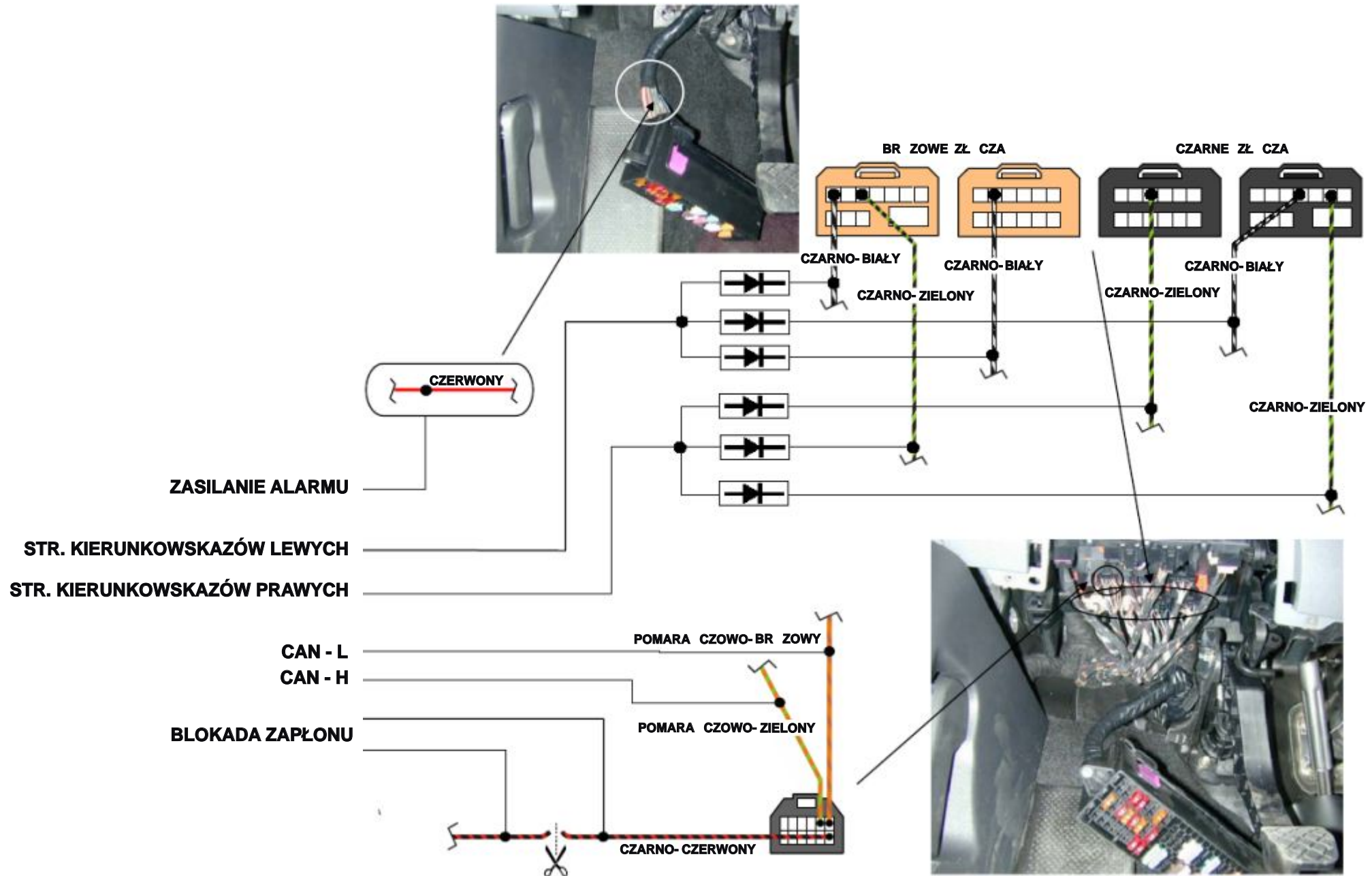

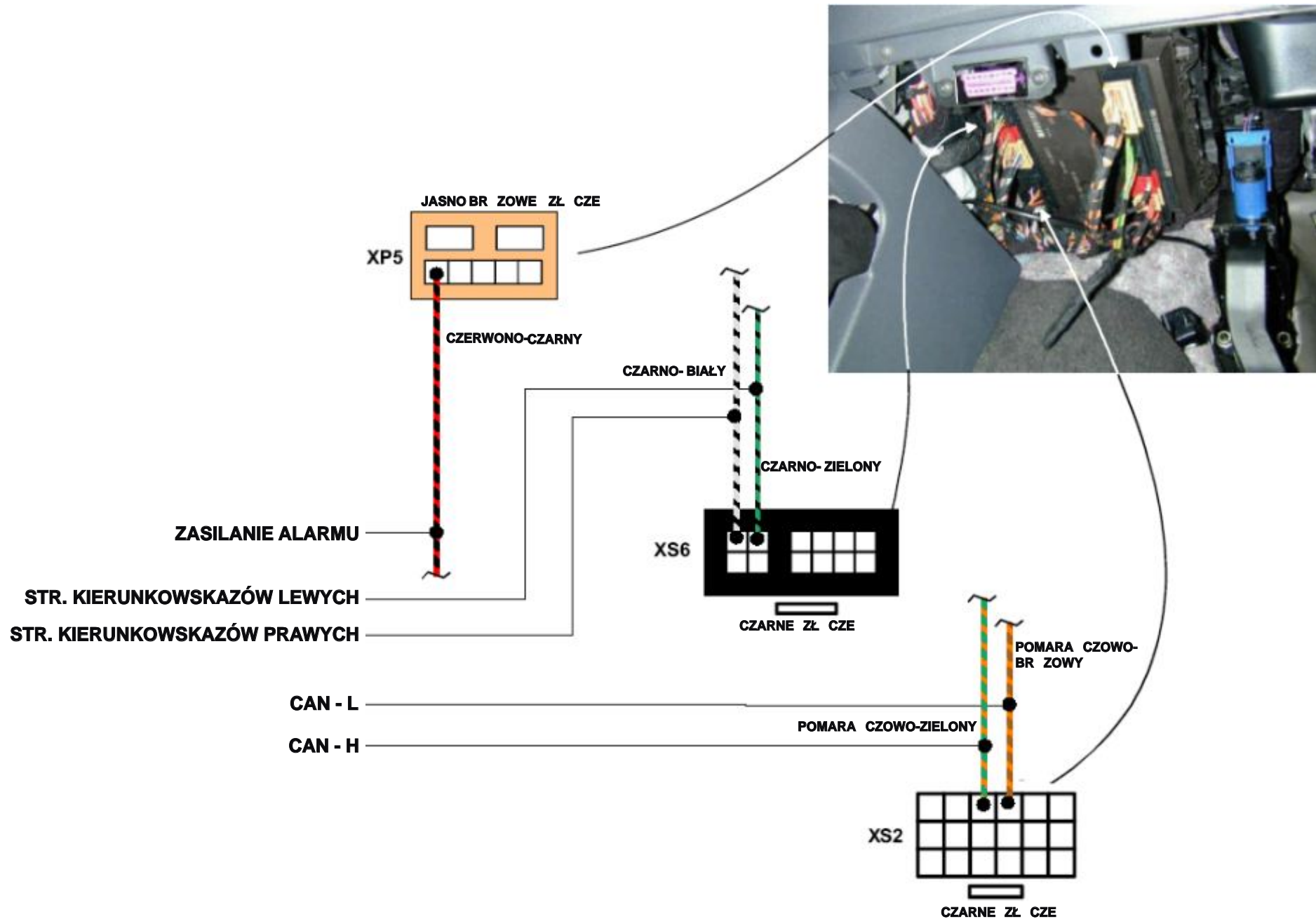



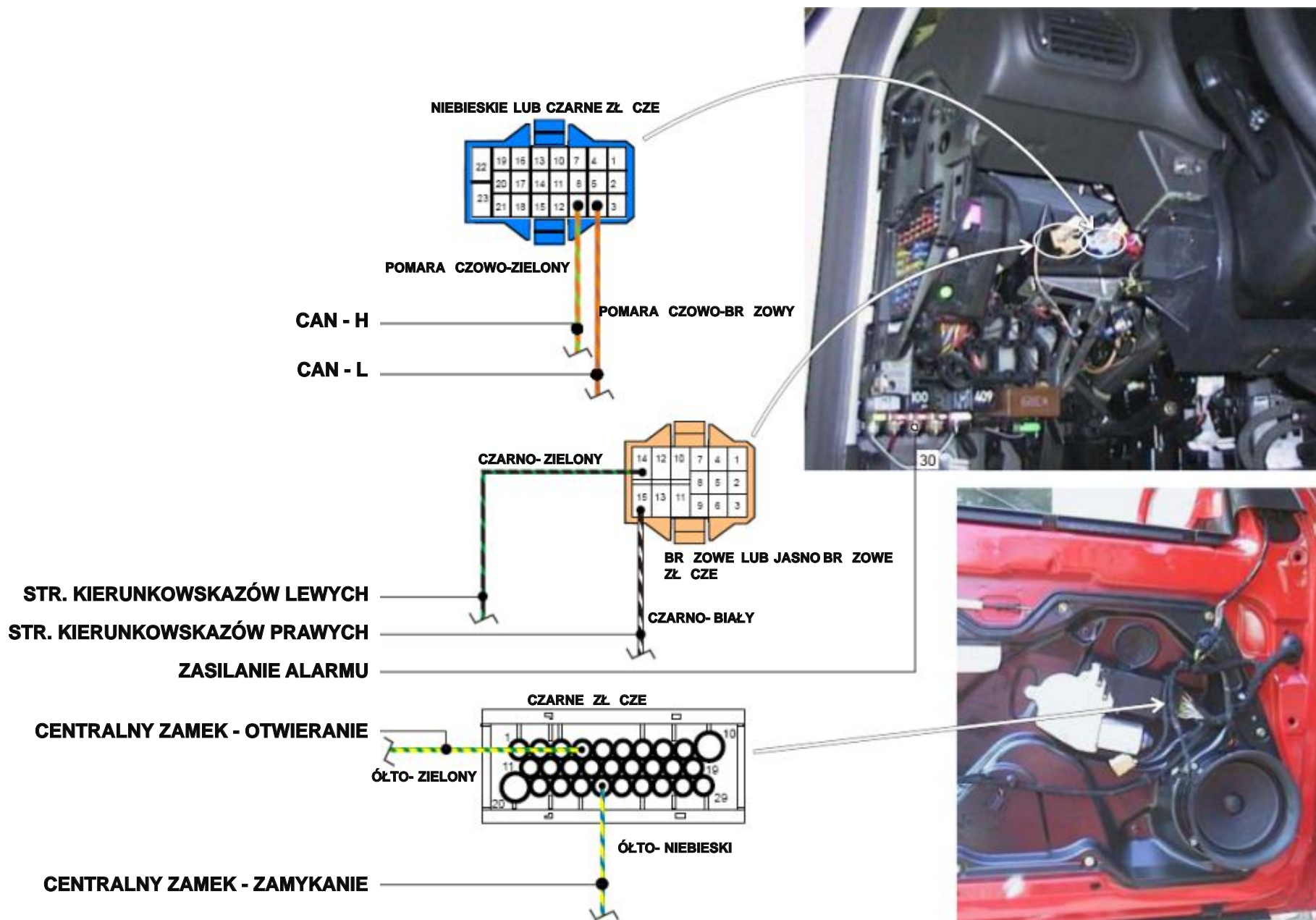



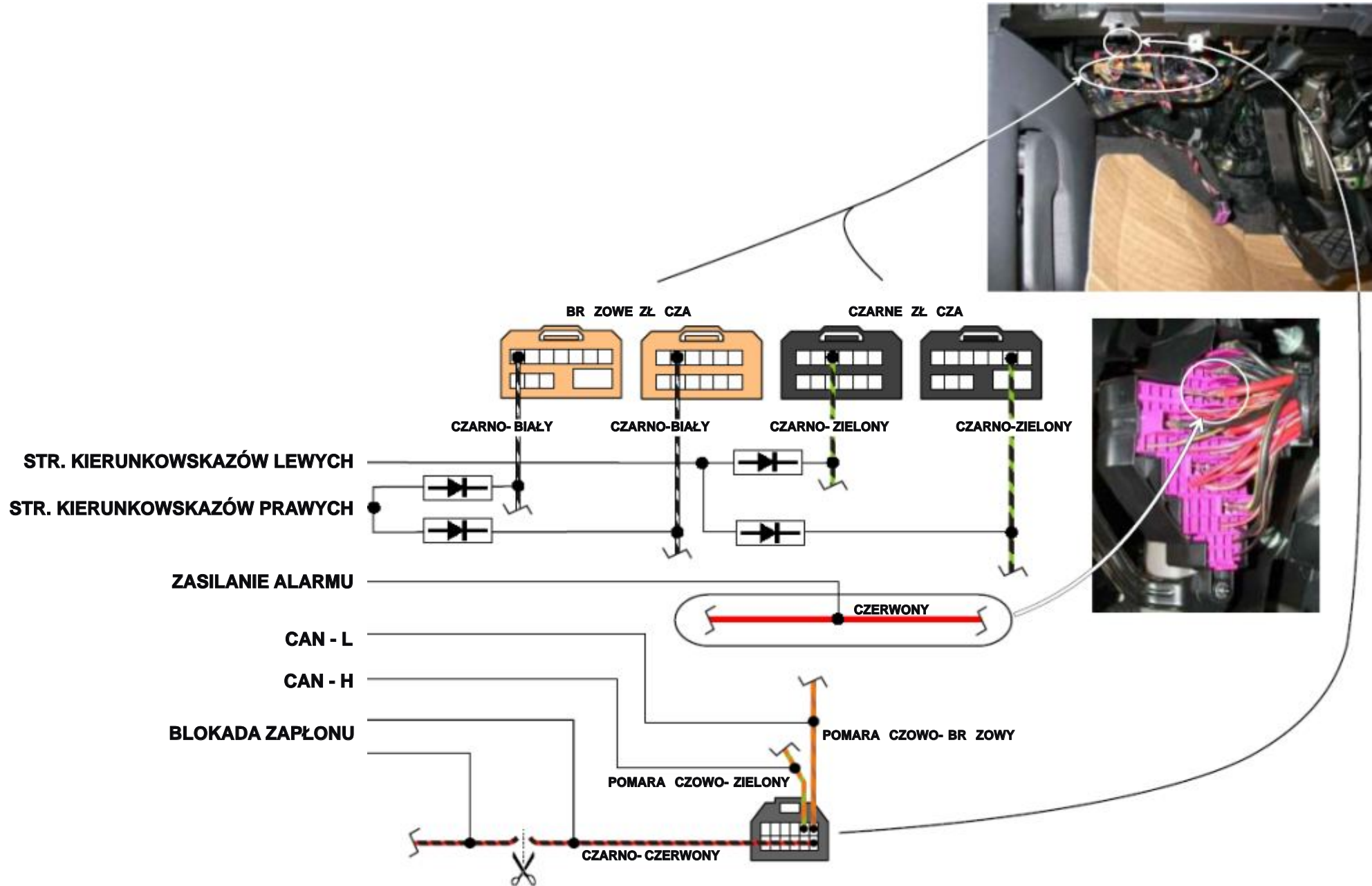

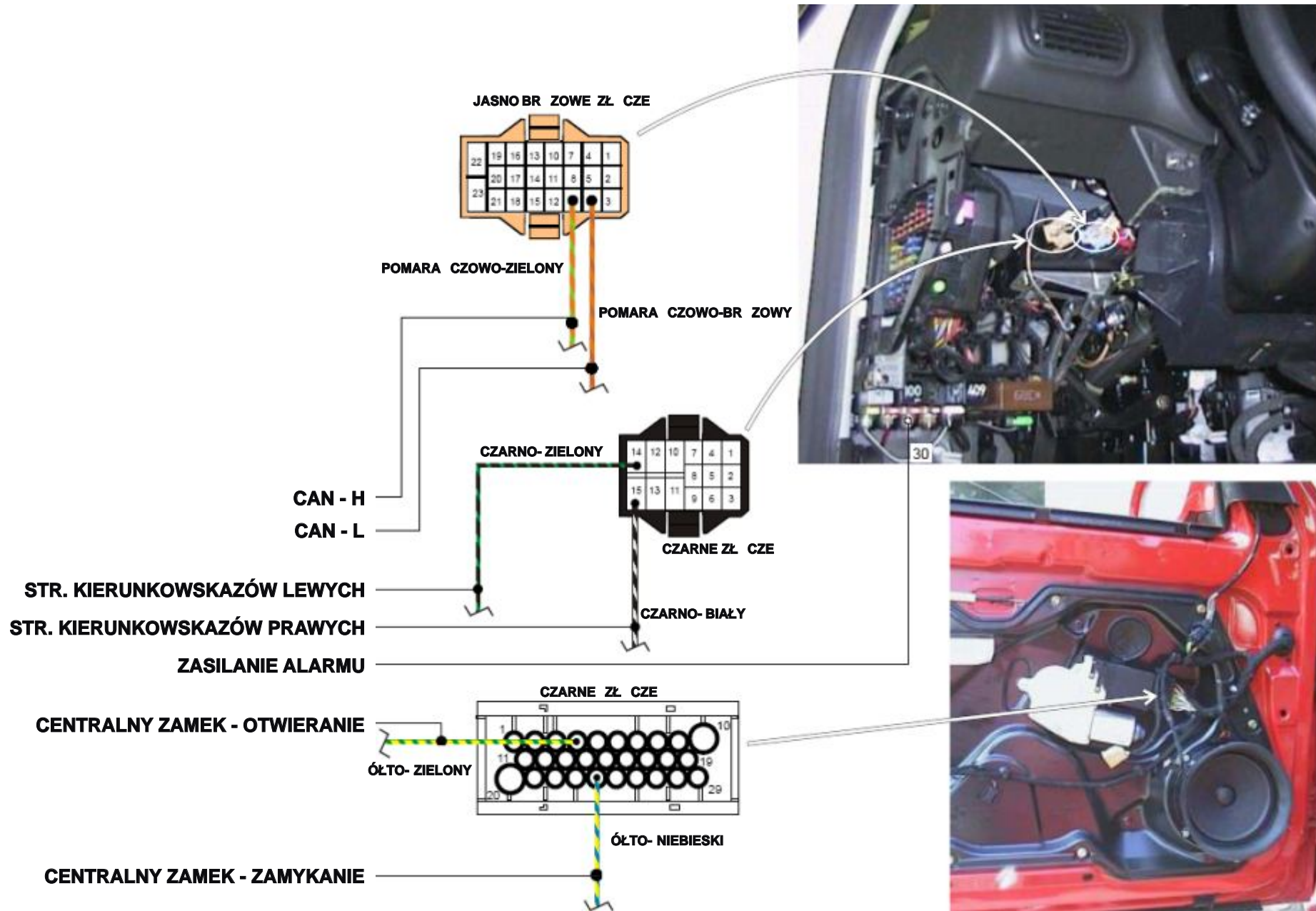

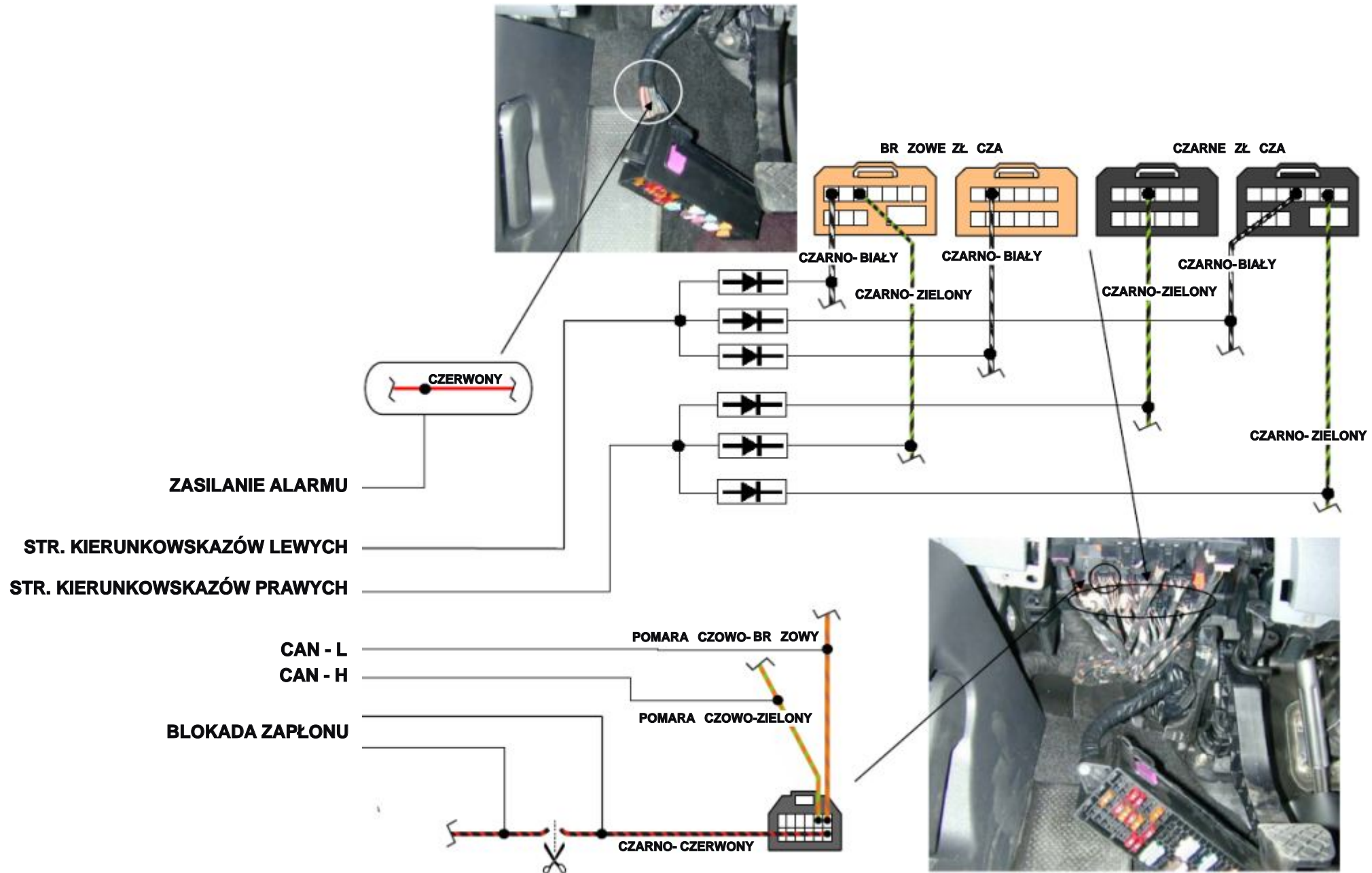



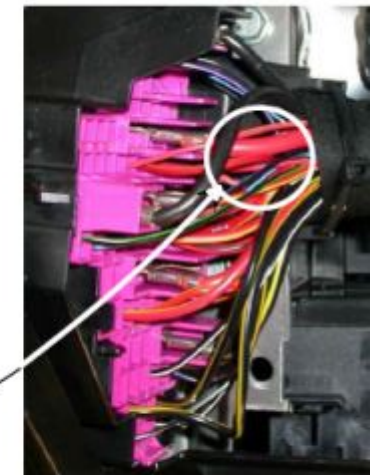
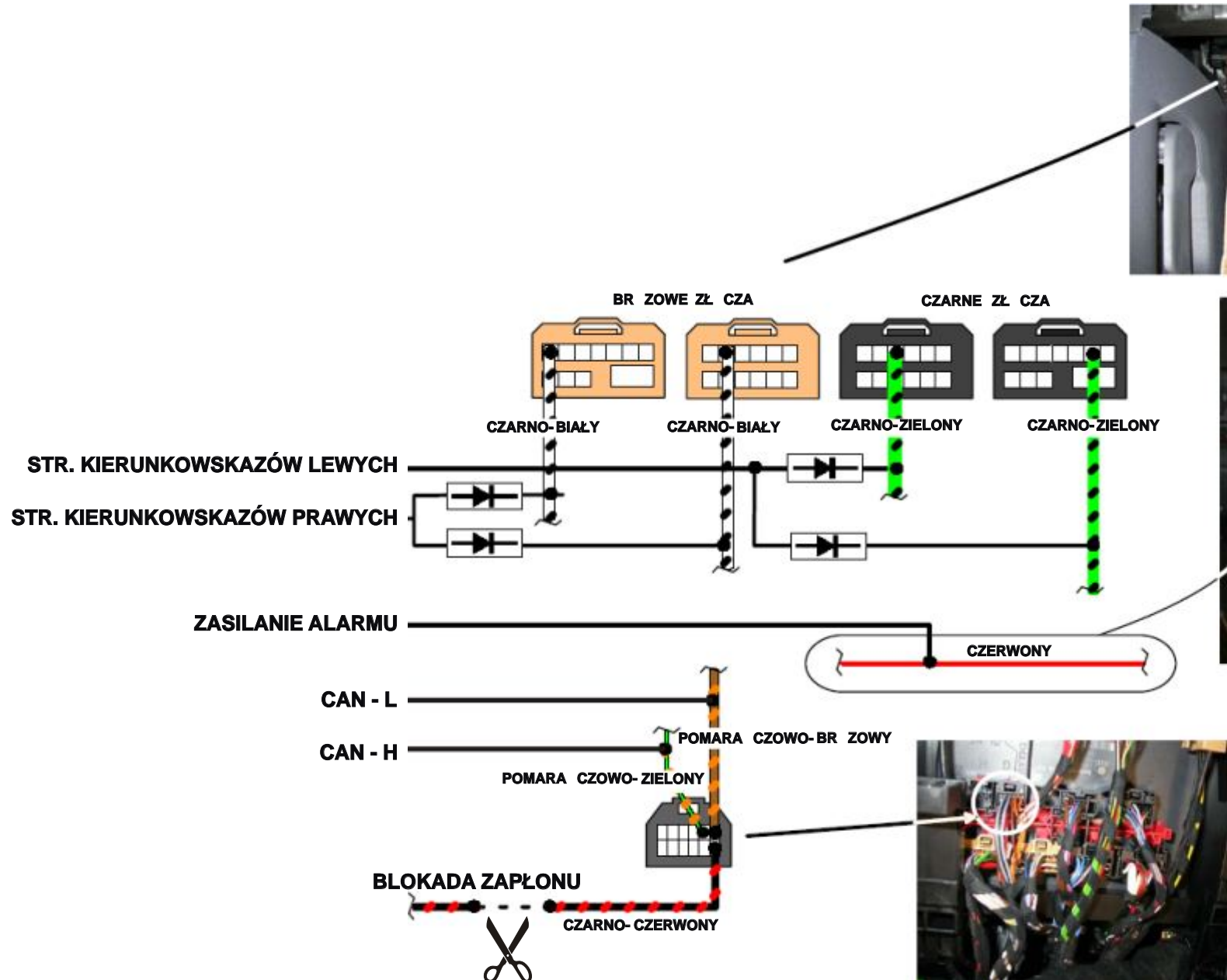



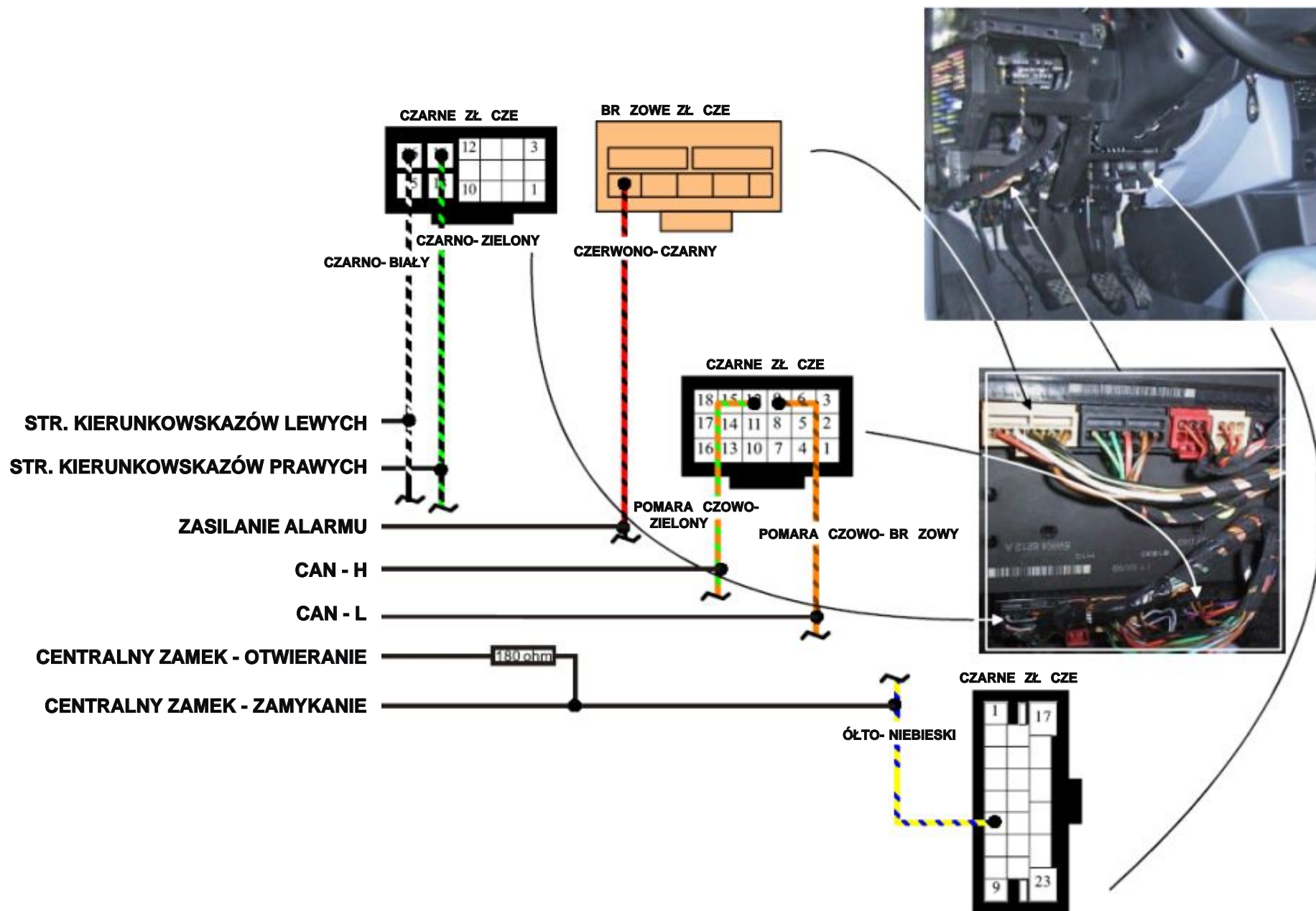

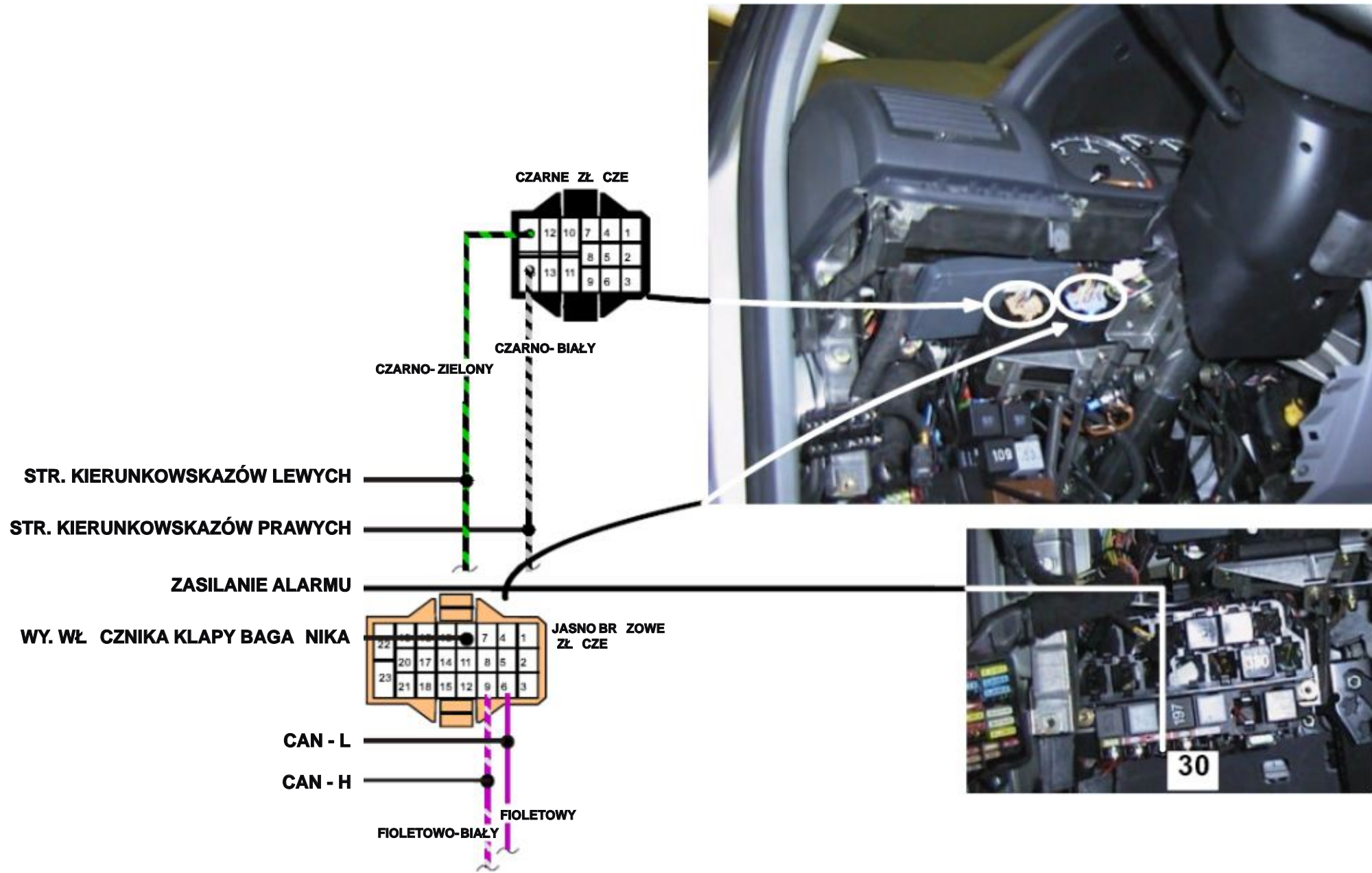

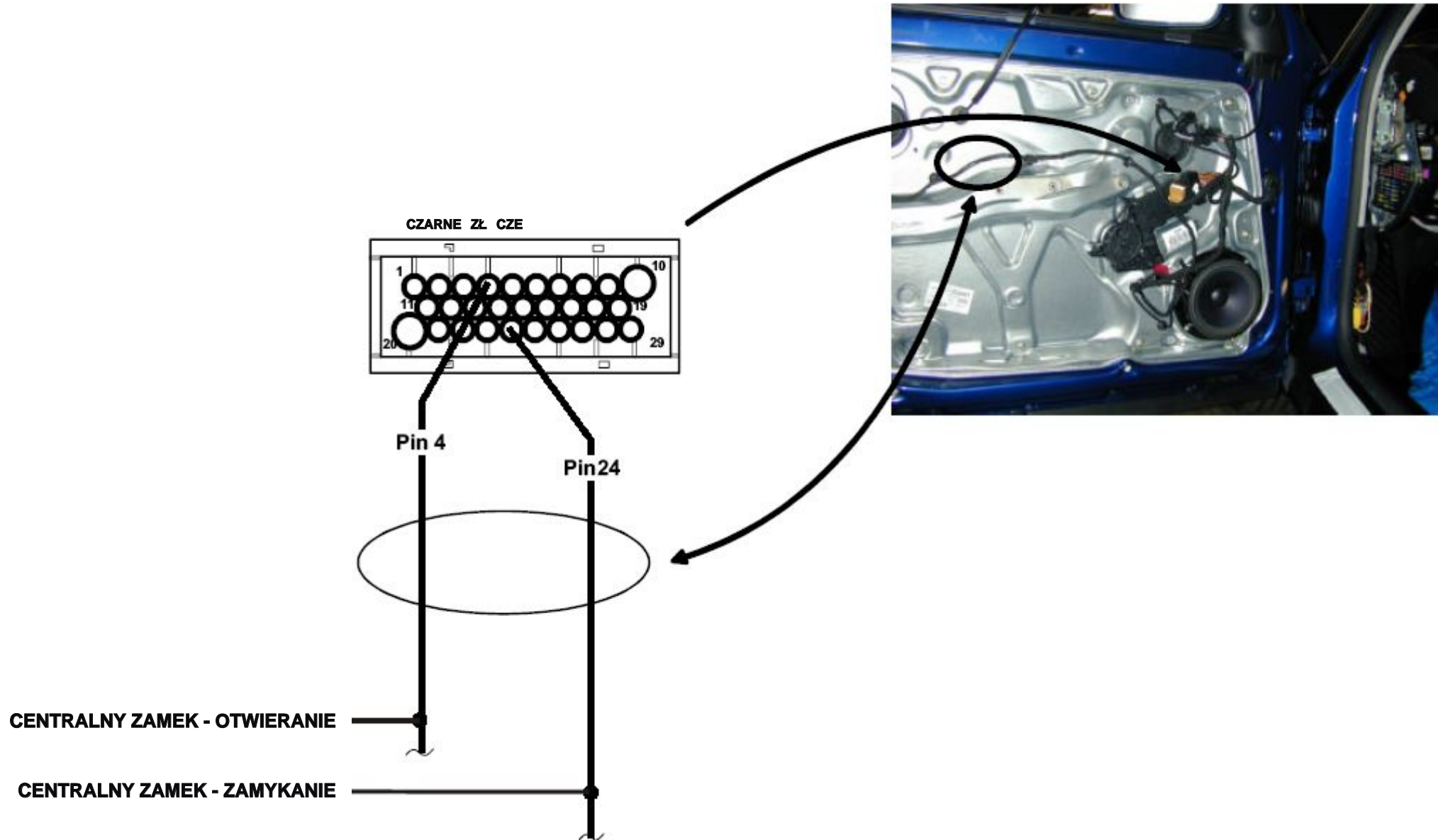



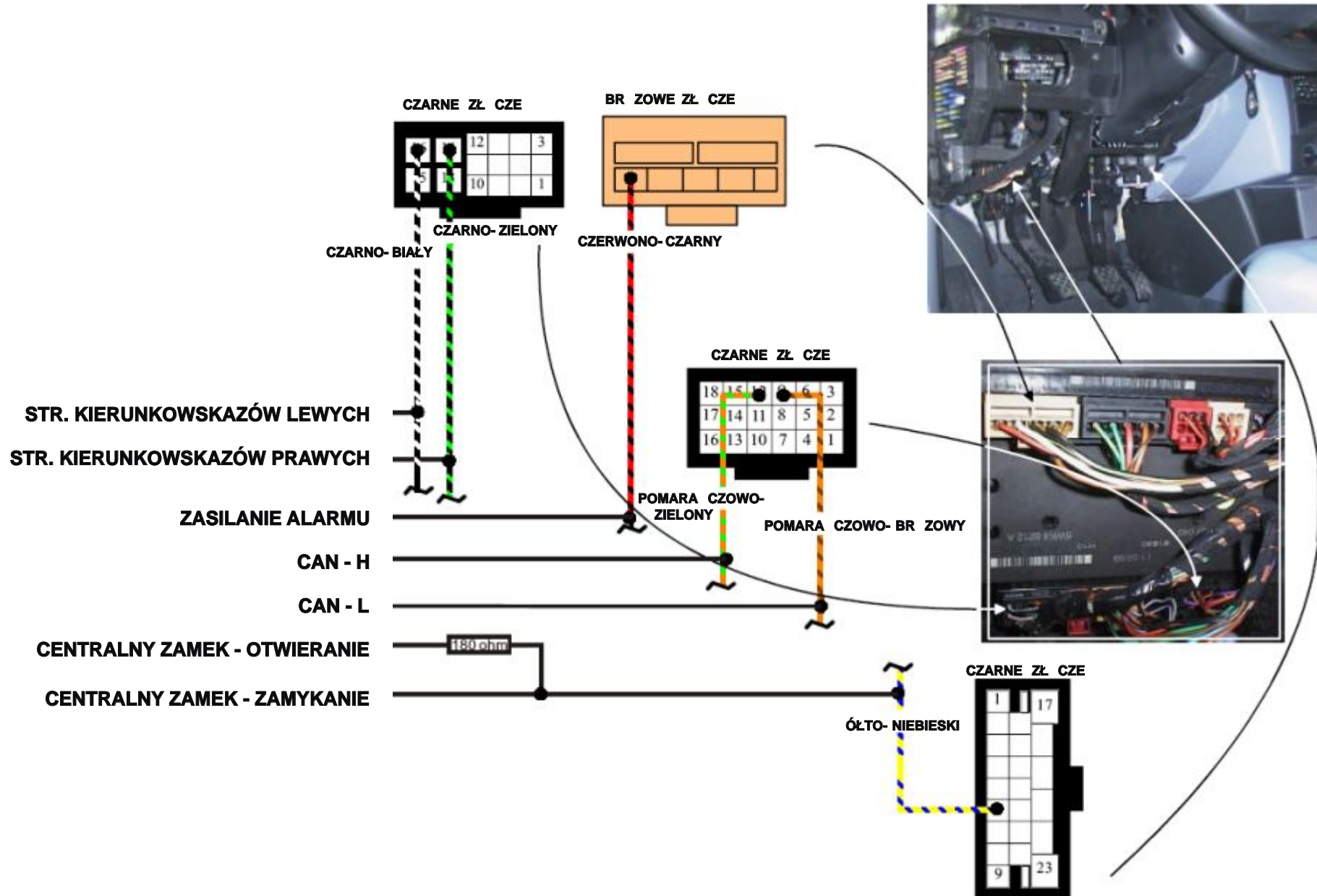



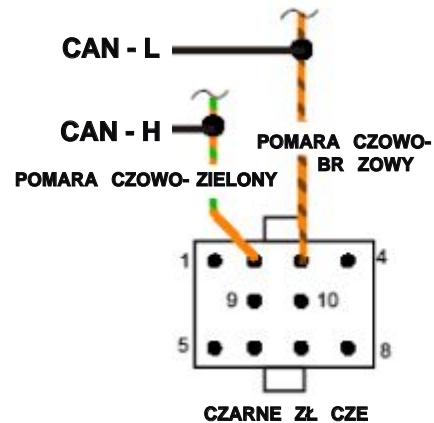
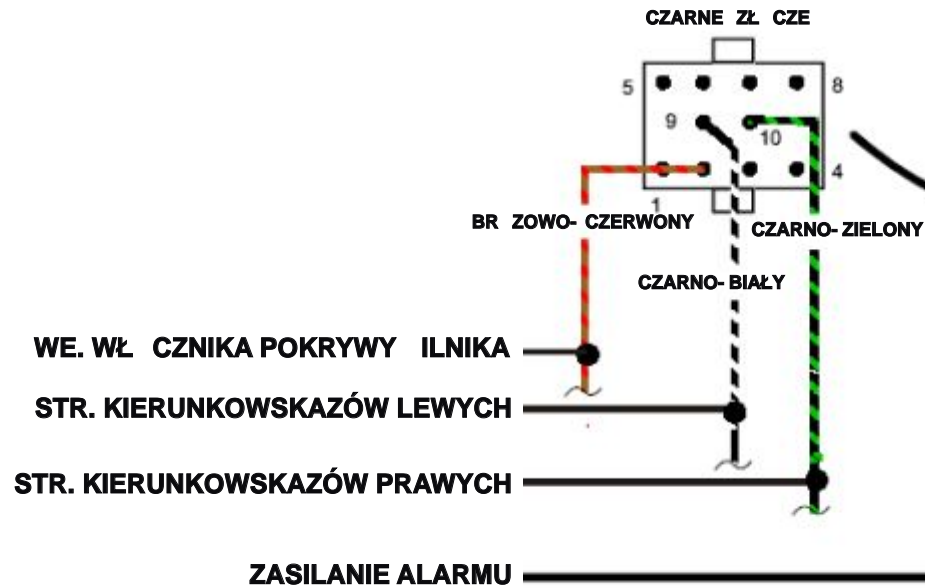

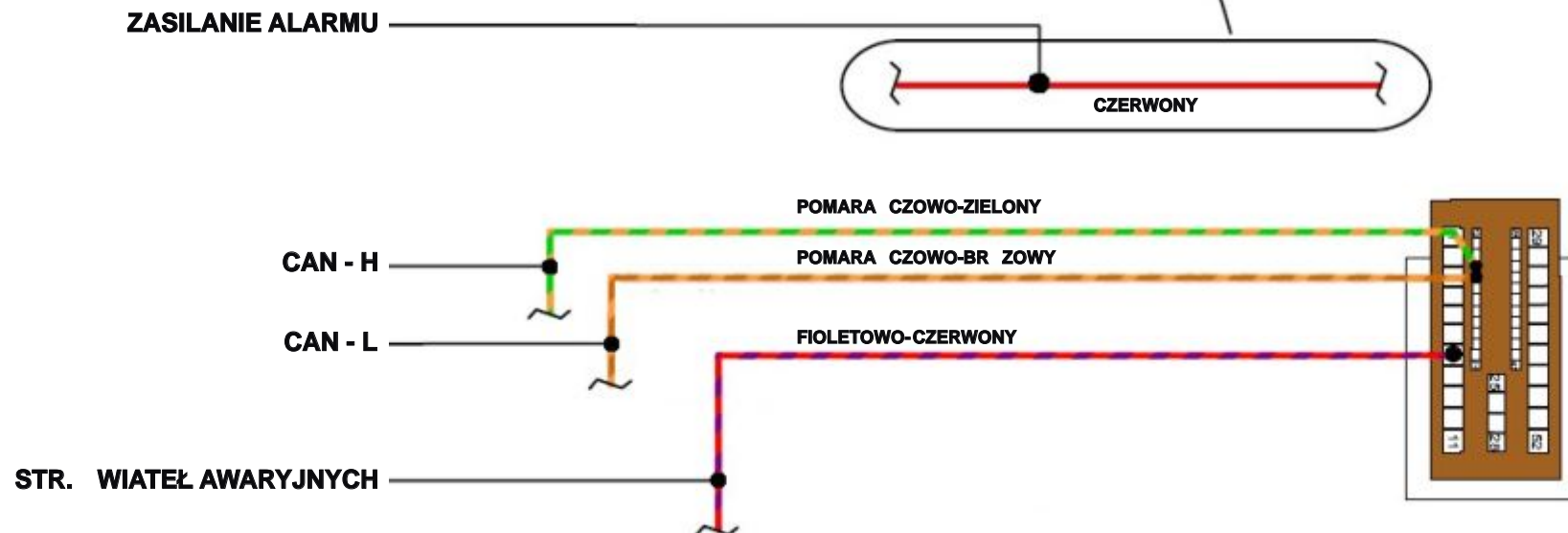

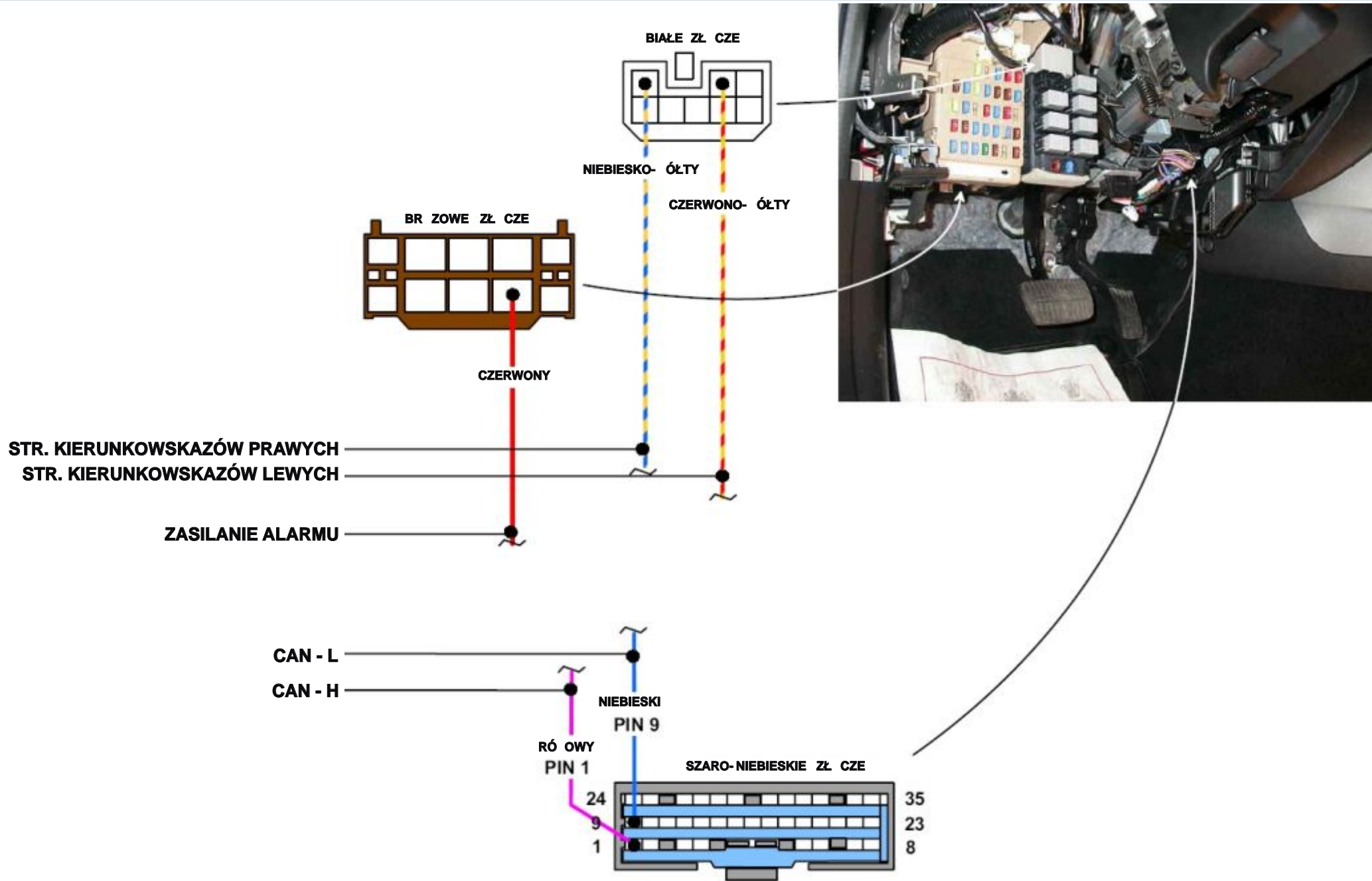

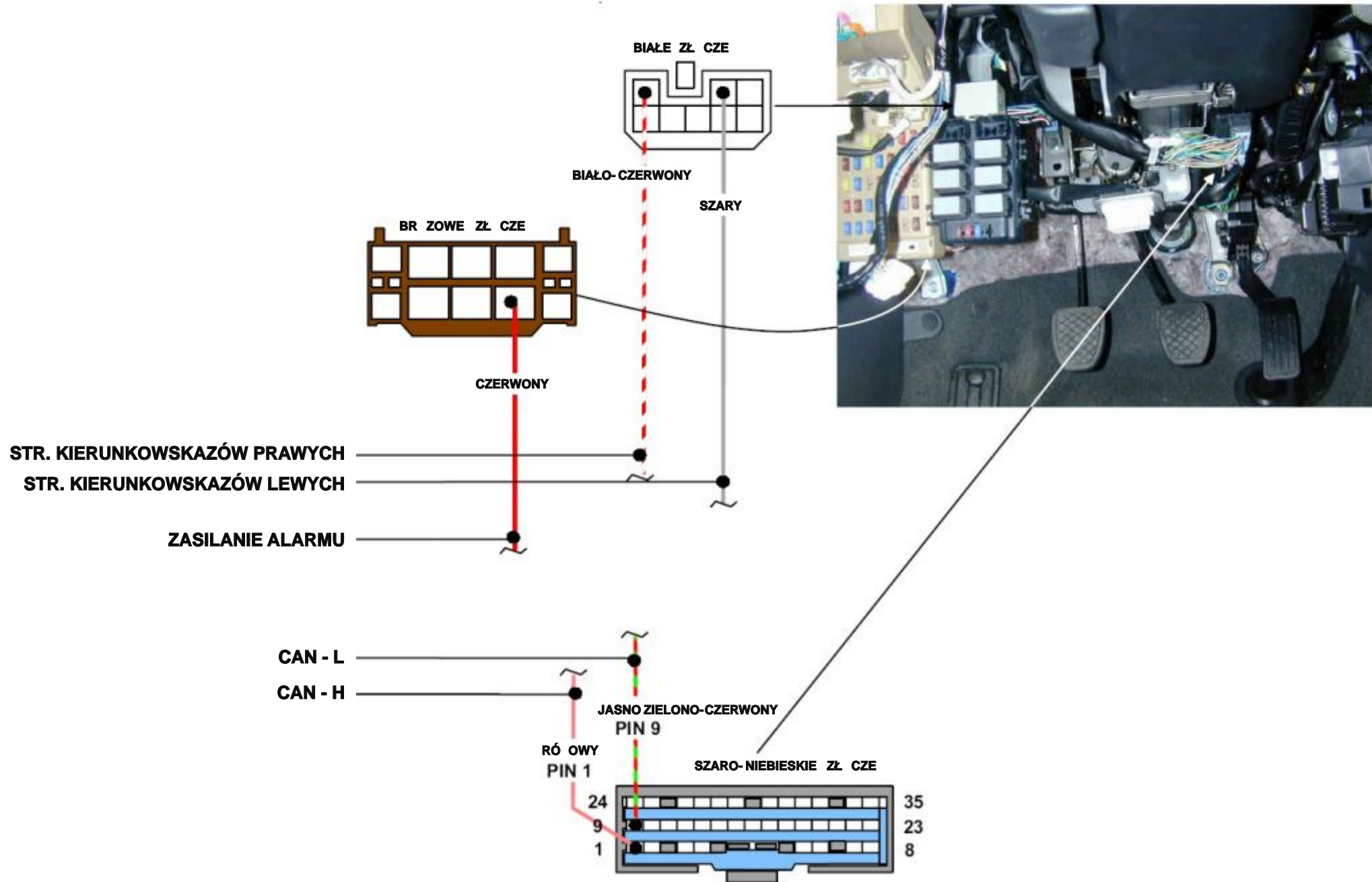



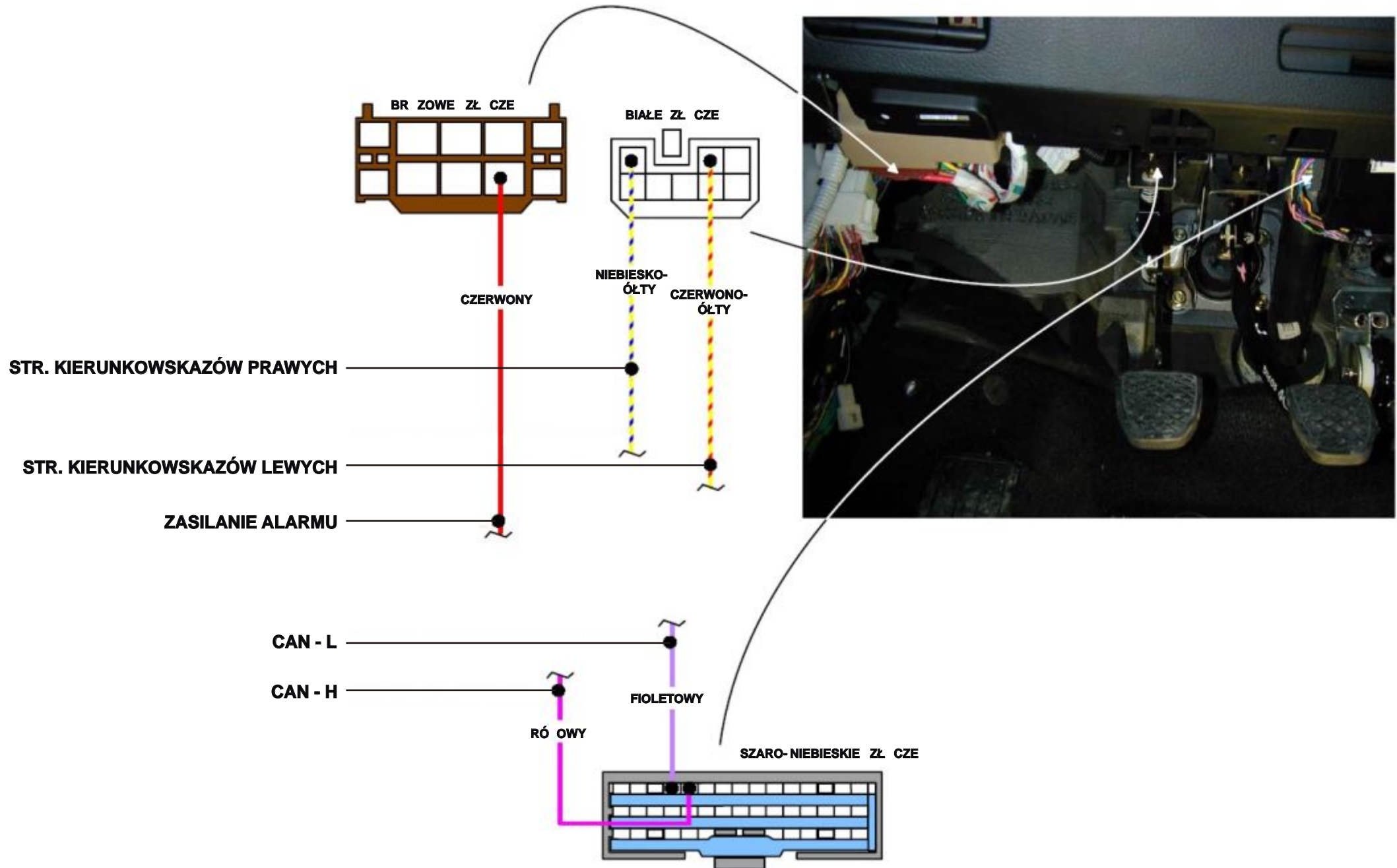

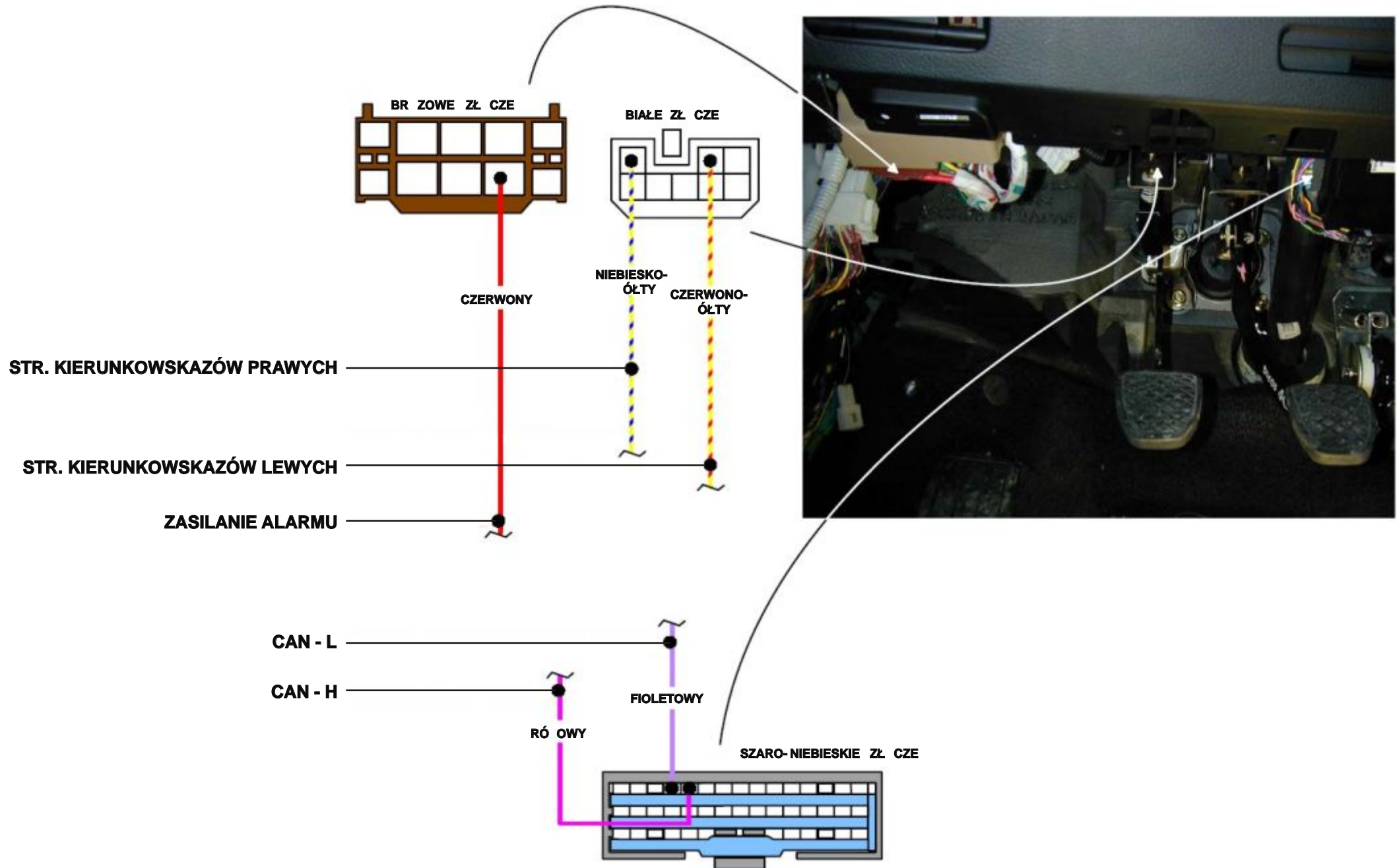

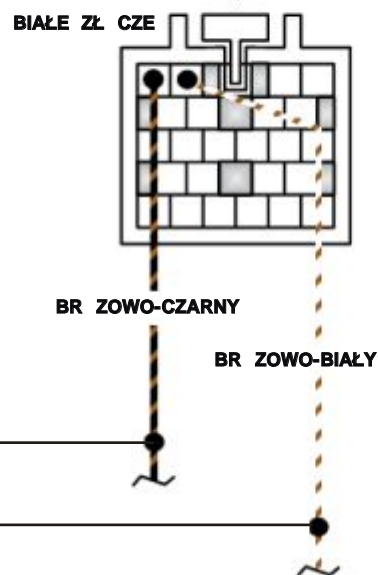

**CENTRALNY ZAMEK - OTWIERANIE**

**CENTRALNY ZAMEK - ZAMYKANIE**



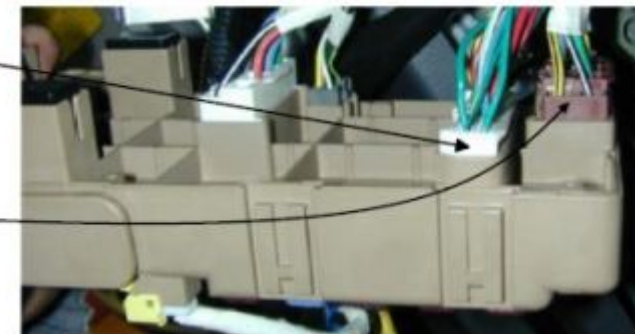
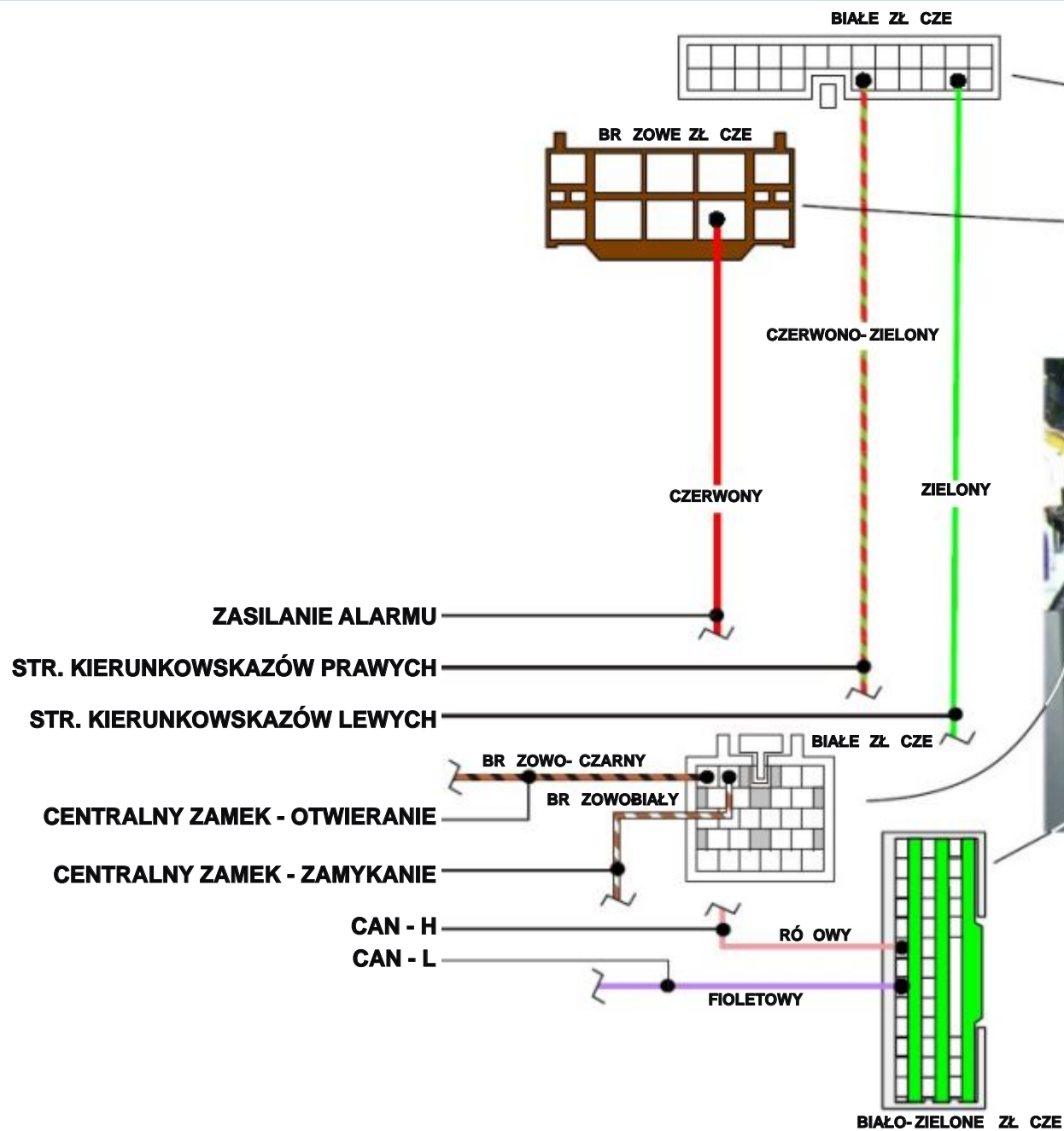



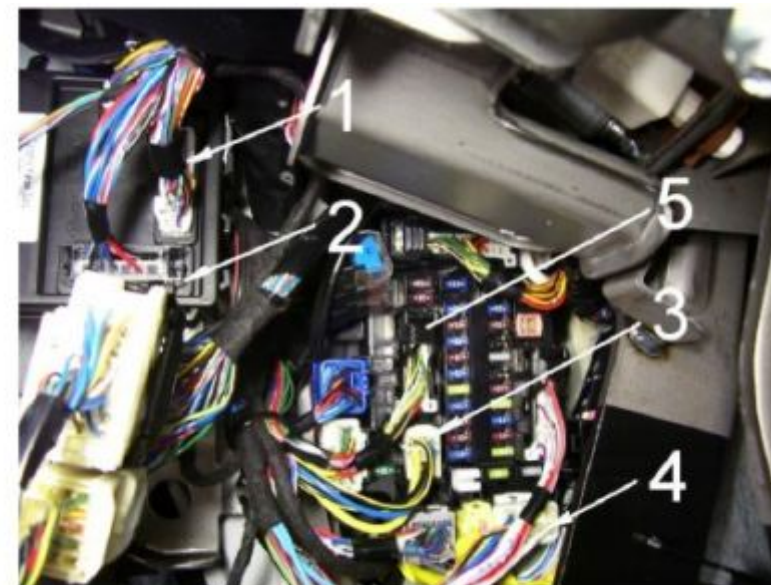
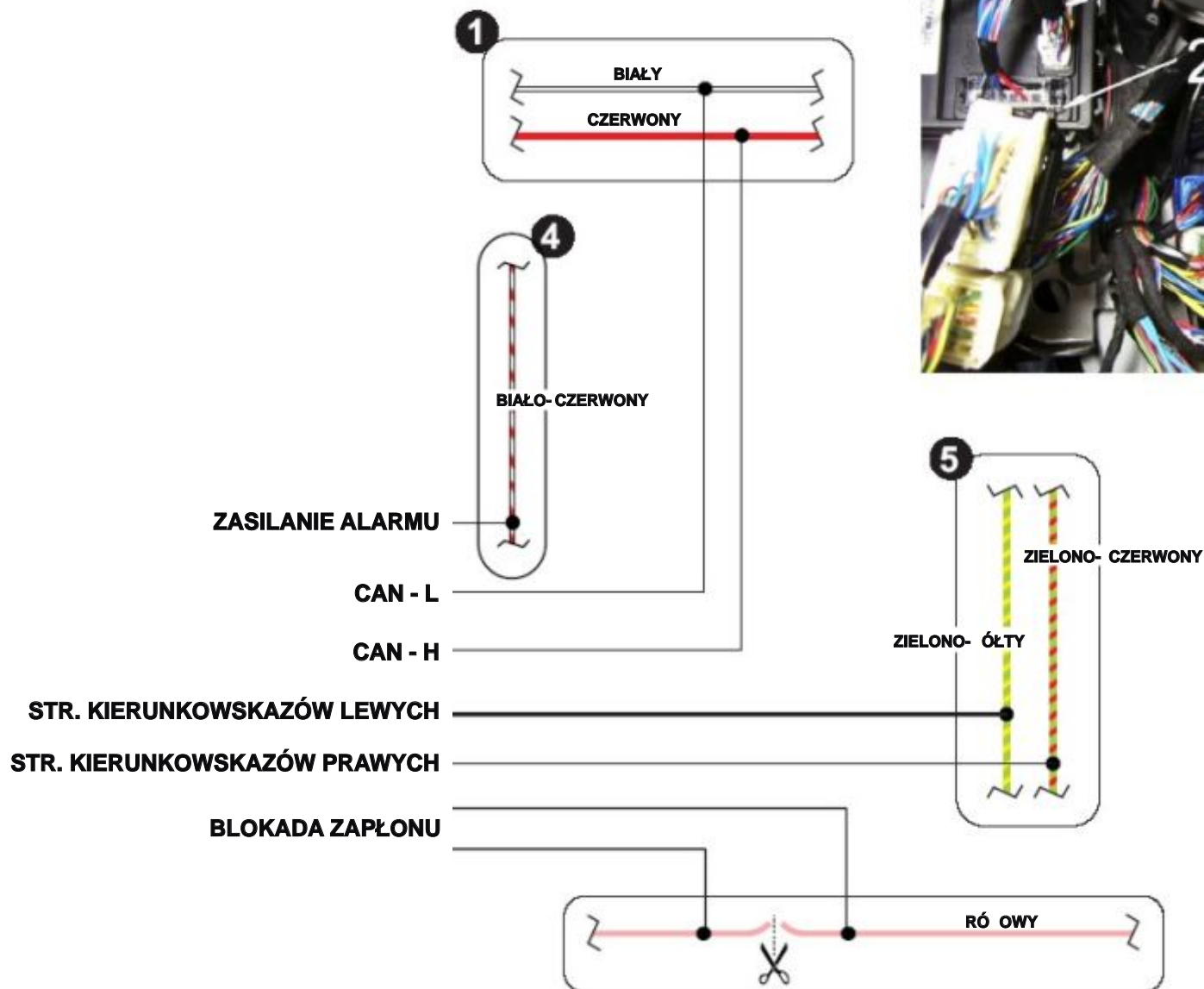

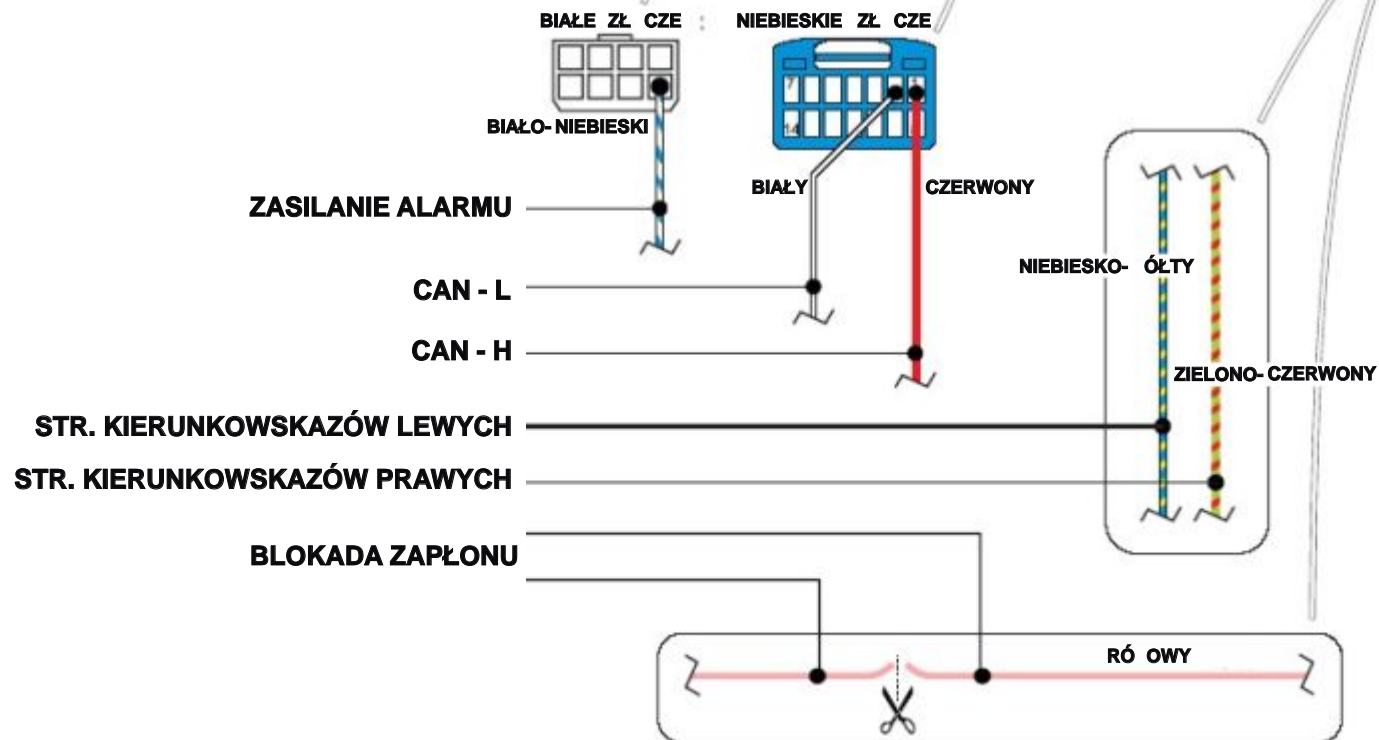
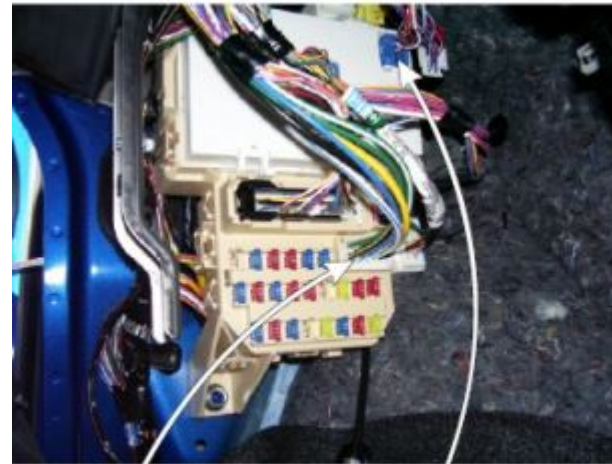

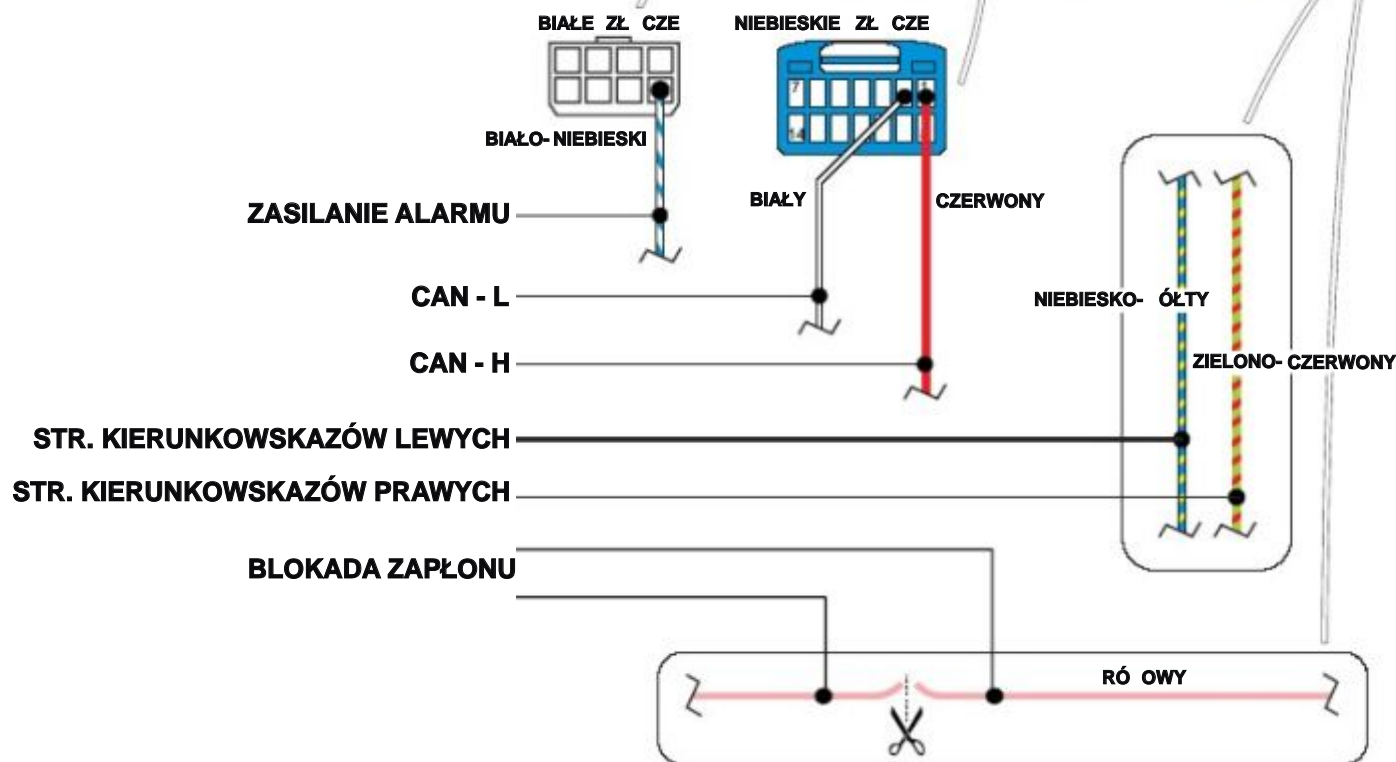

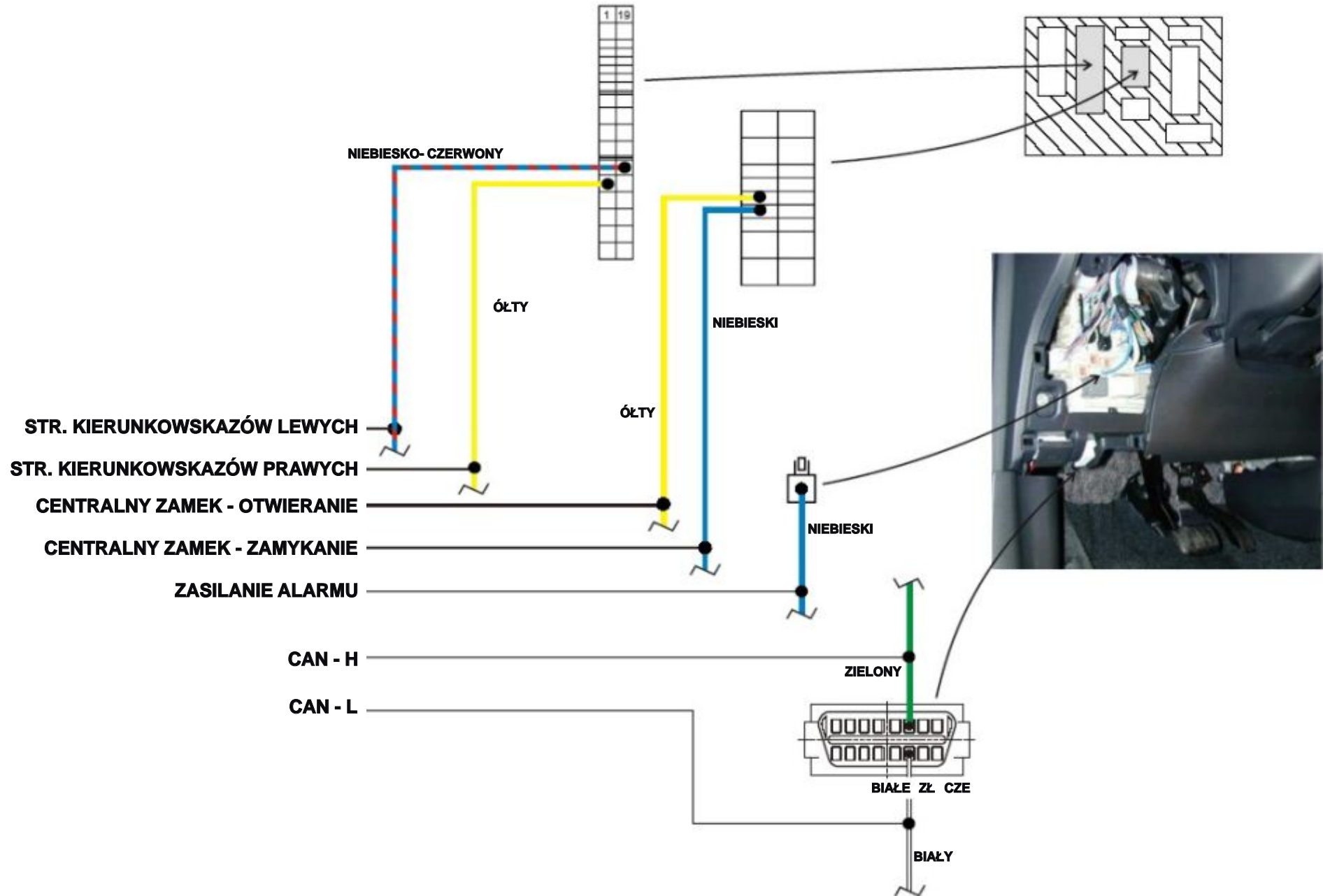



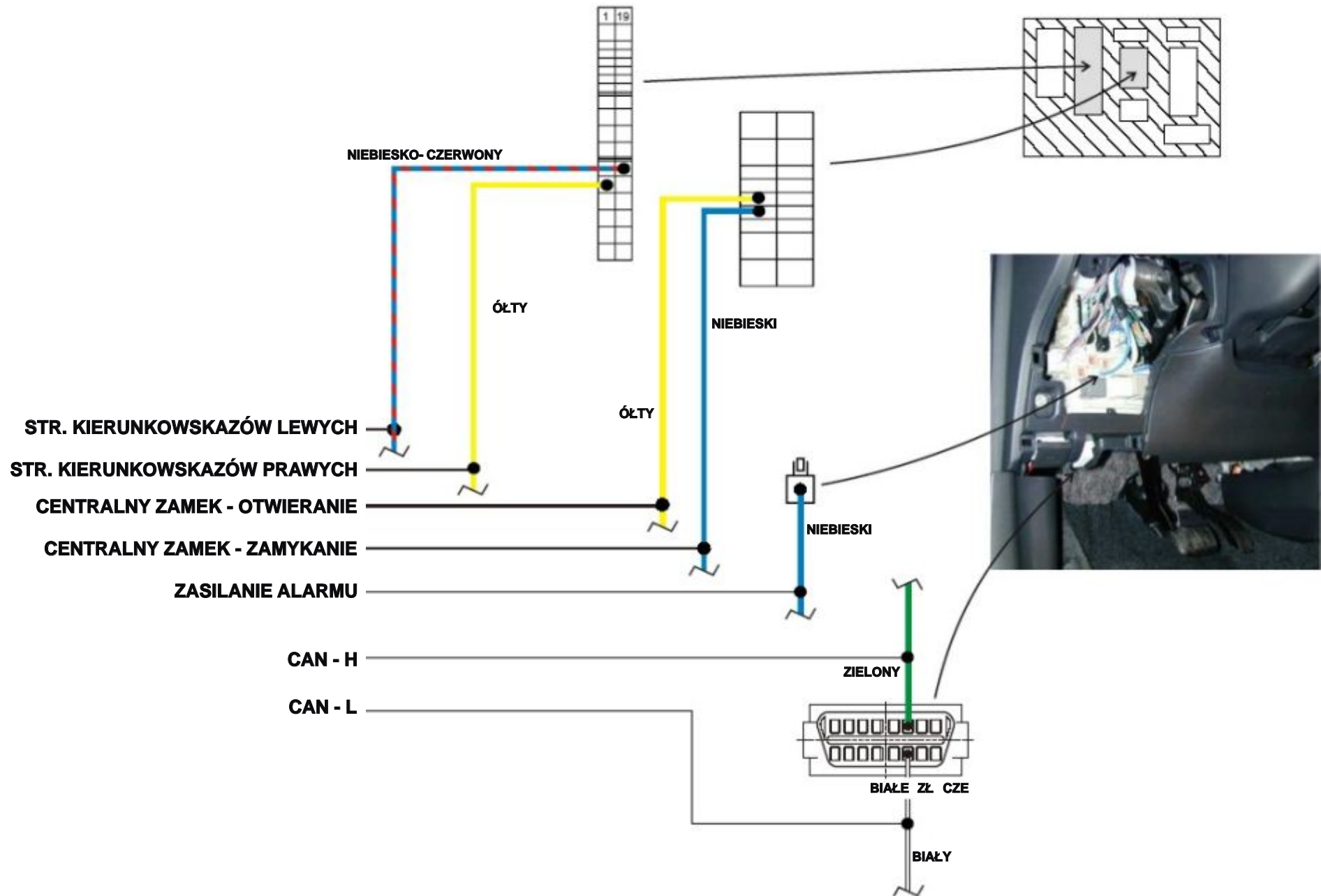

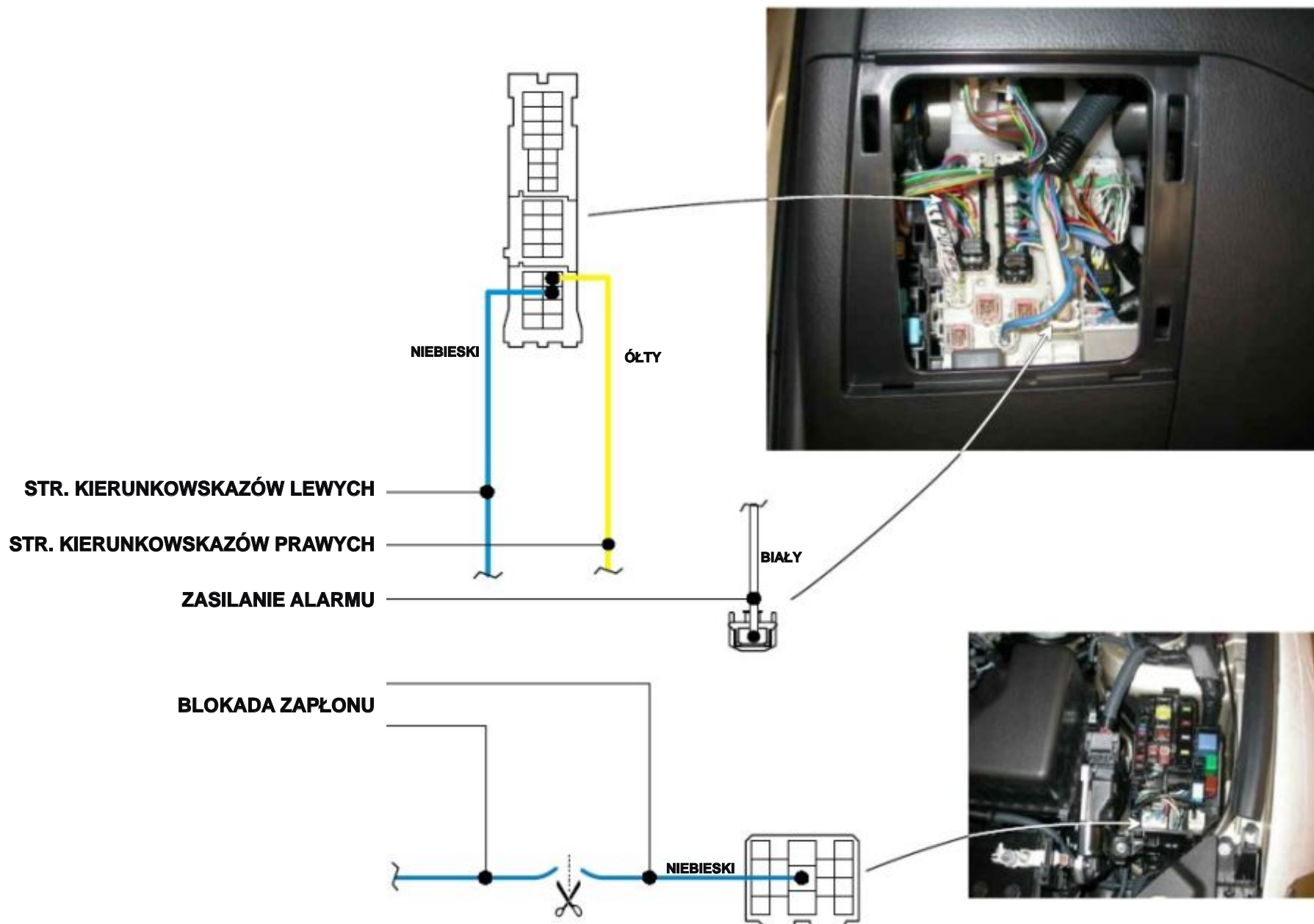

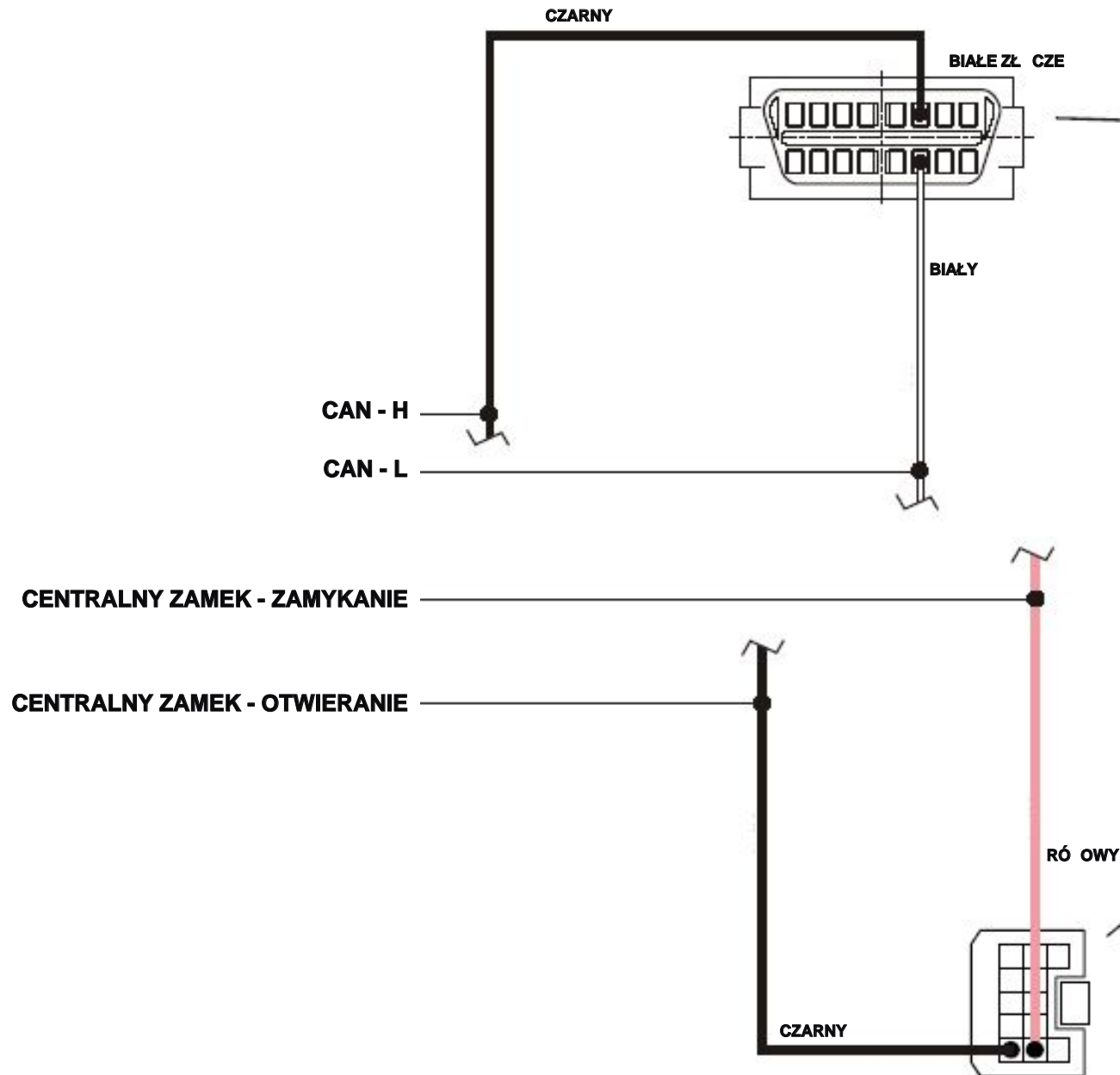

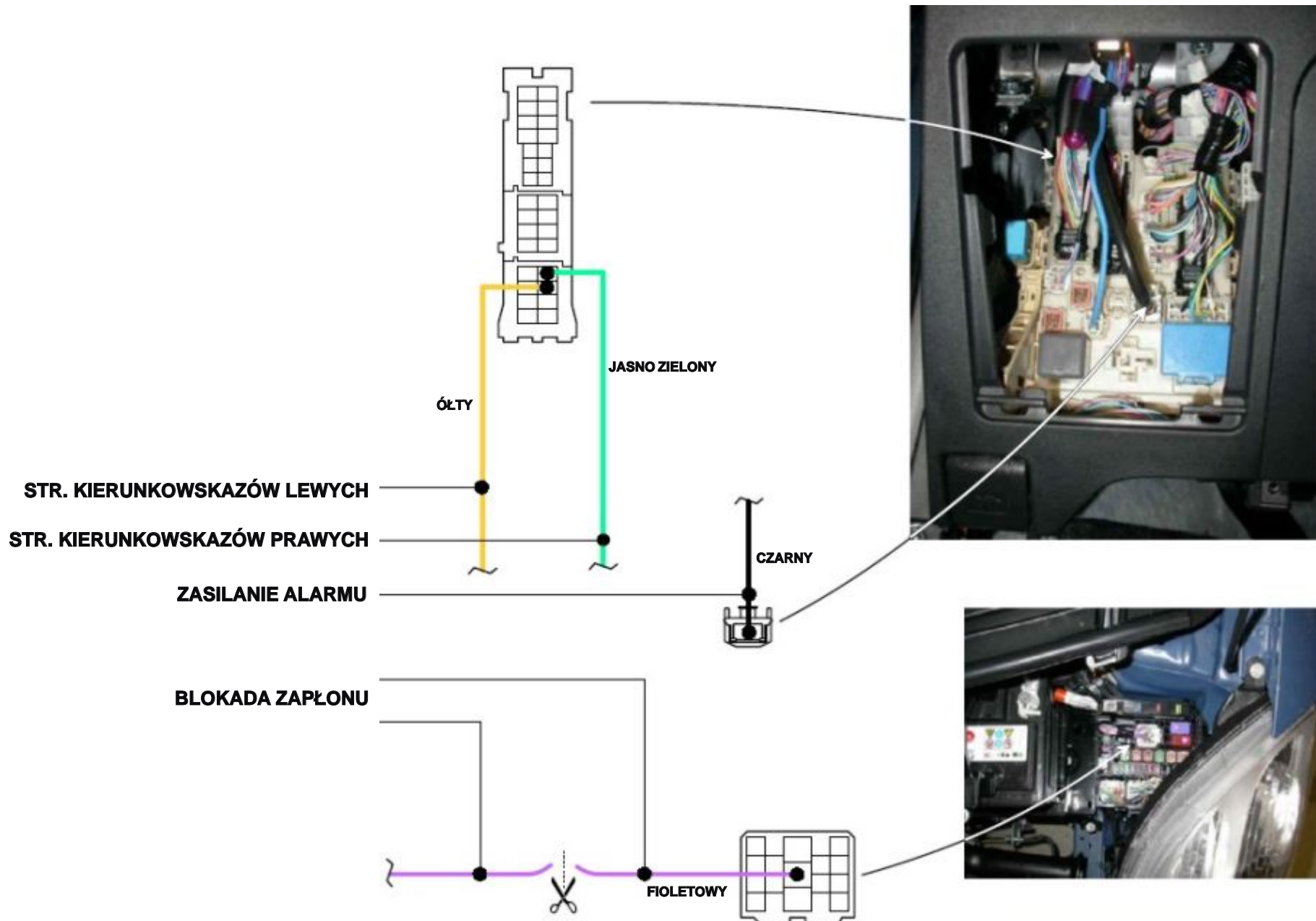



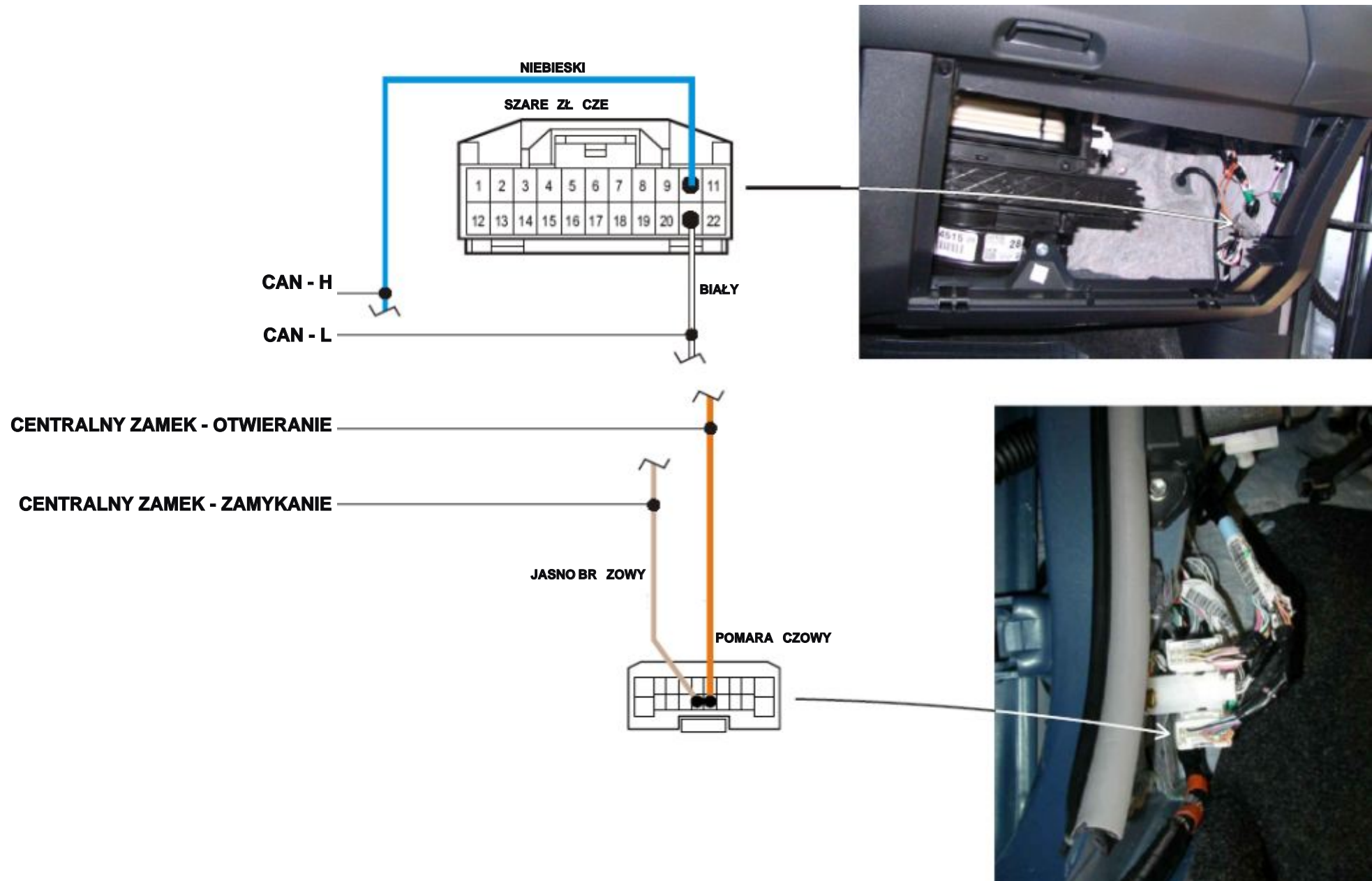



ZASILANIE ALARMU

STR. KIERUNKOWSKAZÓW LEWYCH  
STR. KIERUNKOWSKAZÓW PRAWYCH

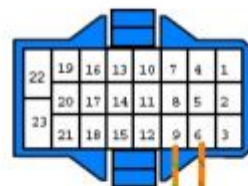
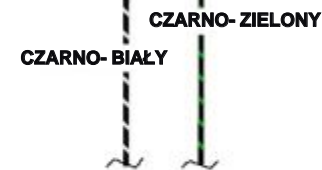
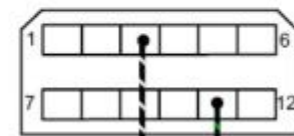

NIEBIESKIE  
ZŁ CZE

CAN - L

CAN - H

POMARA CZOWO-ZIELONY  
POMARA CZOWO-BR ZOWY



**CENTRALNY ZAMEK - OTWIERANIE**

ÓŁTO- ZIELONY

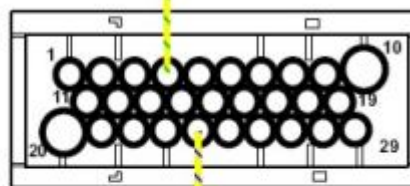

**CZARNE  
ZŁ. CZE**

**CENTRALNY ZAMEK - ZAMYKANIE**

ÓŁTO- NIEBIESKI

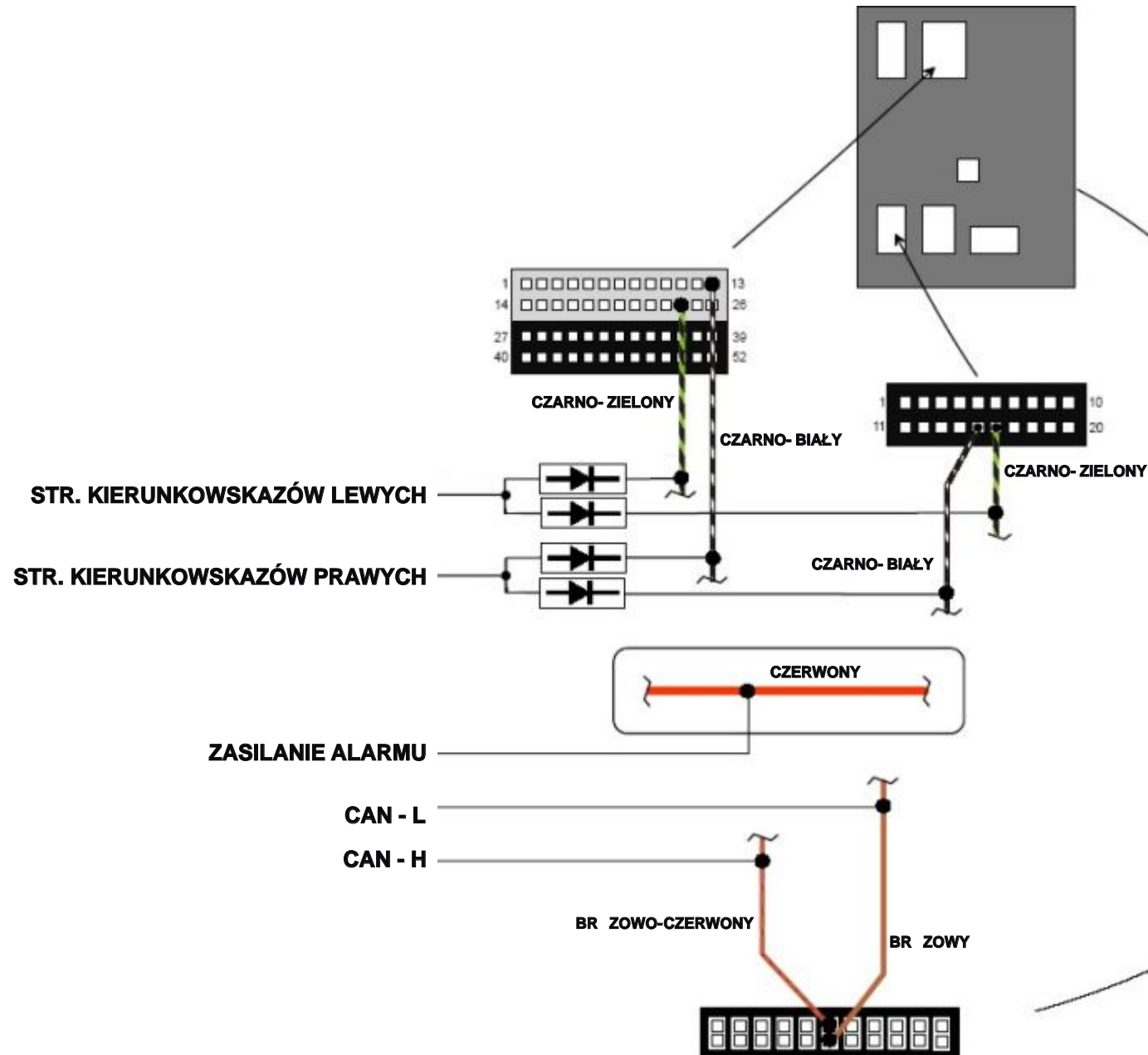



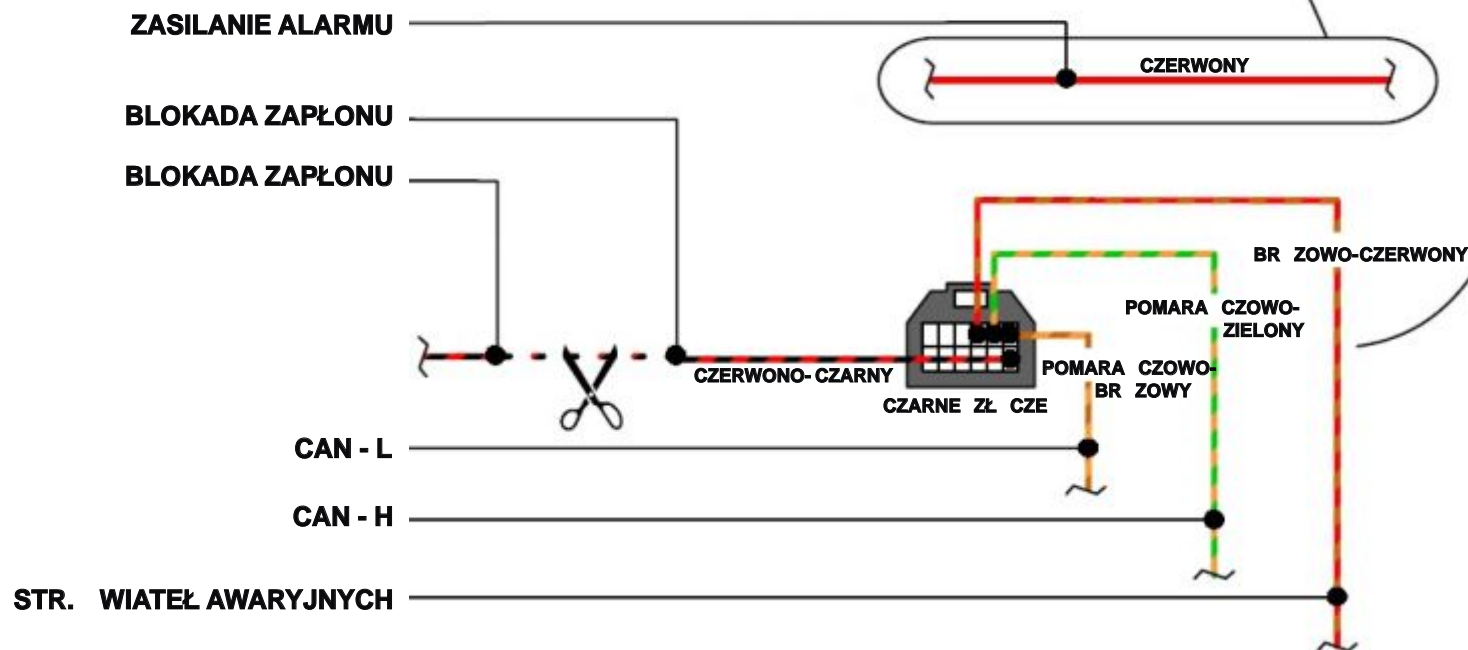

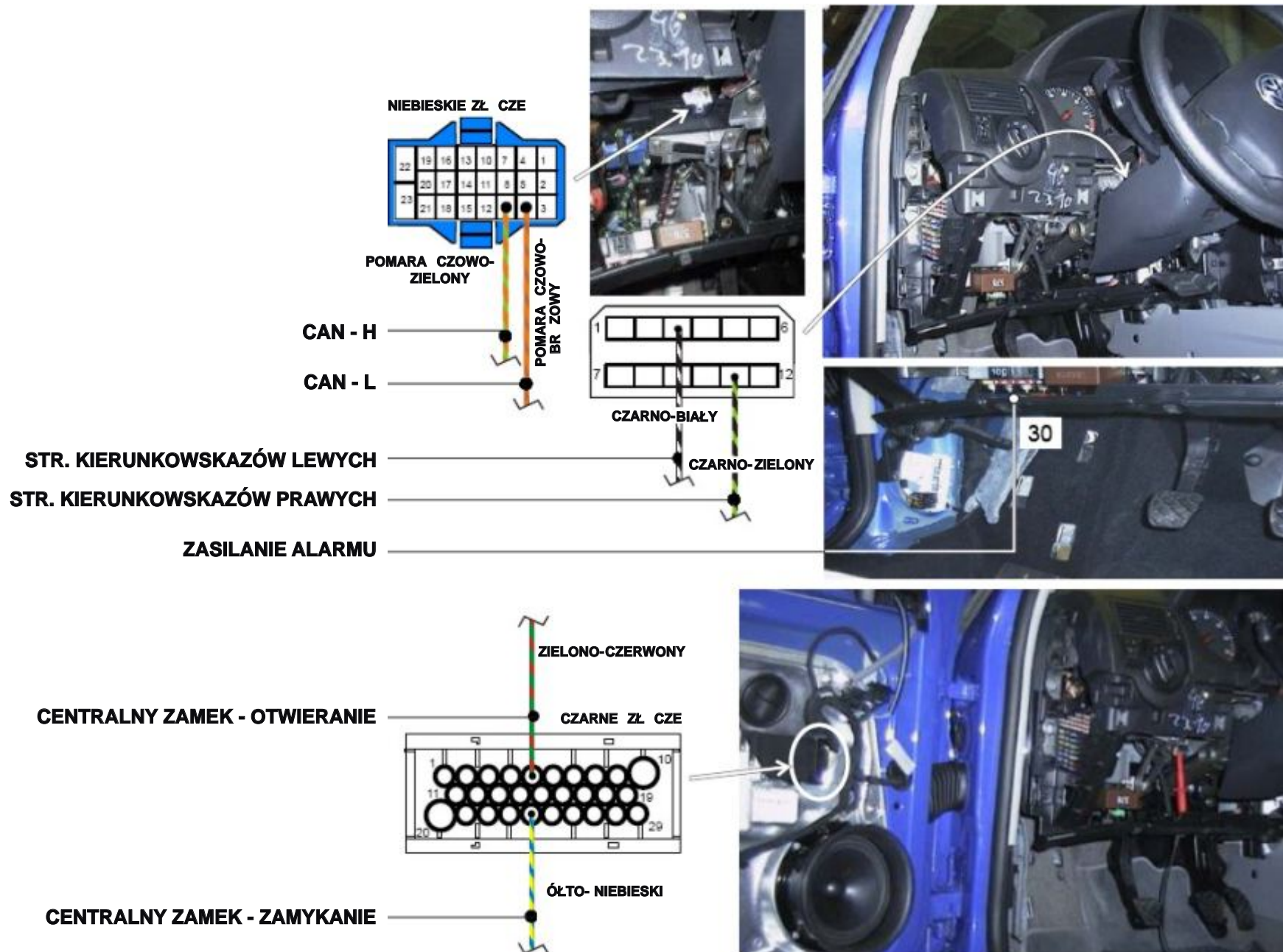

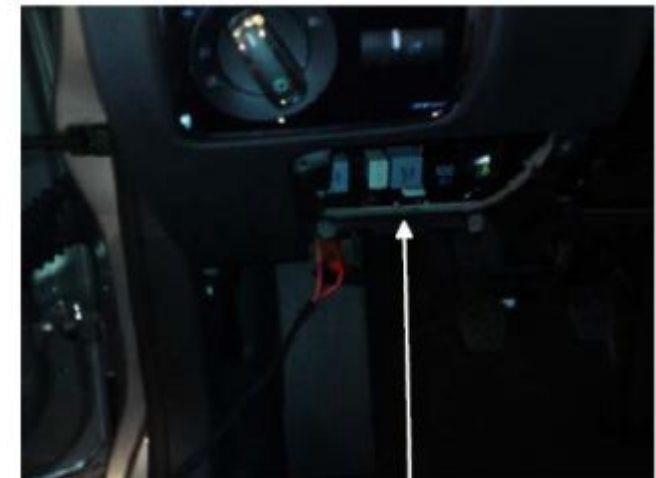

ZASILANIE ALARMU

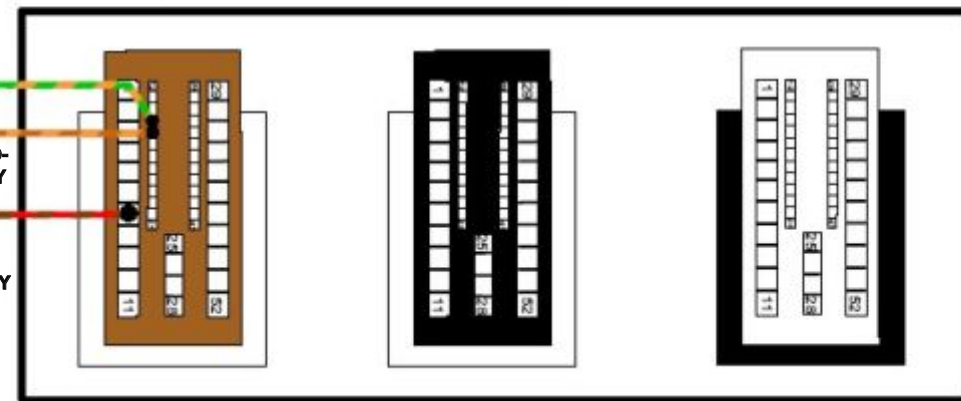
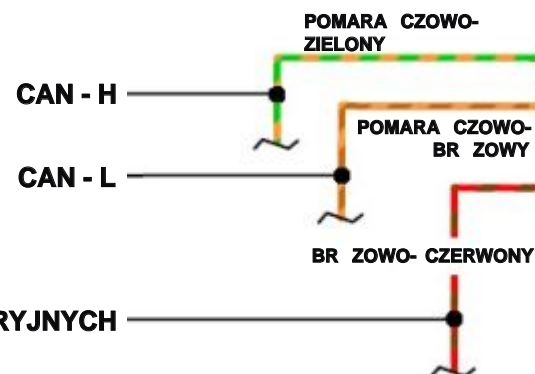



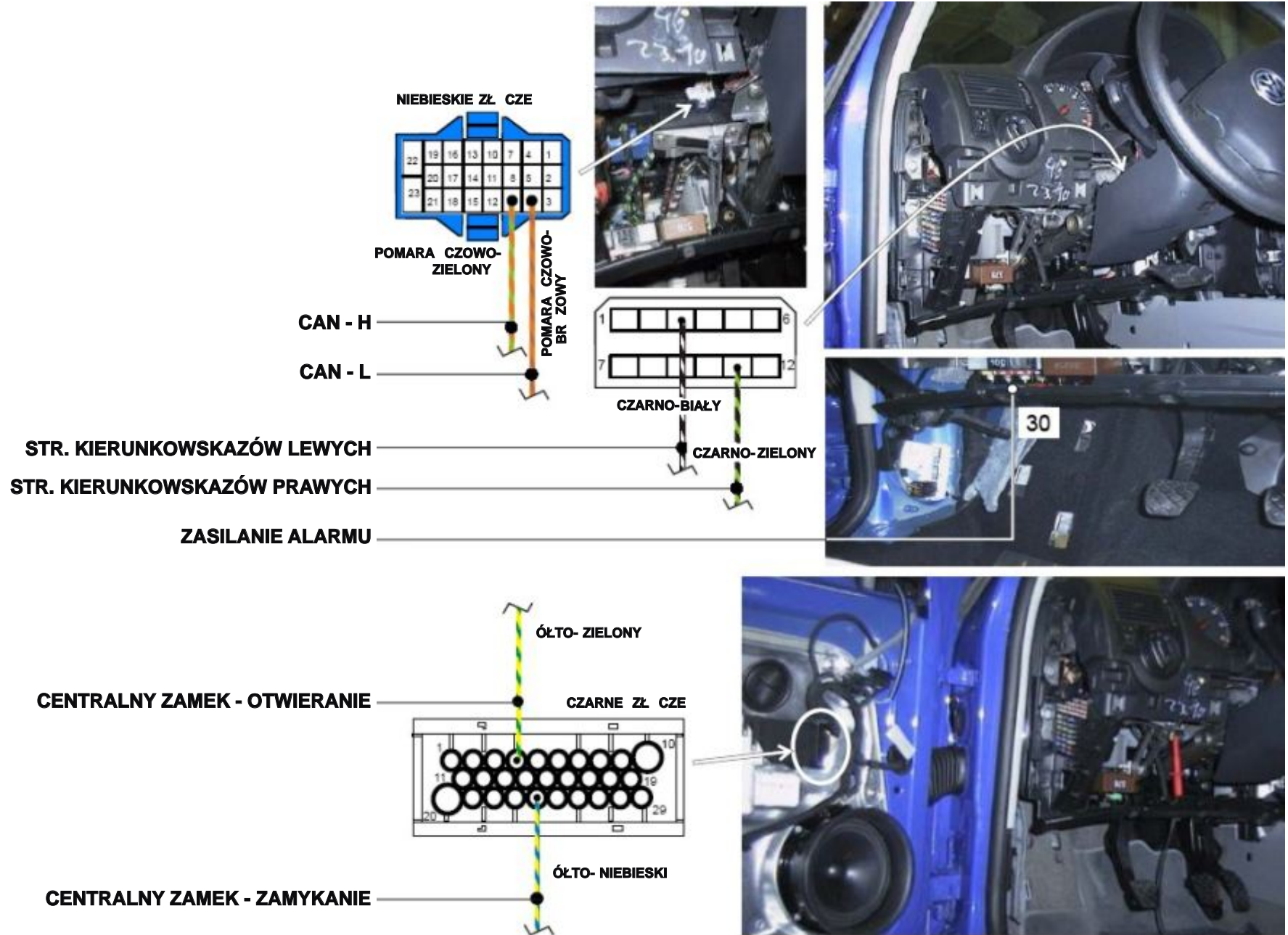



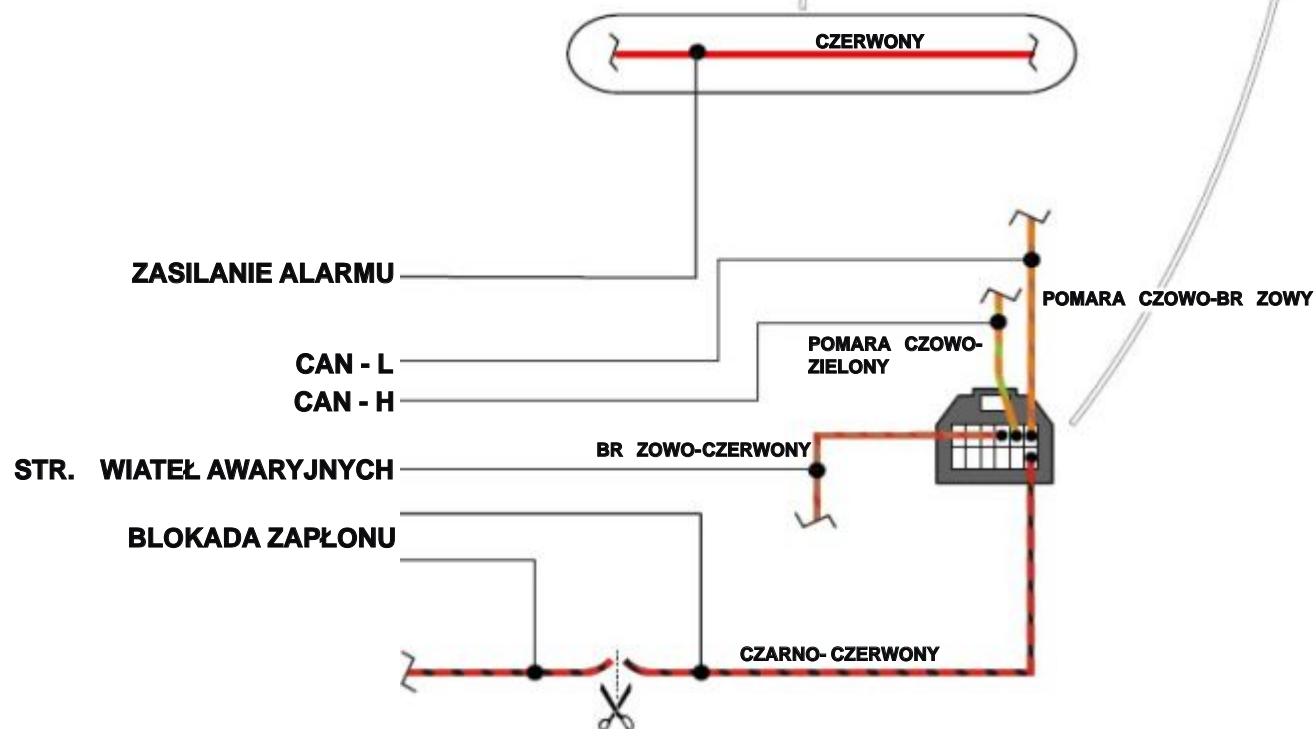

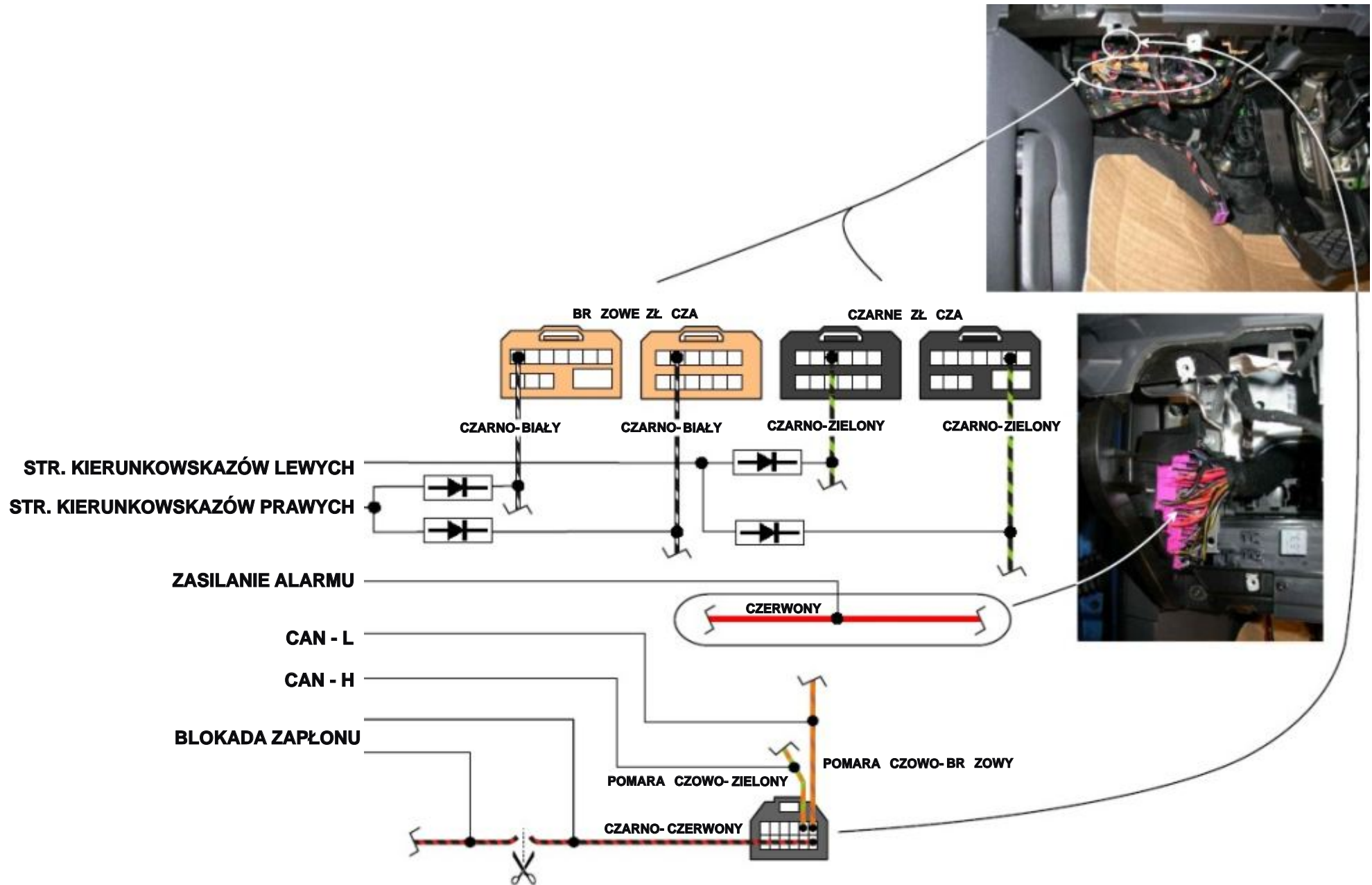

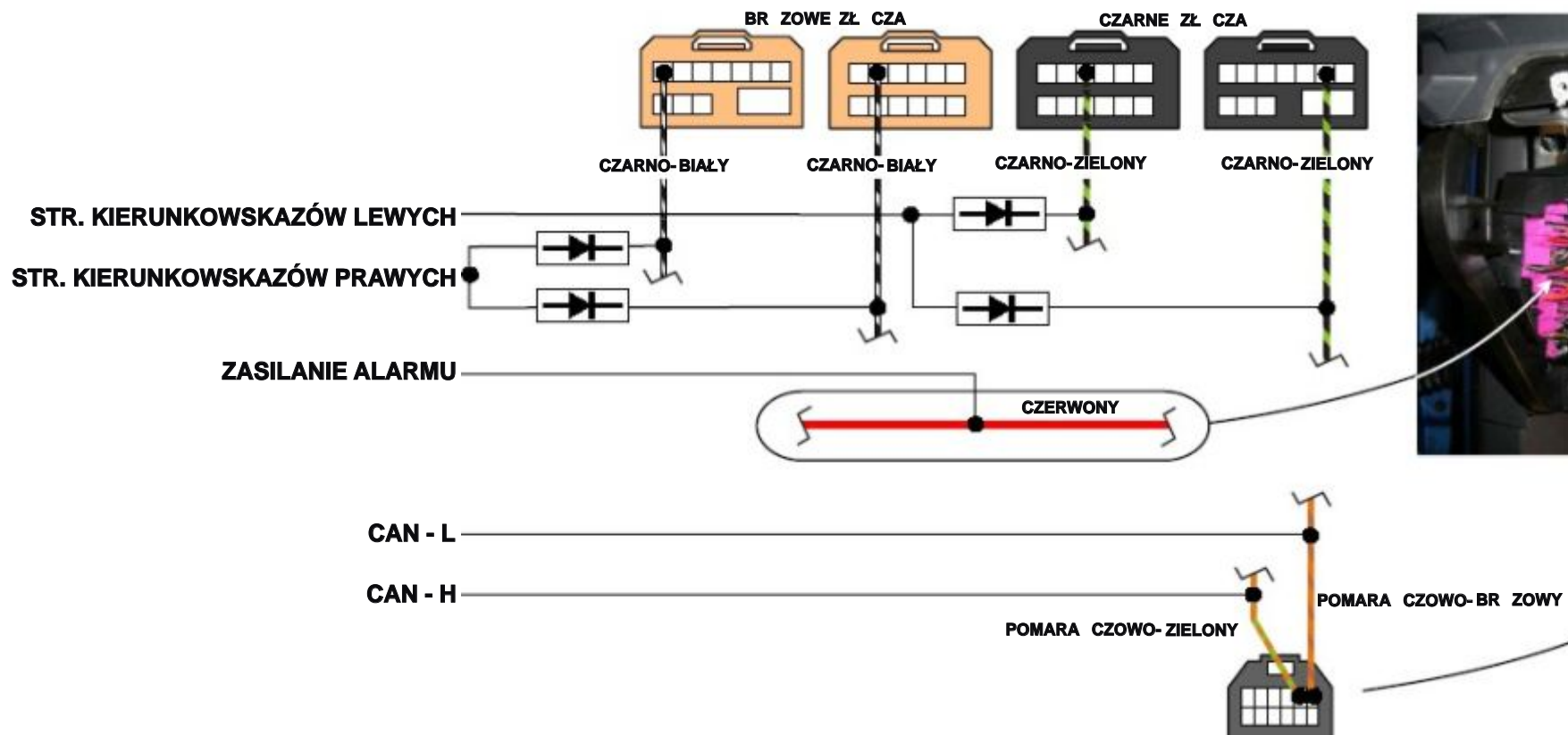

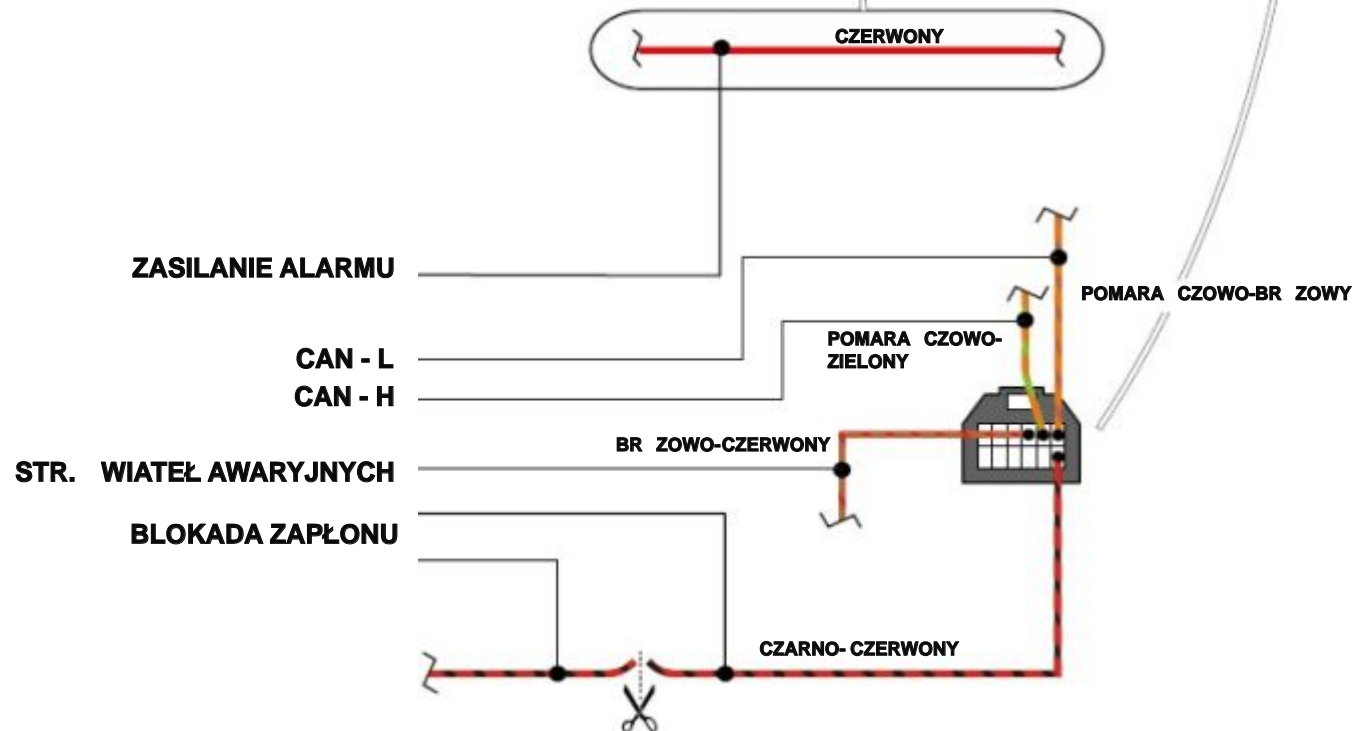



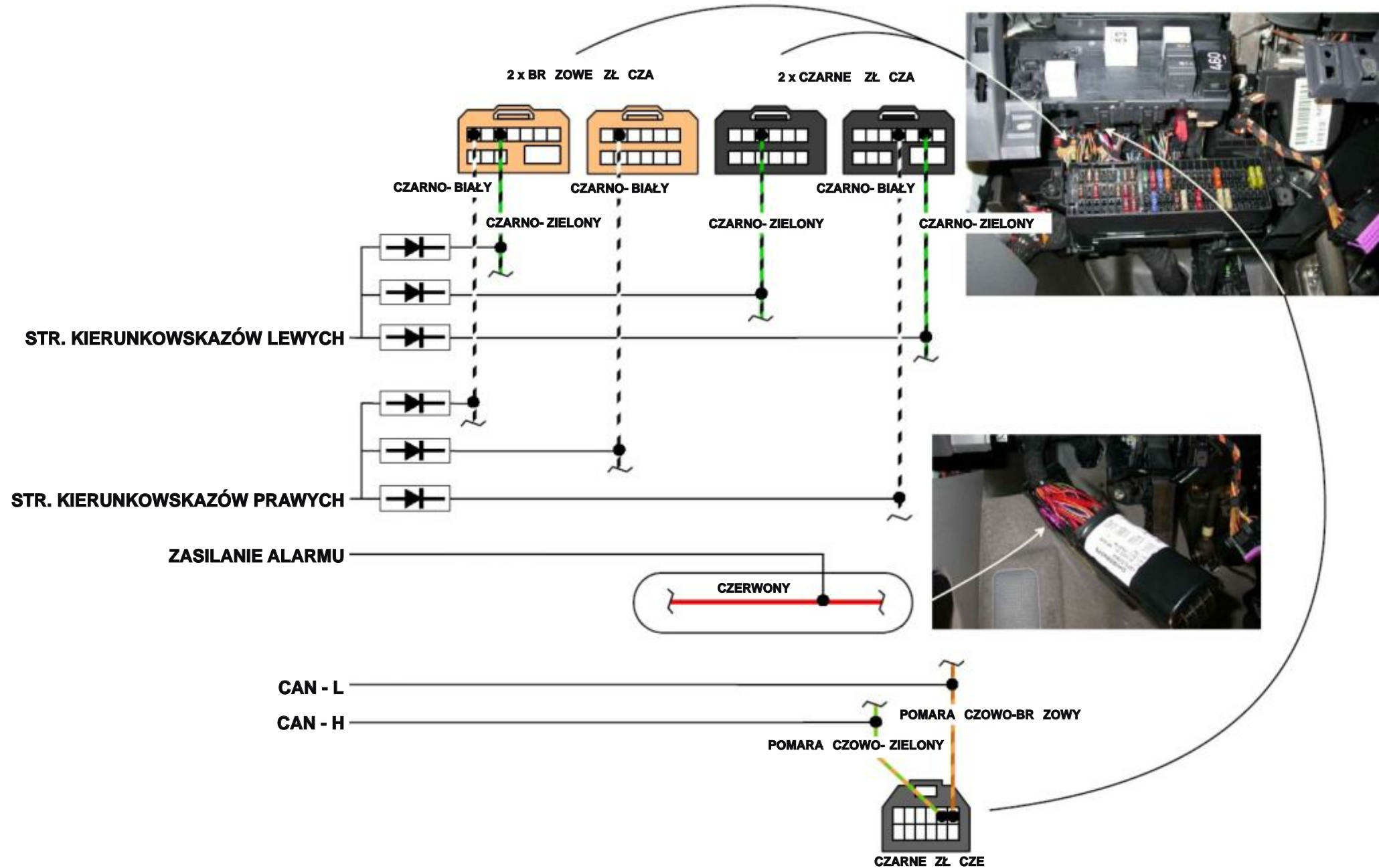

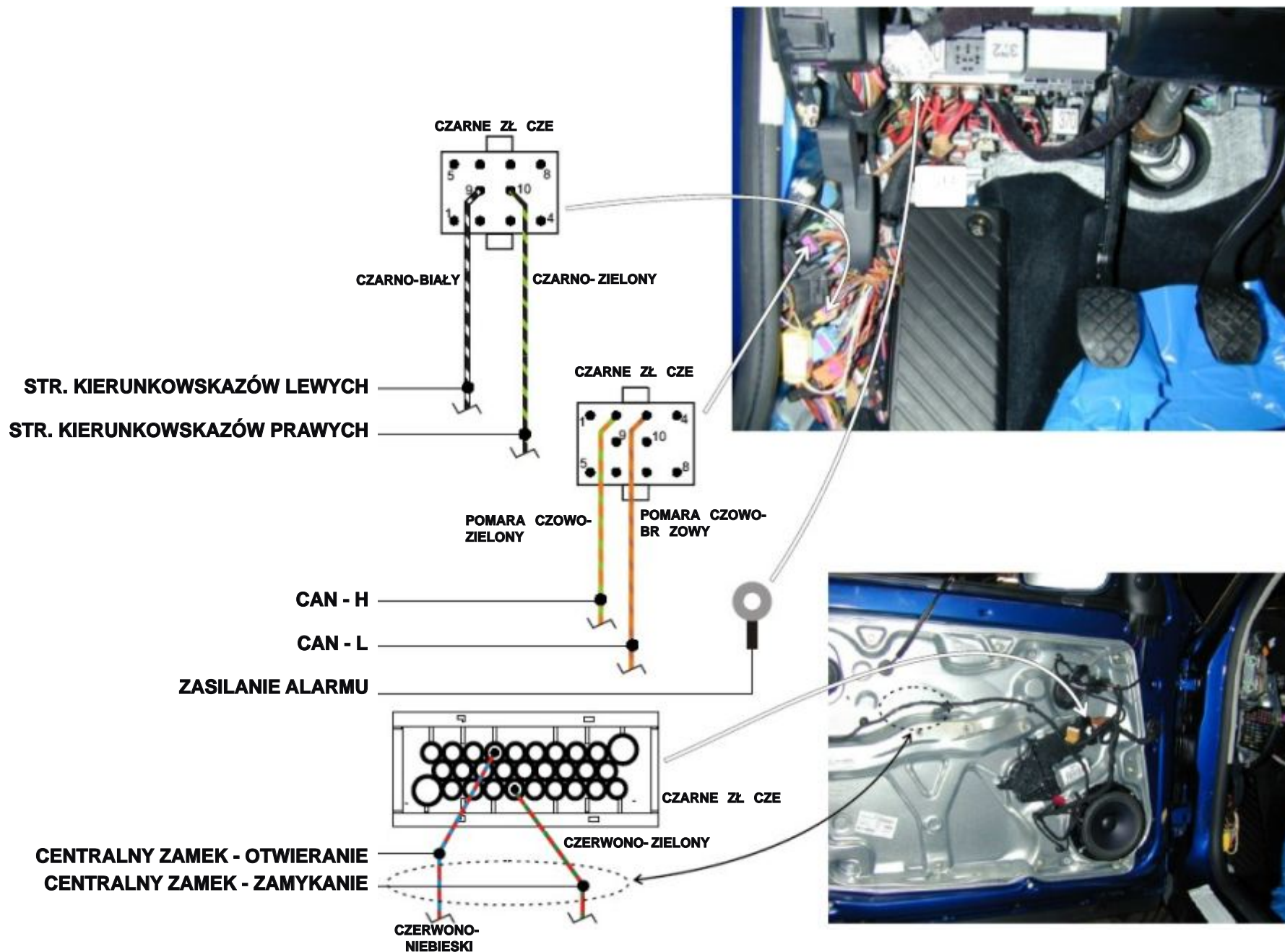

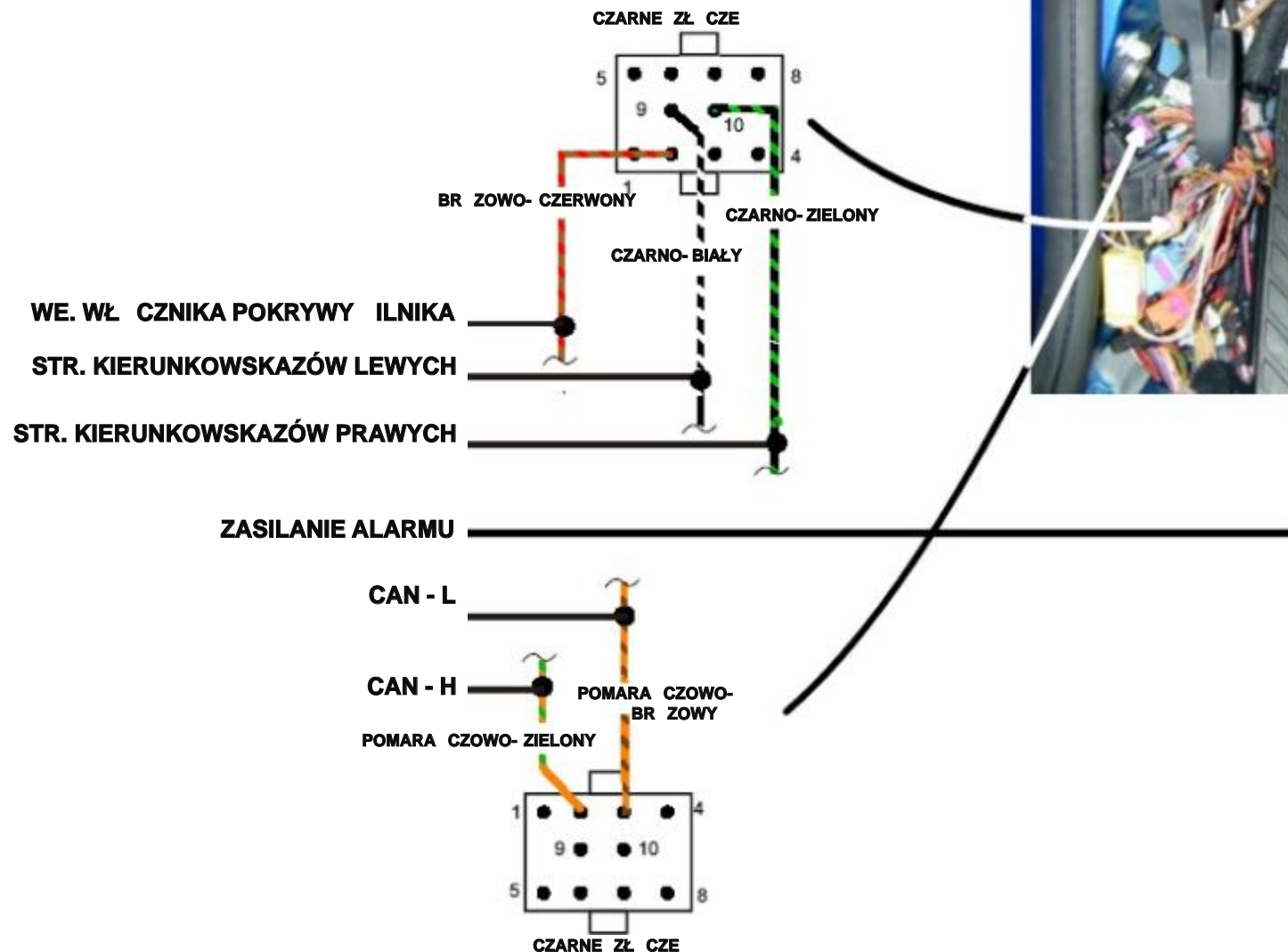



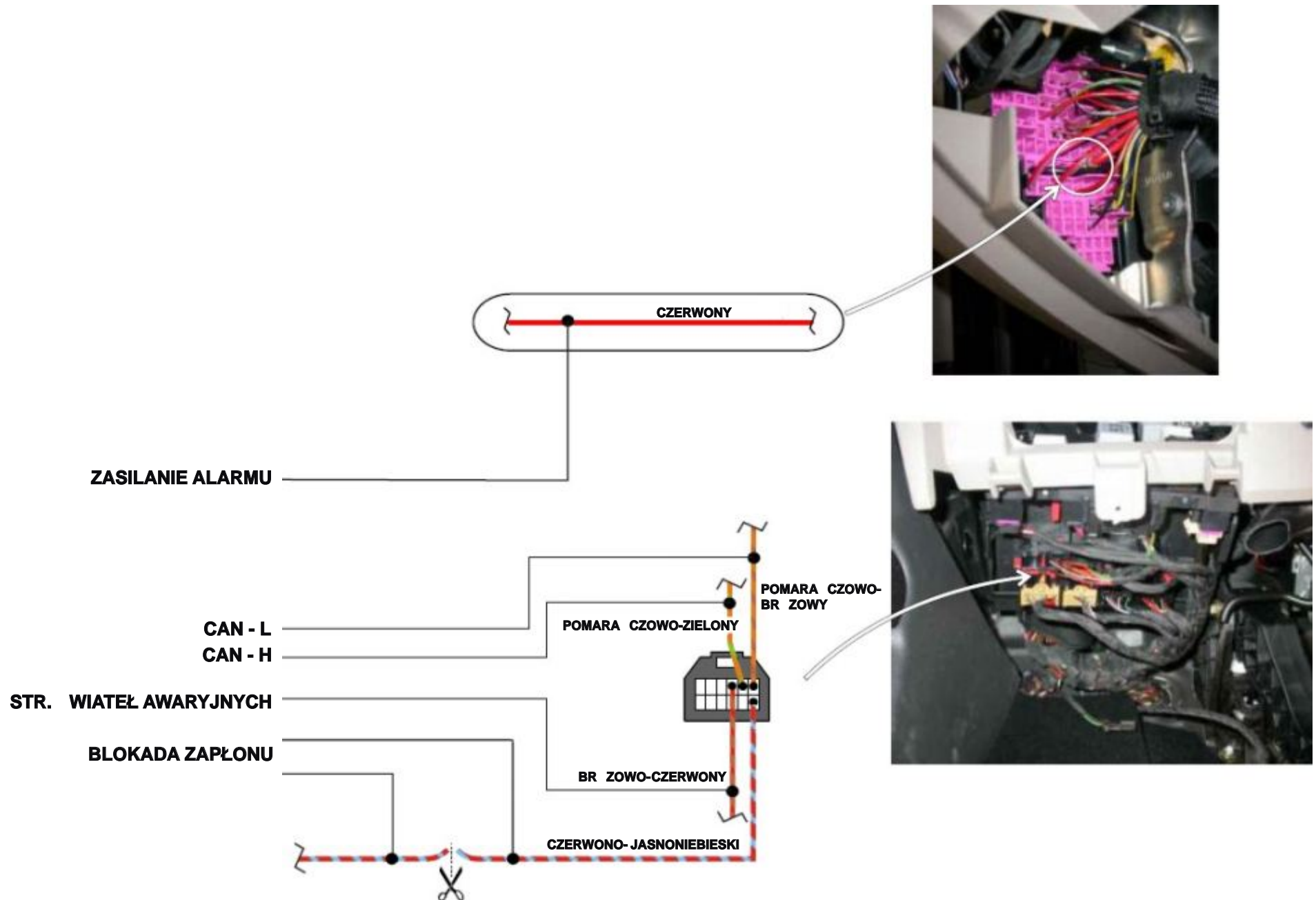



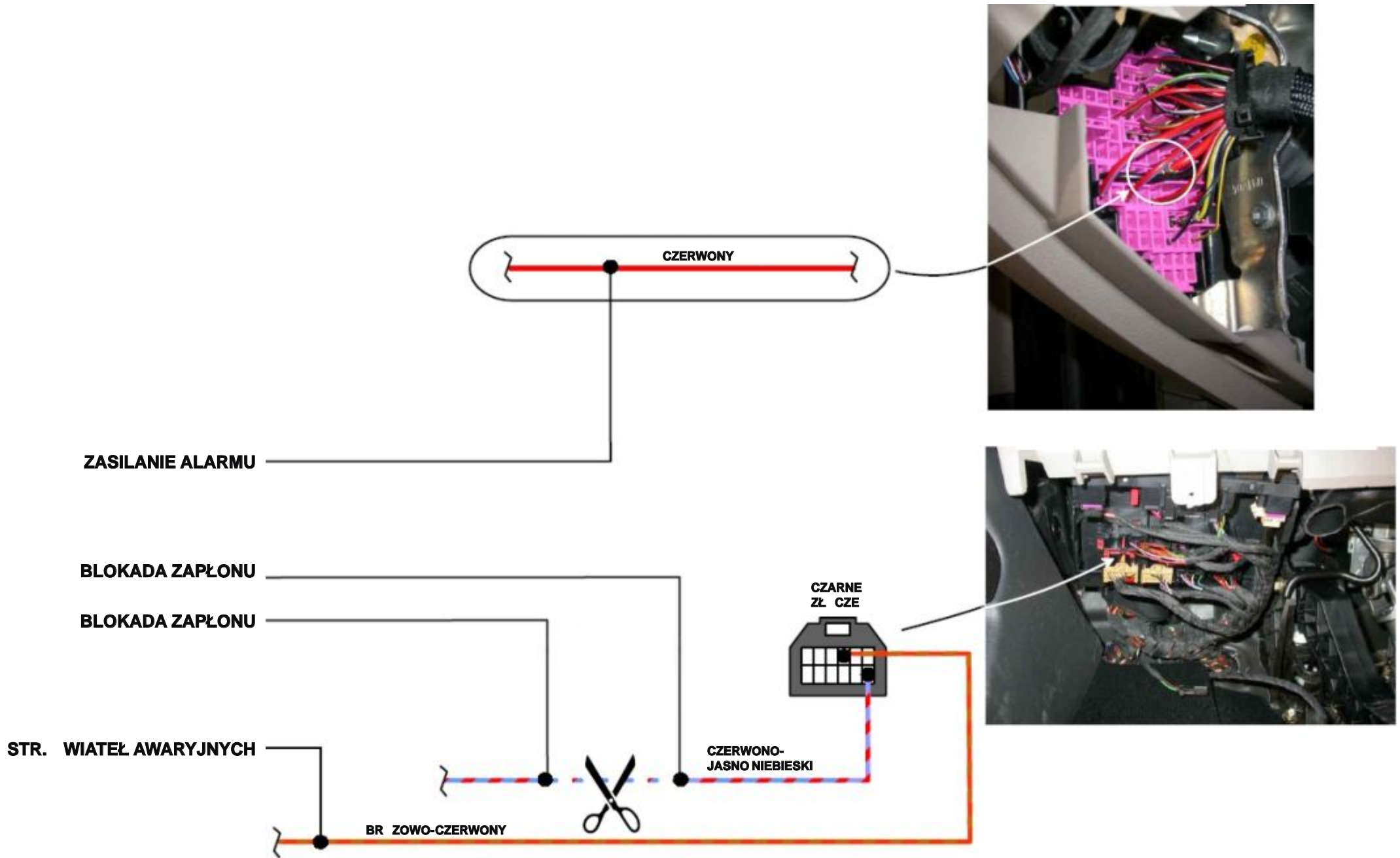

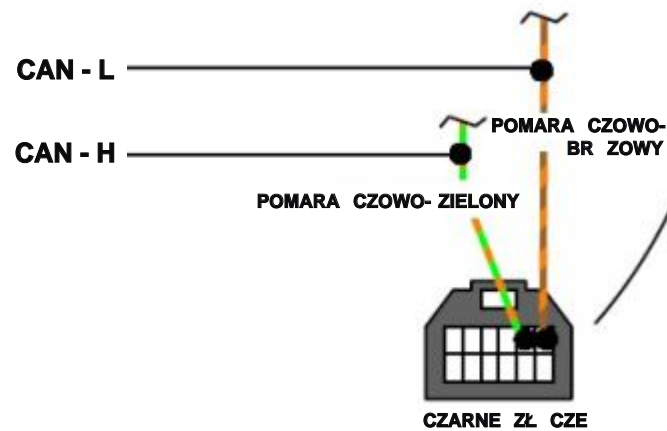

ZASILANIE ALARMU

STR. KIERUNKOWSKAZÓW LEWYCH

STR. KIERUNKOWSKAZÓW PRAWYCH

CAN - L

CAN - H

POMARA CZOWO-ZIELONY

CZARNO-ZIELONY

CZARNO-BIAŁY

Ⓒ

BR ZOWE  
ZŁ CZE

Ⓑ

CZARNE  
ZŁ CZE

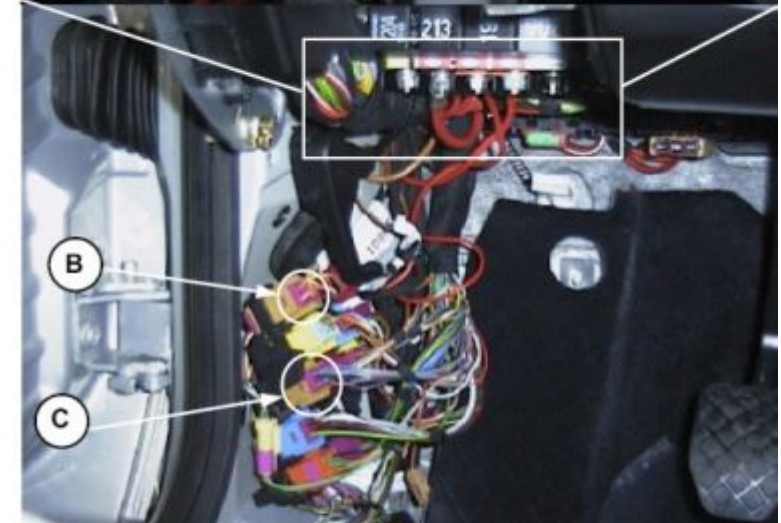
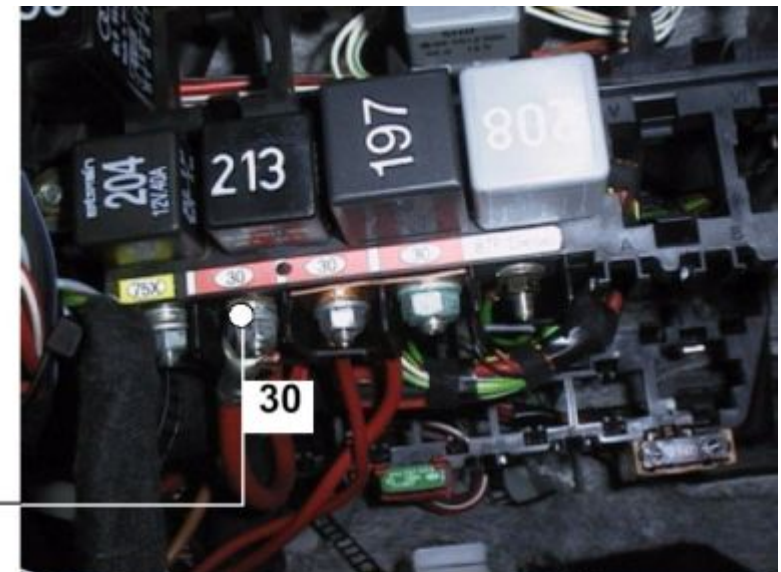
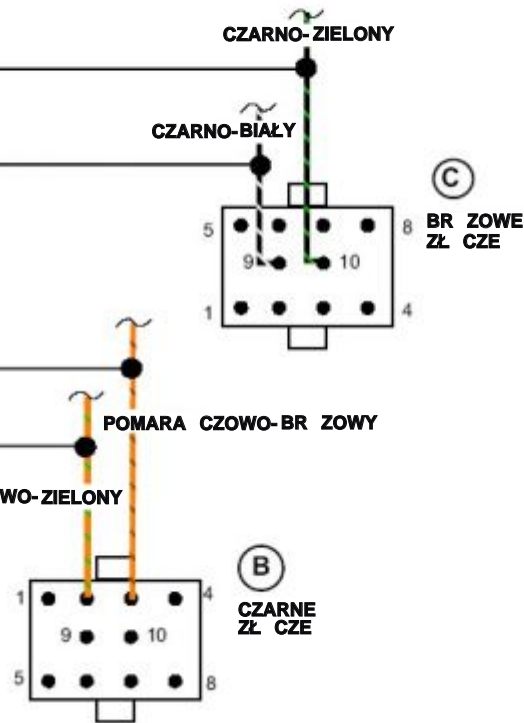

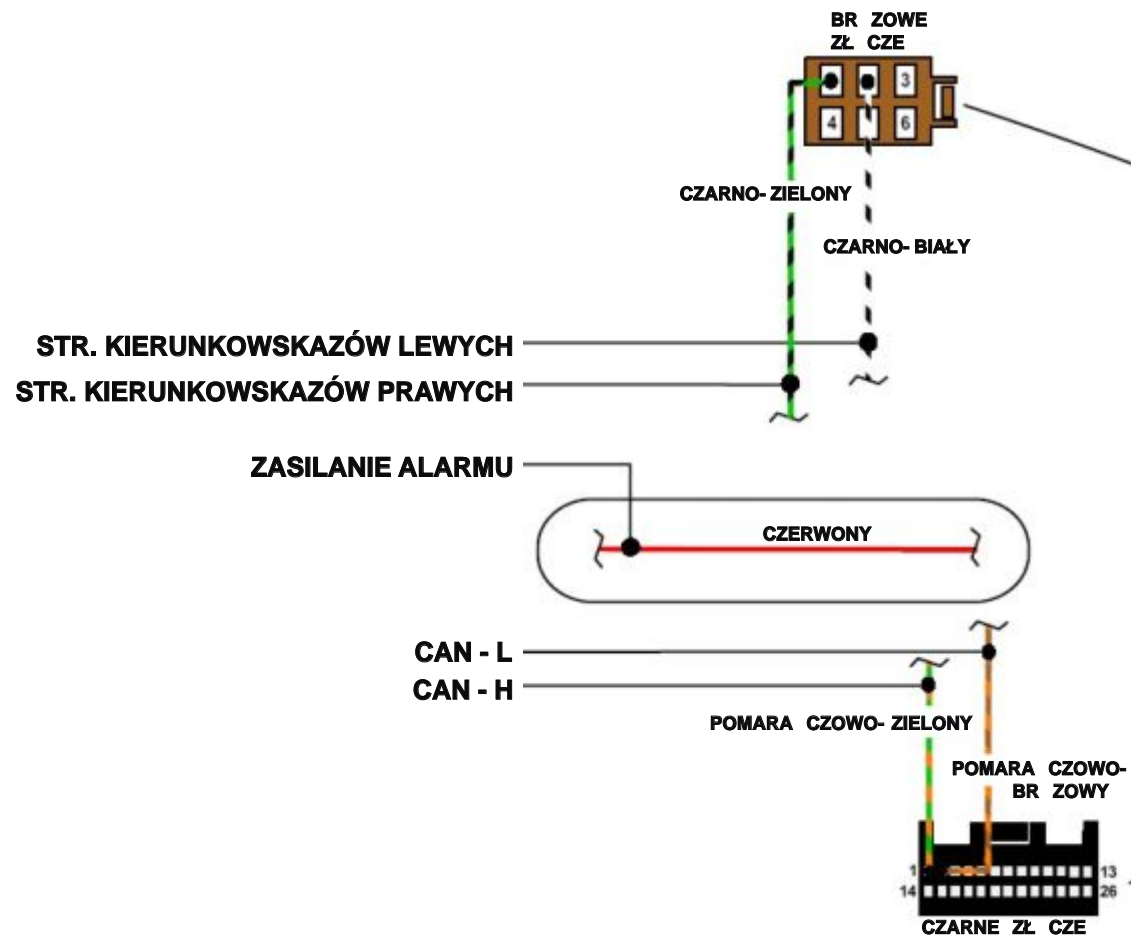



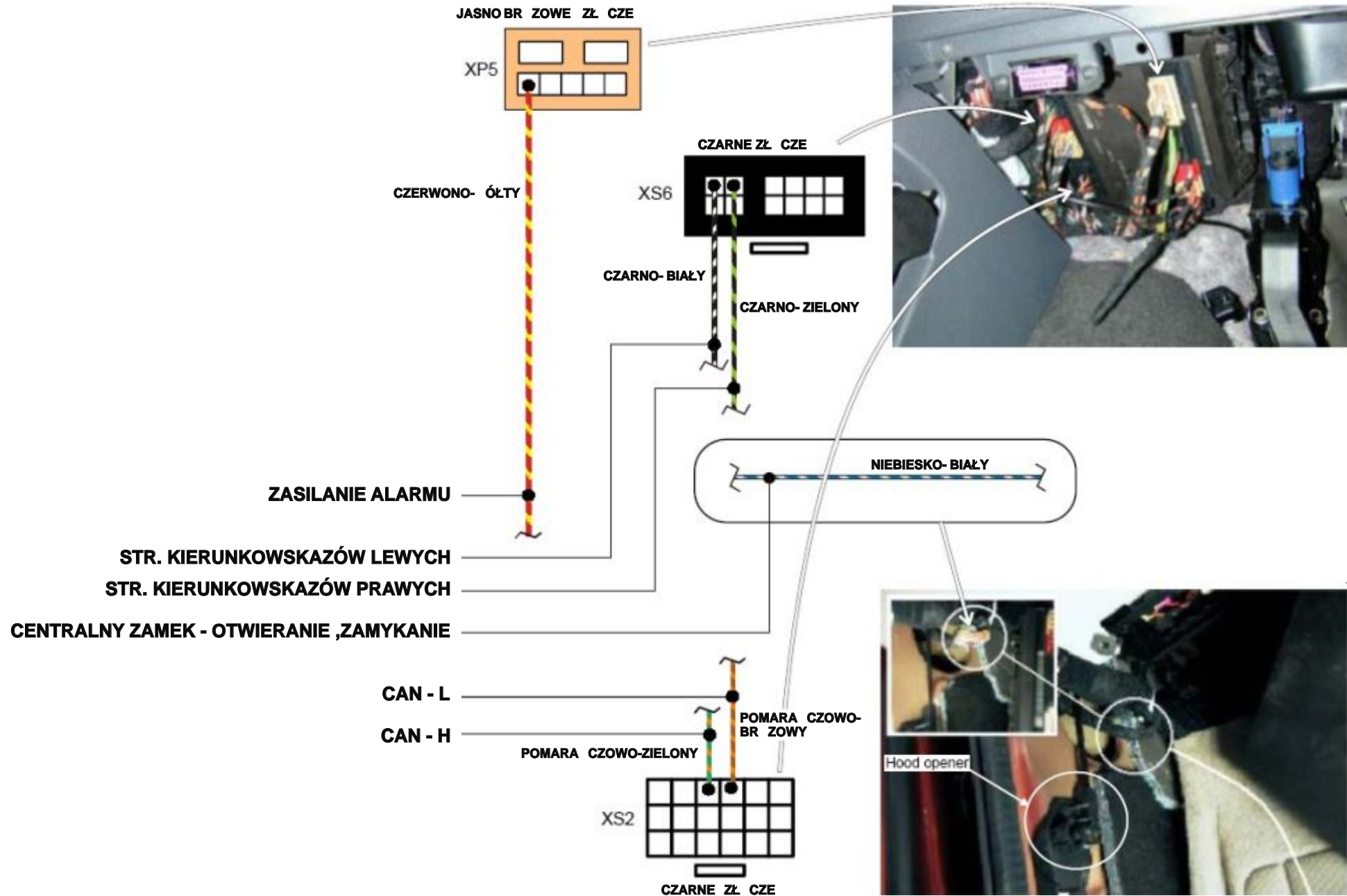

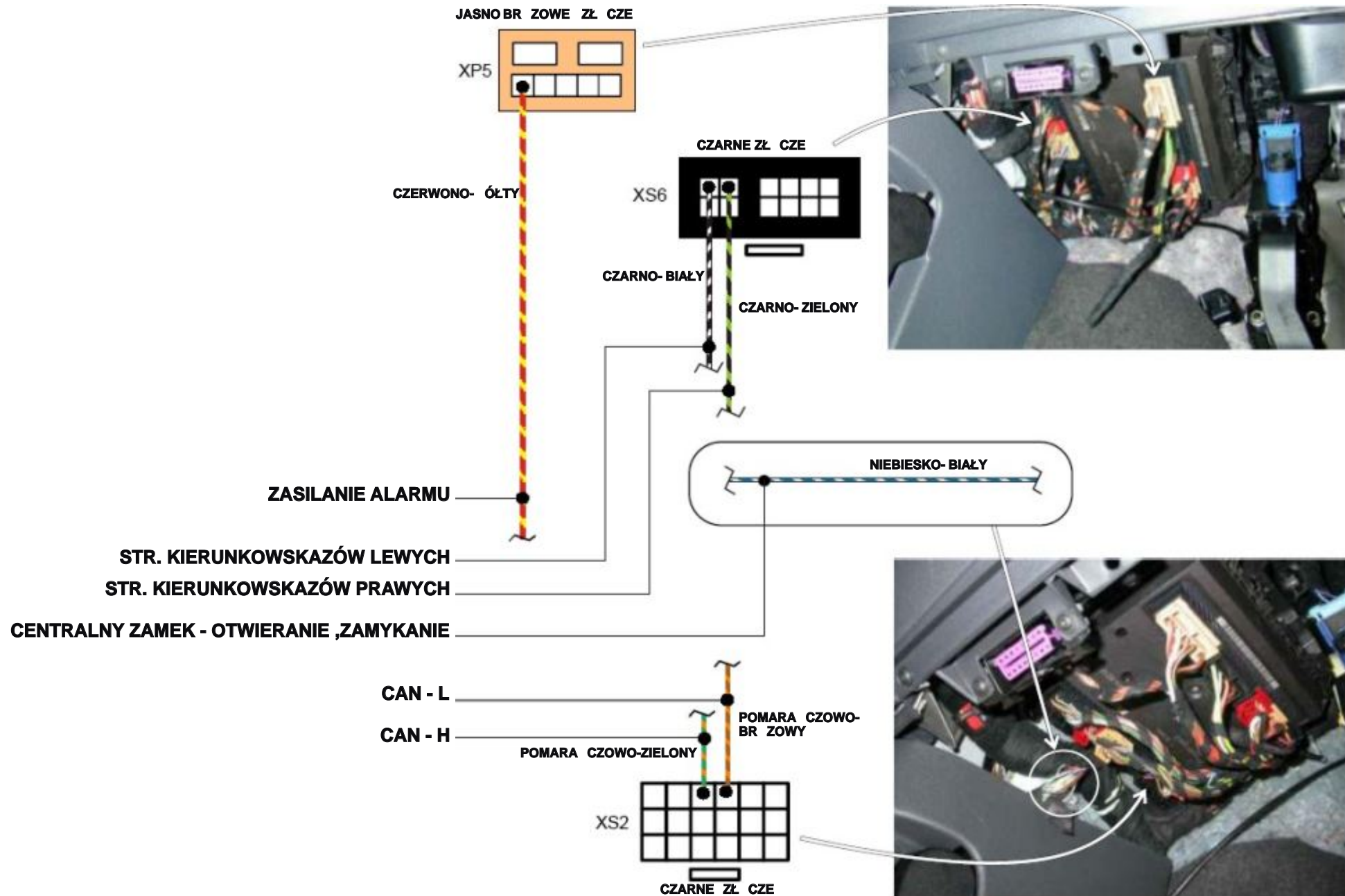

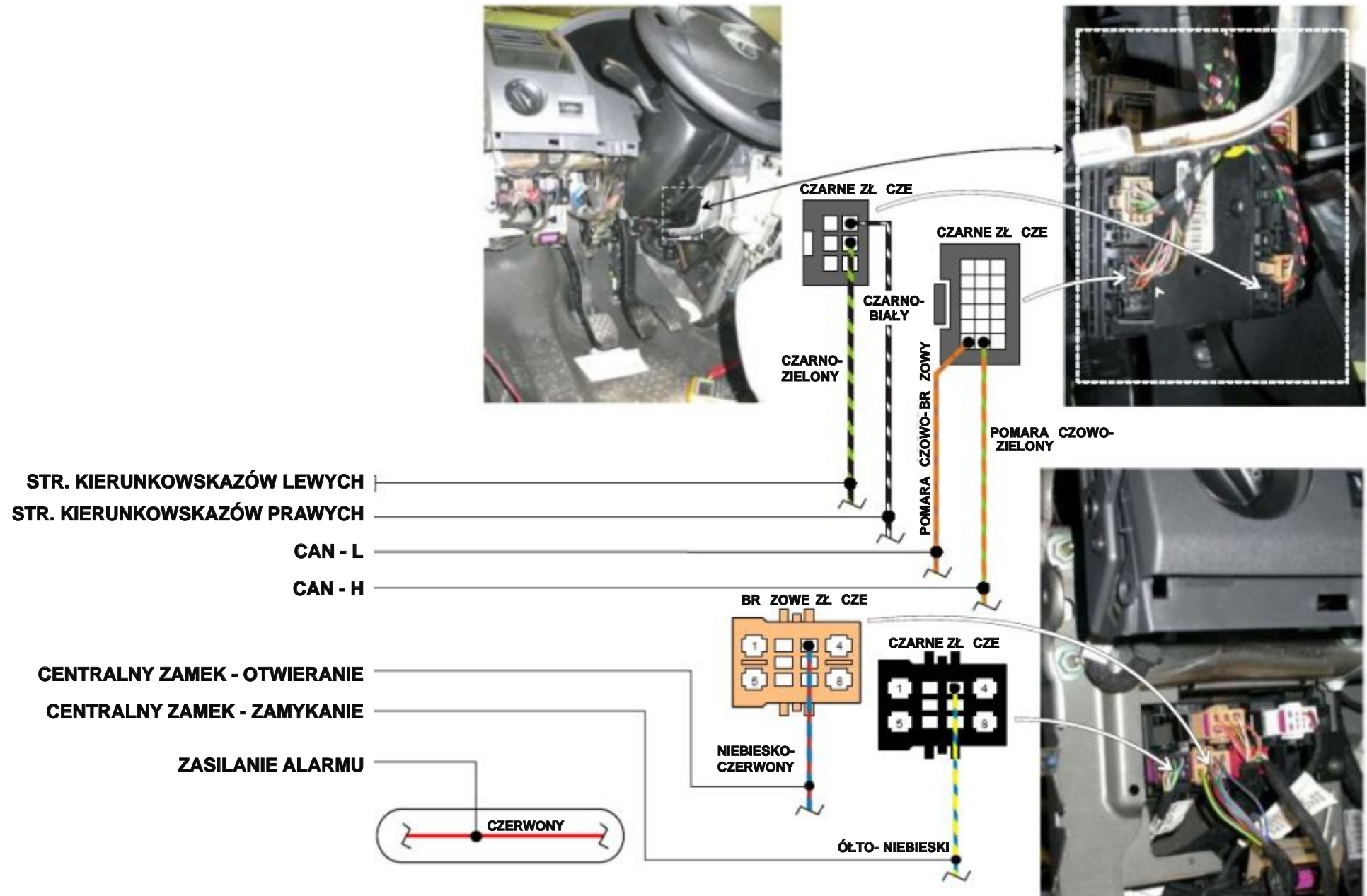





ZASILANIE ALARMU



CAN - L

CAN - H

STR. WIATEŁ AWARYJNYCH





