

NB! This installation diagram must only be used as a guideline for the installation. Equipment delivered with the car varies considerably from model to model and from market to market. Before starting the installation, be sure to check carefully the original diagram from the car manufacturer. DEFA A.S is not liable to compensate for possible damages that may occur due to faulty or insufficient installation manuals.

NOTE!!! HOW TO SYNCHRONIZE CAN INTERFACE:

- 1) INSERT 25A FUSE => LED WILL START FLICKERING
- 2) TURN ON IGNITION => LED WILL STOP FLICKERING WITHIN 30 SECONDS
THE ALARM IS NOW SYNCHRONIZED

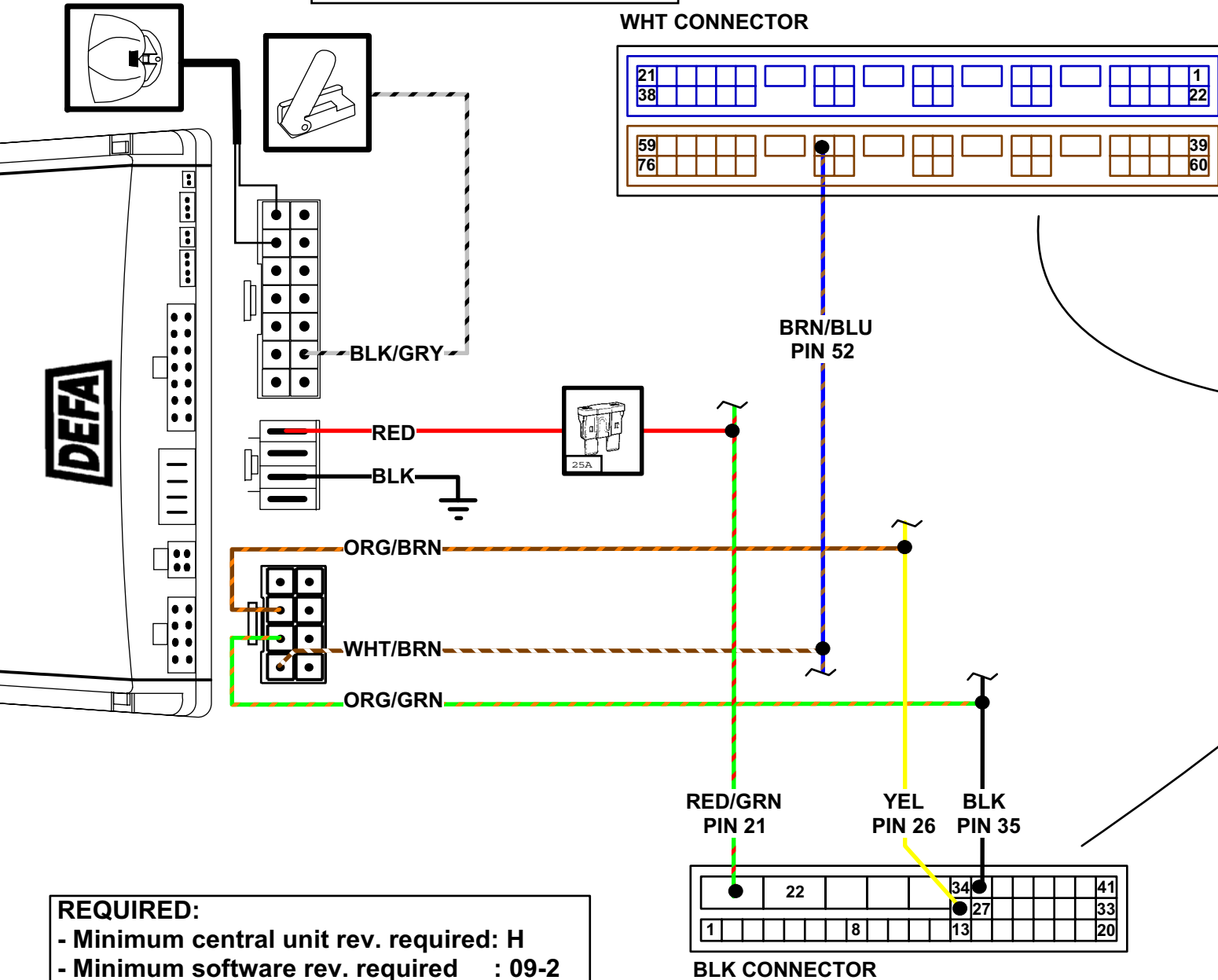

BLU CONNECTOR
BRN CONNECTOR



REQUIRED:

- Minimum central unit rev. required: H
- Minimum software rev. required : 09-2

Date : 2006.02.01
Rev : A
Page: 1 of 2

